

Liquid Silicone Rubber Cold Deck

Service Manual

Issue: v1.0 - November 2023

Document No.: 12534638

This product manual is intended to provide information for safe operation and/or maintenance. Husky reserves the right to make changes to products in an effort to continually improve the product features and/or performance. These changes may result in different and/or additional safety measures that are communicated to customers through bulletins as changes occur.

This document contains information which is the exclusive property of Husky Injection Molding Systems Limited. Except for any rights expressly granted by contract, no further publication or commercial use may be made of this document, in whole or in part, without the prior written permission of Husky Injection Molding Systems Limited.

Notwithstanding the foregoing, Husky Injection Molding Systems Limited grants permission to its customers to reproduce this document for limited internal use only.

Husky[®] product or service names or logos referenced in these materials are trademarks of Husky Injection Molding Systems Ltd. and may be used by certain of its affiliated companies under license.

All third-party trademarks are the property of the respective third-party and may be protected by applicable copyright, trademark or other intellectual property laws and treaties. Each such third-party expressly reserves all rights into such intellectual property.

©2023 Husky Injection Molding Ltd. All rights reserved.

General Information

Telephone Support Numbers

North America	Toll free	1-800-465-HUSKY (4875)
	Direct	437-781-8572
Europe	EC (most countries)	008000 800 4300
	Direct and Non-EC	+ 352 2786 7967
Asia	Toll Free	400 021 0557
	Direct:	+86 21 6146 9058
	Japan Toll Free	0120988896
	Japan Direct	+03 6316 2444
Latin America	Brazil Toll Free	+55 11 4589-7200
	Brazil Direct	+55 11 3181-0607
	Mexico Toll Free	+52 80 0024-0580
	Mexico and Latin America Direct	+52 55 9085 3008

For on-site service, contact your nearest Husky Regional Service and Sales office.

For non-emergency questions and issues you may also e-mail Husky at techsupport@husky.ca.

Husky Regional Service and Sales Offices

For the location closest to you, please visit www.husky.co.

Product Upgrades

Upgrades are available that can improve your output, reduce cycle times, and add functionality to your Husky equipment.

To see what upgrades are available for your Husky equipment, visit our website at www.husky.co or call your nearest Husky Regional Service and Sales Office.

Ordering Spare Parts

All spare parts for Husky equipment can be ordered through your nearest Husky Parts Distribution Center or online at www.husky.co.

LSR Cold Deck Refurbishing

Husky offers services for repairing, modifying, and retrofitting Husky cold decks. Contact your Husky Regional Service and Sales office for details.

Table of Contents

General Information.....	iii
Telephone Support Numbers.....	iii
Husky Regional Service and Sales Offices.....	iii
Product Upgrades.....	iii
Ordering Spare Parts.....	iv
LSR Cold Deck Refurbishing.....	iv
Chapter 1: Introduction.....	9
1.1 Purpose of the Equipment.....	9
1.2 Restrictions of Use.....	9
1.3 Unauthorized Modifications.....	9
1.4 Auxiliary Equipment.....	10
1.5 Nameplates.....	10
1.5.1 Cold Deck Nameplate.....	10
1.6 Documentation.....	11
1.6.1 Manuals.....	11
1.7 Engineering Drawings and Schematics.....	12
1.8 Safety Alert Conventions.....	12
1.9 Training.....	13
1.10 Special Tools.....	14
1.10.1 Valve Stem Removal Tools.....	14
1.10.2 Backup Pad Removal Tools.....	14
1.10.3 Double Delta Seal Installation Tools.....	14
1.10.4 Thermocouple Wire Stripping Tools.....	15
1.10.5 Crimping Tools for Contact Pins (25 or 64 Pin Connectors).....	15
Chapter 2: Safety Summary.....	17
2.1 Qualified Personnel.....	17
2.2 Safety Guidelines.....	17
2.3 Safety Hazards.....	17
2.3.1 Mechanical Hazards.....	18
2.3.2 Burn Hazards.....	18
2.3.3 Electrical Hazards.....	19
2.3.4 Gas, Vapor and Dust Emissions.....	19
2.3.5 Slip, Trip or Fall Hazards.....	19
2.3.6 Lifting Hazards.....	19
2.3.7 Pneumatic Hazards.....	19
2.4 Safety Signs.....	20
2.5 Lockout and Tagout.....	22
2.6 Personal Protective Equipment and Safety Equipment.....	22
2.6.1 Personal Protective Equipment (PPE).....	22
2.6.2 Safety Equipment.....	23
2.7 Material Safety Data Sheet (MSDS).....	24

2.8	Materials, Parts and Processing.....	24
2.9	Safety Latch Bars.....	25
2.10	Lift Bars and Swivel Hoist Rings.....	25
Chapter 3: Specifications.....		27
3.1	Weight.....	27
3.2	Operating Temperature.....	27
3.3	Electrical Specifications.....	27
3.3.1	Controller Requirements.....	27
3.3.2	Manifold Temperature Control.....	28
3.3.2.1	Thermocouple Wires.....	28
3.4	Pneumatic Specifications.....	28
3.5	Recommended Lubricants.....	29
3.6	Rust Inhibitor Specifications.....	30
3.7	Torque Specifications.....	30
Chapter 4: Installation and Removal.....		33
4.1	Lifting and Handling.....	33
4.1.1	Lifting and Handling Using a Single Lifting Point.....	34
4.1.1.1	Laying Down Plates Using a Single Lifting Point.....	34
4.1.1.2	Picking Up Plates Using a Single Lifting Point.....	35
4.1.2	Lifting and Handling Using Multiple Lifting Points.....	36
4.1.3	Lifting Using a Lift Bar.....	37
4.1.4	Lifting Using Swivel Hoist Rings.....	38
4.2	Mounting Methods.....	39
4.2.1	Direct Bolting.....	39
4.2.2	Clamping.....	40
4.2.3	Quick Mold Changers and Clamping Systems.....	41
4.3	Removing and Installing the Cold Deck.....	41
4.3.1	Installing the Cold Deck.....	41
4.3.2	Removing the Cold Deck.....	43
Chapter 5: Startup and Operation.....		45
5.1	Preparing the Cold Deck.....	45
5.2	Bringing the Cold Deck, Mold and Machine to Operating Temperatures.....	46
5.3	Precharging the Cold Deck.....	46
5.4	Producing Test Parts.....	47
Chapter 6: Maintenance.....		49
6.1	Scheduled and Non-Scheduled Maintenance.....	49
6.1.1	Preventive Maintenance.....	50
6.1.2	Service Procedures.....	50
6.2	Changing the Liquid Silicone Rubber Color.....	51
6.3	Measuring Preload.....	51
6.3.1	Measuring Preload for Manifolds in VG-LX and EX Systems.....	52
6.4	Removing and Installing the Cavity Plate.....	52
6.4.1	Removing the Cavity Plate On a Work Bench.....	53

6.4.2	Installing the Cavity Plate on a Work Bench.....	53
6.4.3	Removing the Cavity Plate in the Machine.....	55
6.4.4	Installing the Cavity Plate in the Machine.....	56
6.5	Removing and Installing the Backing Plate.....	57
6.5.1	Removing the Backing Plate.....	57
6.5.2	Installing the Backing Plate.....	59
6.6	Removing and Installing Manifolds.....	61
6.6.1	Removing a Manifold.....	61
6.6.2	Inspecting and Cleaning Manifolds.....	63
6.6.3	Installing a Manifold.....	64
6.7	Removing and Installing Backup Pads.....	66
6.7.1	Removing the Backup Pads.....	66
6.7.2	Installing the Backup Pads.....	67
6.8	Removing and Installing Valve Stems.....	68
6.8.1	Removing the Valve Stems.....	68
6.8.2	Installing the Valve Stems.....	71
6.9	Replacing the Double Delta Seals.....	72
6.10	Removing and Installing Nozzle Tips.....	74
6.10.1	Removing the Nozzle Tips.....	74
6.10.2	Installing the Nozzle Tips.....	75
6.10.3	Troubleshooting Nozzle Tip Heights.....	77
6.11	Removing and Installing Nozzle Housings.....	77
6.11.1	Removing Nozzle Housings.....	77
6.11.2	Inspecting and Cleaning Nozzle Housings.....	78
6.11.3	Installing the Nozzle Housings.....	78
6.12	Removing and Installing Manifold Bushings.....	80
6.12.1	Removing Liquid Silicone Rubber Manifold Bushings.....	80
6.12.2	Installing Liquid Silicone Rubber Manifold Bushings.....	81
6.12.3	Installing Bushing Insert Set Screw into the Liquid Silicone Rubber Manifold Bushings...	81
6.13	Removing and Installing the Sprue Bushing.....	81
6.13.1	Removing the Sprue Bushing.....	81
6.13.2	Installing the Sprue Bushing.....	82
6.14	Removing Air and Water Plugs.....	84
6.15	Removing Liquid Silicone Rubber from the Cold Deck.....	85
6.15.1	Plate Cleaning and Inspection.....	85
6.16	Removing Liquid Silicone Rubber from the Manifold Plate.....	87
Chapter 7: Storage and Shipping.....		89
7.1	Corrosion Protection.....	89
7.2	Short Term Storage.....	89
7.2.1	Storing in the Machine.....	90
7.2.2	Storing Outside the Machine.....	90
7.3	Long Term Storage.....	91
7.4	Shipping the Cold Deck.....	91

Chapter 1 Introduction

This chapter provides general information about the cold deck assembly, available equipment manuals, and training opportunities



IMPORTANT!

This manual is intended for cold deck operators and assumes the cold deck has been properly installed.

1.1 Purpose of the Equipment

Husky equipment and systems are designed for injection molding applications only, using approved materials and operating within design guidelines.

Contact your nearest Husky Regional Service and Sales office if you plan to use a Husky product for anything other than its intended use.

1.2 Restrictions of Use

Husky injection molding equipment must never be:

- operated by more than one person
- used for any purpose other than that described in [Section 1.1](#), unless otherwise approved by Husky
- used to extrude any materials not outlined in the scope of the harmonized EN201 or ANSI B151.1 standard
- operated or serviced by personnel unfamiliar with the inherent risks and necessary precautions related to injection molding equipment
- operated at temperatures higher than the maximum permissible temperature for the resin

1.3 Unauthorized Modifications

Unauthorized modifications or reconstruction of any Husky injection molding system is strictly prohibited. Modifications can be unsafe and/or void warranty.

Contact your nearest Husky Regional Service and Sales office to discuss modifications or requirements for Husky systems.

1.4 Auxiliary Equipment

Husky is only responsible for the interaction of Husky equipment and systems with auxiliary equipment when Husky is the system integrator. If auxiliary equipment is removed, the user must install proper safeguards to prevent access to the hazards.

For information about integrating non-Husky auxiliary equipment, contact your nearest Husky Regional Service and Sales office.

1.5 Nameplates

Nameplates are affixed to the operator's side of the cold deck for quick identification of the equipment type, source and general specifications.

**IMPORTANT!**

The cold deck nameplates must never be removed. The information on the nameplates is necessary for mold selection, parts ordering and troubleshooting.

Immediately order a new nameplate for the cold deck if it is missing or damaged.

1.5.1 Cold Deck Nameplate

Every cold deck nameplate lists the following information:

- the location where the cold deck was manufactured
- the project number
- the material type allowed to be used in the cold deck
- the melt and mold temperatures
- electrical requirements and specifications

NOTE:

Other details and specifications may be required.

**IMPORTANT!**

Each cold deck is designed to process a specific type and grade of liquid silicone rubber (LSR) based on the customer's requirements. Use of any other type or grade of LSR could affect part quality and/or the performance of the cold deck. Before using a different type or grade of LSR, contact Husky.

CAUTION!

Mechanical hazard – risk of damage to the cold deck. Never operate the cold deck outside of the temperature ranges indicated on the nameplate. Internal resin leakage or component damage could occur.

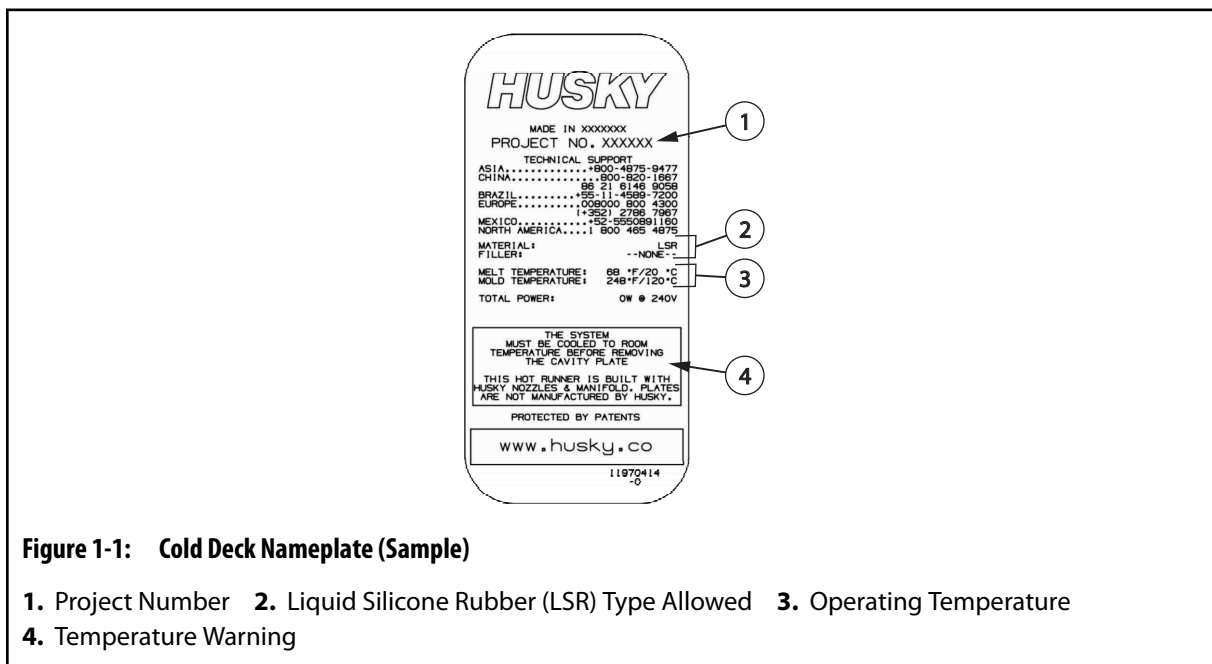

1.6 Documentation

A full set of manuals, drawings, schematics, certificates and other documentation are available for every Husky cold deck.

The following describes the documentation provided with each system, along with common conventions all readers should be familiar with.

**IMPORTANT!**

Keep all manuals in a convenient location for future reference.

1.6.1 Manuals

Husky manuals aid in the safe and proper use of Husky products. Where applicable, the manuals provide instructions on installation, operation and maintenance

Personnel should thoroughly review all manuals provided with their Husky equipment prior to performing any tasks. Proceed with tasks only if all instructions are understood and always follow applicable workplace safety requirements.



IMPORTANT!

Images in the manuals are for reference only and may not represent specific equipment details. Refer to engineering drawings and schematics for specific details.

The following manuals are available for each cold deck:

Operator Manual	Describes the basic startup, operation, shut down and daily maintenance of the cold deck.
Service Manual	Describes the installation, startup, operation, shut down and maintenance the cold deck. Refer to the <i>LSR Cold Deck Service Manual</i> for product specific instructions.

These manuals are available online through www.husky.co.



IMPORTANT!

Some manuals may contain addendums that detail new or updated information. Before reading a manual, make sure to review all available addendums located at the end of the manual.

1.7 Engineering Drawings and Schematics

Each Husky cold deck is provided with a set of drawings and schematics specific to the cold deck. These are used for troubleshooting the cold deck and ordering spare parts.

Each drawing and schematic is specific to the cold deck it is provided with.

1.8 Safety Alert Conventions

Safety alerts highlight hazardous conditions that may arise during installation, operation or maintenance and describe methods for avoiding personal injury and/or property damage.

Depending on the severity of the hazard, safety alerts start with one of the following signal words: Danger, Warning or Caution.

**DANGER!**

The **DANGER** safety alert indicates an imminently hazardous situation that, if not avoided, will result in death or serious injury.

**WARNING!**

The **WARNING** safety alert indicates a potentially hazardous situation that, if not avoided, could result in death or serious injury.

CAUTION!

The **CAUTION** safety alert indicates a potentially hazardous situation that, if not avoided, could result in property damage.

Other non-safety related alert types used in the manuals highlight important information needed by the user to install, operate or maintain the equipment properly. They may also, in some cases, describe best practices, offer an expanded explanation, or reference a related section in the manual.

Non-safety related alerts start with one of the following signal words: Note or Important.

NOTE:

The **NOTE** alert is used to add information to a subject that does not fit within the general flow of the document.

**IMPORTANT!**

The **IMPORTANT** alert is used to highlight important steps, conditions, or considerations related to the subject.

1.9 Training

All designated operators and maintenance personnel must be fully trained before using or servicing Husky injection molding systems.

If training is required, visit www.husky.co or contact your nearest Husky Regional Service and Sales office to learn more about Husky's training solutions.

**IMPORTANT!**

It is the obligation of the employer to properly train and instruct all personnel in the safe methods of operation and maintenance. Manuals and other reference material, which have been prepared by Husky for the operation and maintenance of Husky equipment, do not in any way absolve the employer from fulfilling these obligations and Husky disclaims liability for injury to personnel which is attributable to the employer's failure to do so.

1.10 Special Tools

The following sections list various component-specific tools developed by Husky for use during maintenance of cold deck systems. Contact Husky to order special tools applicable to your cold deck system.

1.10.1 Valve Stem Removal Tools

Description	Part Number
VG-LX	4793599
VG-EX	4793600

1.10.2 Backup Pad Removal Tools

Description	Part Number
LSR 500	2603927

1.10.3 Double Delta Seal Installation Tools

Description	Part Number
LSR 500 LX	3087823
LSR 500 EX	12517375

1.10.4 Thermocouple Wire Stripping Tools

Description	Part Number
Strippers for thermocouple wires	4240042

1.10.5 Crimping Tools for Contact Pins (25 or 64 Pin Connectors)

Description	Part Number	
Crimp Tool	2292562	
Locator	2292574	
Removal Tool	534645	
Crimp Dies	0.5 to 1.5 mm ² (20 to 16 AWG) ^[1]	238569
	4.0 to 10 mm ² (12 to 8 AWG) ^[1]	2292575
	0.14 to 4.0 mm ² (26 to 12 AWG) ^[2]	2292576
	0.14 to 0.5 mm ² (26 to 20 AWG) ^[1]	2748316
	1.5 to 2.5 mm ² (16 to 14 AWG) ^[1]	2748326

^[1] Stamped crimp pins.

^[2] Machined crimp pins.

Chapter 2 Safety Summary

This chapter describes the general requirements and conditions for safe installation, operation and maintenance of the cold deck.

**IMPORTANT!**

Personnel must read, understand and follow all safety precautions.

**IMPORTANT!**

Personnel must follow applicable industry and regulatory safety requirements for safe installation, operation and maintenance of equipment.

2.1 Qualified Personnel

Only fully trained and qualified personnel should be permitted to maintain equipment. Qualified personnel must have demonstrated skills and knowledge related to the construction, installation and operation of the injection molding equipment and have received safety training on the hazards involved.

2.2 Safety Guidelines

Personnel operating, installing, maintaining or servicing Husky equipment must adhere to safe working practices that are in compliance with the following guidelines:

- Lockout and tag electrical, pneumatic and hydraulic energy sources before servicing the mold/cold deck or entering the mold area
- Do not operate the mold/cold deck if scheduled preventive maintenance has not been performed
- Do not use a magnetic platen without approval from Husky and the magnetic platen supplier/manufacturer
- Do not operate a cold deck outside the temperature ranges specified on the cold deck nameplate

2.3 Safety Hazards

Some common safety hazards associated with injection molding equipment are:

- Mechanical
- Electrical
- Burn
- High pressure (hydraulic system pressure)
- Slip, trip or fall
- Lifting
- Gas, vapor and dust emissions
- Noise

2.3.1 Mechanical Hazards

- **Worn Hoses and Safety Restraints**
Regularly inspect and replace all flexible hose assemblies and restraints.
- **Cooling Water Hoses**
Cooling water hoses degrade over time and need to be replaced on a yearly basis. Degraded hoses become brittle and can break or separate from the fitting when manipulated. To minimize the risk of failure, inspect the hoses regularly and replace as required.
- **Seized Screws or Plugs**
If screws or plugs cannot be removed by normal methods using standard tooling and force, there is a high possibility these items have become seized; contact Husky for repair recommendation.



WARNING!

Mechanical and/or flying debris hazard - Tool breakage: risk projectile debris, serious injury and/or mechanical damage. Do not use excessive force and/or use tools beyond their designated limits. Do not use torque multiplying bars. Failure of tools may produce fragments that can become projectiles that may cause injury. For seized parts, consult Husky for safe disassembly instructions.



IMPORTANT!

In the event of water leaking onto or into the cold deck, the nozzle tips must be removed (cold) and the cured LSR in the nozzles drilled out to ensure they are open to atmosphere. This can be done using a standard twist drill with the cutting edges removed to prevent damage to the melt channel.

Replace the cavity plate prior to heating the system.

2.3.2 Burn Hazards

Hot Surfaces

The mold area, auxiliary and mold equipment have numerous high temperature surfaces. At normal operating temperatures, contact with these surfaces will cause severe skin burns. These areas are clearly marked with safety signs. Wear personal protective equipment when working in these areas

2.3.3 Electrical Hazards

Water

Water on the cold deck can be in close proximity to electrical connections and equipment. This can lead to a short circuit, resulting in serious electrical damage to the equipment. Always keep water lines, hoses, and hose fittings in good condition to avoid leaks.

2.3.4 Gas, Vapor and Dust Emissions

Certain processed materials release harmful gas, vapors or dust. Install an exhaust system according to local codes.

2.3.5 Slip, Trip or Fall Hazards

Do not walk, stand, climb or sit on machine surfaces not approved for safe access.

Do not step on the tie bar or any surfaces with grease and/or oil.

Use a safety approved platform, walkway and step ladders designated to access areas that are not accessible from the floor.

2.3.6 Lifting Hazards

When lifting equipment, use suitable lifting devices, proper balancing techniques and designated lifting points. Refer to the installation details, and to handling and lifting instructions. Do not exceed the rated capacity of the lifting equipment.

2.3.7 Pneumatic Hazards

- **Air Supply Hoses**

Make sure air supply hoses connected to the cold deck do not interfere with moving parts of the mold or the machine during operation. All air hoses must be sufficiently long so they will not be strained when the mold halves separate.

- **Compressed Air**

Never use compressed air to clear valve gates. A piece of resin can fly out and injure a bystander.

Always use a brass tool and vacuum cleaner to clear valve gates.

2.4 Safety Signs









Safety signs clearly mark potentially hazardous areas in or around equipment. For the safety of personnel involved in equipment installation, operation and maintenance, use the following guidelines:





- Verify that all signs are in the proper locations. Refer to the drawing package for details.
- Do not alter signs.
- Keep signs clean and visible.
- Order replacement signs when necessary. Refer to the drawing package for part numbers.

The following safety symbols may appear on safety signs:

NOTE:

Safety signs may include a detailed explanation of the potential hazard and associated consequences.

Safety Symbol (ANSI)	Safety Symbol (ISO)	General Description of Symbol
		<p>General</p> <p>This symbol indicates a potential personal injury hazard. It is usually accompanied by another pictogram or text to describe the hazard.</p>
		<p>Hazardous Voltage</p> <p>This symbol indicates a potential electrical hazard that will cause death or serious injury.</p>
		<p>High Pressure Molten Material</p> <p>This symbol indicates the presence of a high pressure molten material hazard that could cause death or severe burns.</p>
		<p>Lockout/Tagout</p> <p>This symbol identifies an energy source (electrical, hydraulic or pneumatic) that must be de-energized before maintenance is performed.</p>
		<p>Crushing and/or Impact Points</p> <p>This symbol indicates a crushing and/or impact area that could cause serious crushing injury.</p>

Safety Symbol (ANSI)	Safety Symbol (ISO)	General Description of Symbol
		<p>High Pressure</p> <p>This symbol indicates a heated water, steam or gas hazard that could cause severe injury.</p>
		<p>High Pressure Accumulator</p> <p>This symbol indicates the sudden release of high pressure gas or oil could cause death or serious injury.</p>
		<p>Hot Surfaces</p> <p>This symbol identifies the presence of exposed hot surfaces that could cause serious burn injuries.</p>
		<p>Slip, Trip or Fall Hazard</p> <p>This symbol indicates a slip, trip or fall hazard that could cause injury.</p>
		<p>Do Not Step</p> <p>This symbol identifies a location that should not be used as a step because it may be a slip, trip or fall hazard and could cause injury.</p>
		<p>Crushing and/or Shearing Hazard</p> <p>This symbol indicates the presence of a crushing and/or shearing hazard at the rotating screw that could cause serious injury.</p>
		<p>Read Manual Before Operation</p> <p>This symbol indicates that qualified personnel should read and understand all instructions in the equipment manuals before working on the equipment.</p>
		<p>Class 2 Laser Beam</p> <p>This symbol indicates a laser beam hazard that could cause personal injury with prolonged exposure.</p>
		<p>Barrel Cover Grounding Strap</p> <p>This symbol indicates an electrical hazard related to the barrel cover grounding strap that could cause death or serious injury.</p>

Safety Symbol (ANSI)	Safety Symbol (ISO)	General Description of Symbol
		<p style="text-align: center;">Do Not Grease</p> <p>This symbol indicates greasing is not required under normal operating conditions. Greasing could cause equipment failure.</p>

2.5 Lockout and Tagout

A lockout/tagout procedure in accordance with local codes must be performed on the machine, controller and auxiliary equipment before any maintenance activities are performed while in the machine or connected to an external energy source.



WARNING!

Complete the Lockout/Tag out of all energy sources in accordance with applicable local codes before performing maintenance activities. Failure to do so could result in serious injury or death. Refer to the machine and associated equipment manufacturer’s manual for instructions.

Only qualified personnel should be permitted to install and remove locks and tags.







Lockout and tagout includes: the isolation of energy; depletion of stored energy; and prevention of re-energization from all energy sources.

2.6 Personal Protective Equipment and Safety Equipment

Personal injury can be avoided when personnel wear appropriate protective gear and use special safety equipment. The following describes the safety gear and equipment that should be used when working with the machine and any auxiliary equipment.

2.6.1 Personal Protective Equipment (PPE)

Wear appropriate personal protective equipment when working on or near equipment. Standard personal protective equipment includes:

Item	Description
	<p>Safety Glasses For protecting the eyes from flying objects/particles, heat, sparks, splash from molten material, and more.</p>
	<p>Face Shield For protecting the entire face area from flying objects/particles, heat, sparks, splash from molten material, and more.</p>
	<p>Heat Resistant Gloves For protecting the hands from extreme heats.</p>
	<p>Hearing Protection For protecting the ears from loud ambient noise.</p>
	<p>Safety Shoes For protecting the feet from electrical shocks, crushing hazards, puncture hazards, splash from molten material, and more.</p>
	<p>Non-Melting Natural Fiber Pants and Long Sleeved Shirt For protecting the body from abrasions, cuts, and potential splash from molten material.</p>

2.6.2 Safety Equipment

Use appropriate safety equipment when working on or near equipment.

Standard safety equipment includes:

- **Vacuum Cleaner**
For collecting spilled resin pellets and other debris that may create a falling hazard
- **Stairs and Ladders**
For ensuring safe access to areas of the machine

- **Danger Signs**
For warning other personnel to stand clear of a component or area of the machine
- **Locks and Tags**
For preventing the use of specific systems and components
- **Fire Extinguishers**
For the expedient suppression of small fires
- **Telescopic Mirror**
For safely inspecting cold deck nozzle tips from outside the mold area
- **Brass Hammers and Brass Rods**
For safely removing dried resin deposits

2.7 Material Safety Data Sheet (MSDS)



WARNING!

Chemical hazard - Some of the chemicals used with Husky equipment are potentially hazardous and could cause injury and illness. Before storing, handling, or working with any chemical or hazardous material, thoroughly read and understand each applicable Material Safety Data Sheet (MSDS), use recommended personal protective equipment and follow the manufacturer’s instructions.

The Material Safety Data Sheet (MSDS) is a technical document which indicates the potential health effects of a hazardous product. It contains safety guidelines to protect personnel, as well as information about use, storage, handling, and emergency procedures.

Always refer to the applicable Material Safety Data Sheet before doing the following:

- handling a chemical product
- disassembling any portion of Husky equipment that may result in exposure to a chemical product

Contact the material supplier to obtain a copy of the MSDS sheet.

2.8 Materials, Parts and Processing

To prevent personal injury or damage to the equipment, make sure of the following:

- The equipment is only used for its intended purpose, as described in the manuals
- The operating temperatures do not exceed the specified permissible maximum value for the LSR

- The maximum temperature set point is set below the flash point of the material being processed
- Lubricants, oils, process materials and tools used on equipment meet Husky specifications
- Only authentic Husky parts are used

2.9 Safety Latch Bars

The following sections list various component-specific tools developed by Husky for use during maintenance of cold deck systems. Contact Husky to order special tools applicable to your cold deck system.

Safety latch bars are used to hold plates together for maintenance and installation purposes. They provide a safe means for transporting and handling the assembly, and for securing plates that are normally fastened together during normal operation.



WARNING!

Crushing hazard – risk of death or serious injury. Plates could separate from each other and fall during handling if not properly secured. Under no circumstances are multiple plates to be handled with only one safety latch bar installed.

Safety latch bars must always be installed in pairs on diagonally opposite sides of the mold and cold deck assembly to provide equal pull on the plates.

NOTE:

Specific instructions on how to install safety latch bars are provided when needed in this manual.

2.10 Lift Bars and Swivel Hoist Rings

Every mold and cold deck assembly is equipped with tapped lift holes for lifting either the complete assembly or individual plates. Husky only supplies special lifting equipment (including a lift bar and swivel hoist rings) when required. This lifting equipment is designed specifically for the mold/cold deck assembly. When Husky provides special lifting equipment, use only Husky specified and supplied lifting equipment.

NOTE:

Separate lift bars for the hot and cold halves of the mold and cold deck assembly may be provided based on the requirements of the assembly.

**IMPORTANT!**

Make sure all lifting equipment is rated for the load and in safe operating condition. Follow the recommendations and use care when moving or handling plates or assemblies.

For instructions about lifting plates and plate assemblies and using the Husky provided lift bar and swivel hoist rings, refer to [Section 4.1](#).

NOTE:

The Husky provided lift bar, swivel hoist rings and associated hardware must be stored together while the mold, cold deck, tooling plate and CoolPik plate are in operation.

Chapter 3 Specifications

This chapter outlines the necessary temperature, electrical, air and lubricant information needed to operate and maintain the cold deck.

3.1 Weight

The full weight of the cold deck assembly is listed on the assembly drawings.

3.2 Operating Temperature

The cold deck must operate within a specific temperature range to prevent internal LSR leakage and damage to internal components. This temperature range is listed on the cold deck nameplate as the temperature difference between the manifold and the mold.



IMPORTANT!

The temperature range is critical for the cold deck system to be able to create a proper seal. It is important the designed operating temperature window be observed at all times.

For more information about the nameplate, refer to [Section 1.5](#).

3.3 Electrical Specifications

Refer to the electrical schematic for the following information:

- Control zones
- Multi-pin connector and pin positions for each thermocouple wire
- Keypin locations

3.3.1 Controller Requirements

The number of control zones required for the thermocouple will depend on the size and requirements of the basic system.

3.3.2 Manifold Temperature Control

Whenever possible, the manifold is controlled by a single controller zone. The circuit will be completed either at the cable connector or at the manifold.

A spare thermocouple for each zone is also be routed to the base of the multi-pin connector to minimize down time. Should the main thermocouple fail, the spare can be easily connected without having to disassemble the mold. The failed thermocouple can be replaced at the next maintenance interval.

The spare thermocouples can also be used to verify the condition of the first thermocouple should a sensing problem develop.

Each Manifold is connected to a separate controller zone with its own thermocouple.

3.3.2.1 Thermocouple Wires

The temperature of each manifold zone is sensed by a J-type thermocouple.

NOTE:

Special order thermocouples may be other types.

NOTE:

To establish proper polarity when connecting thermocouples, follow the electrical schematic. For J-type thermocouples, the white wire is positive (+) and the red wire is negative (-). This wire color coding follows the ANSI J-Type North American Standard. The color coding and wire composition for J-type thermocouples in other parts of the world may be different and produce different readings.

3.4 Pneumatic Specifications

Pneumatic pressure is used to actuate the valve stems. Compressed air for the pneumatic system must meet the following requirements:

- The pressure dew points must be set to 11 °C (20 °F) below the lowest ambient temperature of the pneumatic system in order to keep compressed air clean and dry.
- Compressed air quality must meet the standards specified in DIN ISO 8573-1.
 - Solid particles - Class 1
 - Humidity - Class 4
 - Oil - Class 1
- Typical air pressure required is 5.52 to 8.27 bar (80 to 120 psi) , unless otherwise specified in the mold manufacturer's documentation.

NOTE:

For many pneumatic VG applications, air pressure of 7 bar (100 psi) may be sufficient, while some applications may require up to 12.5 bar (180 psi) for optimal and stable performance.

-
- Compressed air hoses must be large enough to permit adequate flow to the locations where air is required.
 - Compressed air used for mold actuators must be interlocked with the machine operator's gate, so opening the gate prevents any motion.
 - Quick exhaust valves must be located close to the actuators they control, so the compressed air in the mold will decompress rapidly and speed operation of the actuator.
 - Lockout valves must be installed (according to ANSI Z244.1 or local regulations) to the air supply for use when:
 - Serving the mold
 - Performing maintenance
 - Installing and removing the mold

3.5 Recommended Lubricants

The following are recommended lubricants to be used during the assembly and maintenance of Husky cold decks:

NOTE:

Husky recommends only the following lubricants and assumes no responsibility for lubricants not specified. It is the customer's responsibility when consulting with an alternate supplier to make sure a suitable equivalent is used.

NOTE:

Lubricants of inferior quality can cause premature wear of components

**WARNING!**

Chemical hazard - Some of the chemicals used with Husky equipment are potentially hazardous and could cause injury and illness. Before storing, handling, or working with any chemical or hazardous material, thoroughly read and understand each applicable Material Safety Data Sheet (MSDS), use recommended personal protective equipment and follow the manufacturer's instructions.

CAUTION!

Contamination hazard – risk of contaminating lubricants or greases. Do not mix different brands or grades of lubricants or greases. Mixing lubricants or greases can cause premature breakdown of the lubricant or grease and could result in equipment damage.



WARNING!

Poison hazard – risk of death or serious injury. Some recommended lubricants may contain toxic and/or non-ingestible additives and may not be Food and Drug Administration (FDA) approved under the United States Department of Agriculture (USDA) rating H1 (formerly AA). Consult with the lubricant manufacturer for specific details.

Type/ Description	Trade Name	Part Number	Quantity	Used For
Silicone Grease	NOVAGARD G661	534526	150 g (5.3 oz) Squeeze Tube	O-ring seals ^[1]
High temperature Anti-seize lubricant	Loctite Nickel Anti- Seize 771	5541918	225 g (8 oz) can	Screws between cavity plate and cold deck
Protective spray	LPS 2 Lubricant	1501808	566 g (20 oz) Non-Aerosol Spray Bottle	Cold deck plates

^[1] Apply only as directed. Refer to maintenance procedures and/or assembly drawings for more information.

3.6 Rust Inhibitor Specifications

Any rust inhibitor used on the mold must meet the following specifications:

Type	Trade Name
Protective Spray	LPS 2 Protective Spray

3.7 Torque Specifications

Torque specifications are provided on the assembly drawings.

CAUTION!

Mechanical hazard – risk of damage to the cold deck. Use of improper torque can result in equipment damage. Always consult the assembly drawings for torque specifications.

Chapter 4 Installation and Removal

This chapter describes how to install and remove the cold deck assembly.



IMPORTANT!

The procedures contained in this chapter were written for a standard cold deck and do not take special options into consideration.

4.1 Lifting and Handling

The following procedures describe how to safely lift plates and plate assemblies.

CAUTION!

Mechanical hazard – risk of damage to the cold deck. Do not lift plates using magnetic lifting devices. These devices could potentially scratch a finely ground plate.



IMPORTANT!

Safety must be the primary consideration when lifting and moving a plate. Make sure to always use suitable lifting equipment that is inspected regularly and follow the recommendations outlined in this manual.



IMPORTANT!

Every mold and cold deck assembly is equipped with tapped lift holes for lifting either the complete assembly or individual plates. Husky only supplies special lifting equipment (including a lift bar and swivel hoist rings) when required. This lifting equipment is designed specifically for the mold/cold deck assembly. When Husky provides special lifting equipment, use only Husky specified and supplied lifting equipment. Use Husky special lifting equipment to lift only the designated mold or cold deck or component.



WARNING!

Crushing hazard – risk of death or serious injury. Inadequate lifting equipment could fail and cause death or serious injury. Use only Husky specified or supplied lifting equipment.



WARNING!

Crushing hazard – risk of death or serious injury. Misuse of lifting equipment could lead to equipment failure and cause death or serious injury. Use Husky only specified or supplied lifting equipment for lifting the assembly or the component for which the equipment has been designated by Husky.

4.1.1 Lifting and Handling Using a Single Lifting Point

The following procedures describe how to lift and lower plates using a single lifting point.

4.1.1.1 Laying Down Plates Using a Single Lifting Point

To properly lay a plate on a work surface using a single lifting point, do the following:



WARNING!

Crushing hazard – risk of death or serious injury. Inadequate lifting equipment can fail and could cause death or serious injury. Make sure all lifting equipment is rated for the load and in safe operating condition.

1. Install a lift bar or swivel hoist ring and connect it to an overhead lifting device.
 - For information about lifting using a lift bar, refer to [Section 4.1.3](#).
 - For information about lifting using swivel hoist rings, refer to [Section 4.1.4](#).
2. Lift the plate above the work surface.

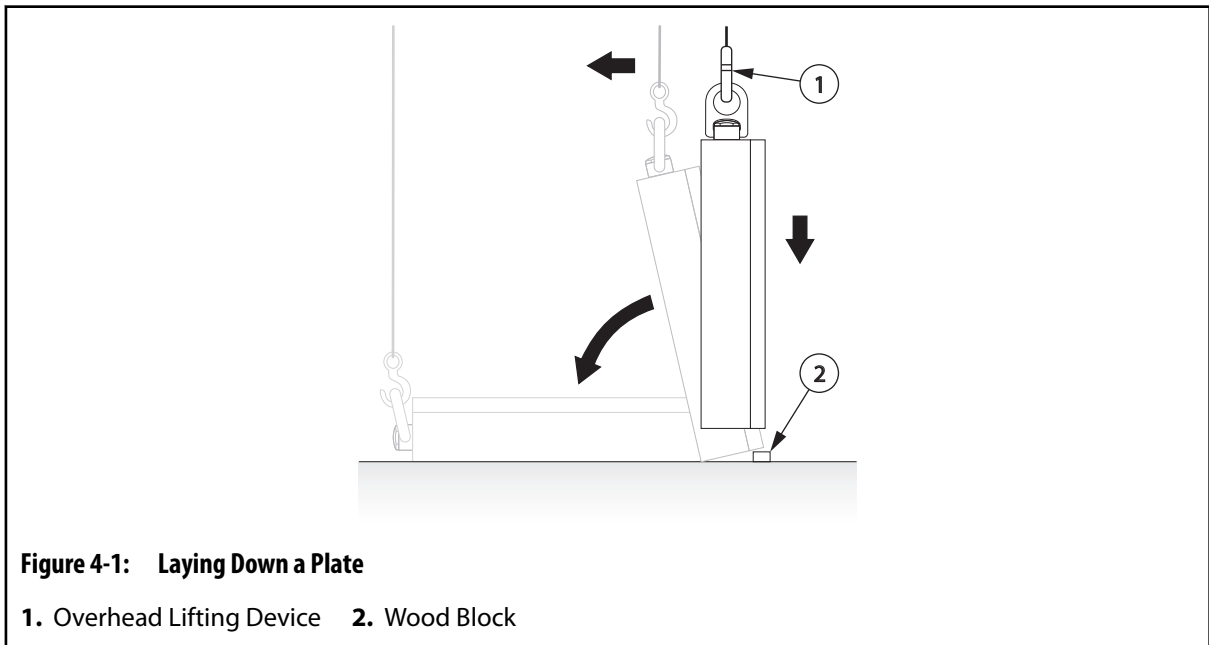

3. Secure a wood block to the work surface on the side opposite the area where the plate will be laid down.

4. Lower the plate slowly onto the edge of the secured wood block.
5. Continue to slowly lower the plate until it tips over towards the work surface.
6. Lay the plate down on the work surface.

4.1.1.2 Picking Up Plates Using a Single Lifting Point

When lifting a plate that has been laid down using a single lifting point, the lifting device may go slack just as the load is in its full vertical position. This may cause the plate to swing over-center in the opposite direction.

To prevent this from happening, do the following:



WARNING!

Crushing hazard – risk of death or serious injury. Inadequate lifting equipment can fail and could cause death or serious injury. Make sure all lifting equipment is rated for the load and in safe operating condition.

1. Install the mold or cold deck lifting equipment lift bar, swivel hoist ring, or other Husky specified lifting equipment and connect it to the overhead lifting device.
 - For information about lifting using a lift bar, refer to [Section 4.1.3](#).
 - For information about lifting using swivel hoist rings, refer to [Section 4.1.4](#).
2. Secure a wood block to the work surface near the foot of the plate. This will prevent the plate from going over-center.

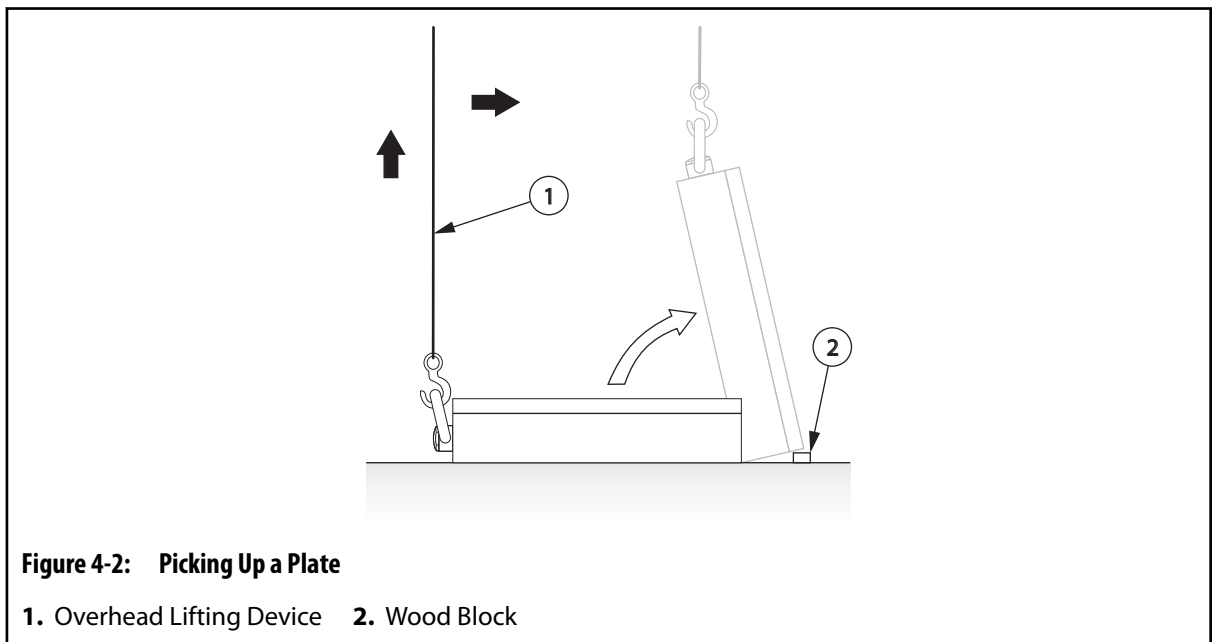

Figure 4-2: Picking Up a Plate

1. Overhead Lifting Device 2. Wood Block

3. Lift the plate until it touches the secured wood block.



WARNING!

Impact hazard – risk of serious injury. The plate could swing in a pendulum motion just as the plate is lifted off of the wood block. Lift slowly to reduce the pendulum motion. Stand clear of the possible swing area to prevent injury.

4. Continue to lift the plate, keeping the tension on the lifting cable.

CAUTION!

Mechanical hazard – risk of damage to equipment. When storing the plate, make sure it is secured in the vertical or horizontal position. Do not rest the plate against another object.

5. After the plate has stabilized, move it to a safe location and remove the wood block.

4.1.2 Lifting and Handling Using Multiple Lifting Points

To lift a plate using more than one lifting point, do the following:



WARNING!

Crushing hazard – risk of death or serious injury. Inadequate lifting equipment can fail and could cause death or serious injury. Make sure all lifting equipment is rated for the load and in safe operating condition.

1. Install the swivel hoist rings in the designated lifting points. Make sure the swivel hoist rings are positioned on opposite sides of the plate to evenly distribute the weight when the plate is lifted vertically.

For information about lifting using swivel hoist rings, refer to [Section 4.1.4](#).

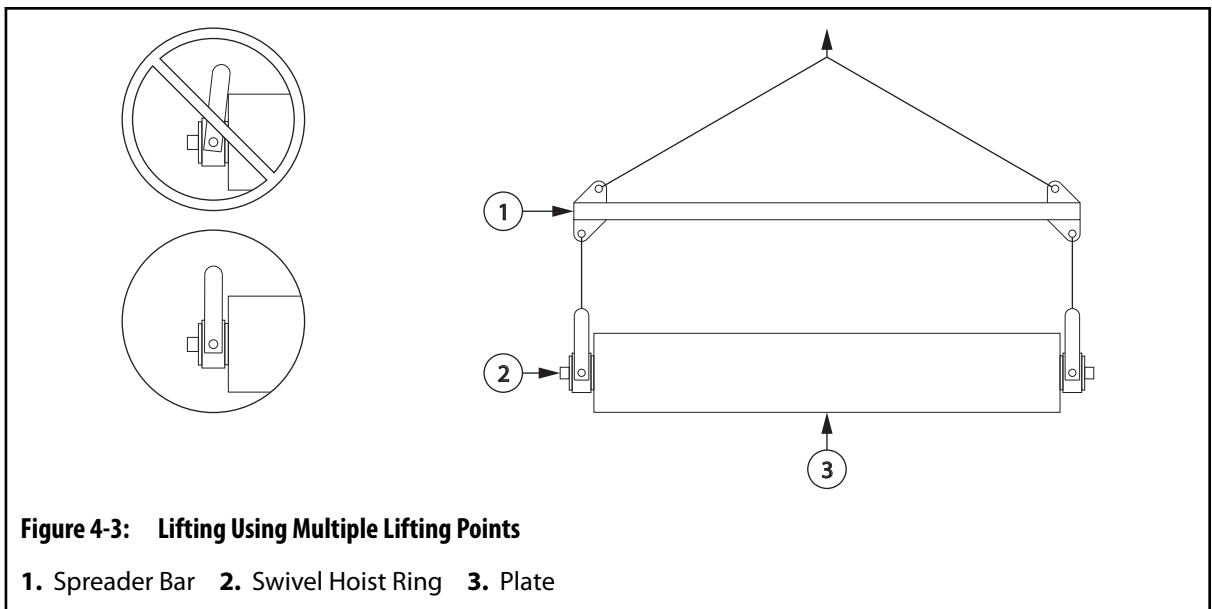

2. Connect the swivel hoist rings to an overhead lifting device. Use a spreader bar if either of the following conditions occur:
 - The pivot angle of any swivel hoist ring exceeds 90°.
 - The angle of lifting cables, slings or chains is less than 45°.
3. Lift the plate and move it to a safe location.

4.1.3 Lifting Using a Lift Bar

To properly lift plates and assemblies using a lift bar, do the following:

NOTE:

For the installation locations of the lift bars, refer to the cold deck for the markings "Lift Bar Only" or to the assembly drawings.

NOTE:

The maximum weight the bar can lift is stamped on the Husky lift bar. If using a lift bar that is not provided by Husky, make sure the lift bar is suitably rated for the weight of the mold/cold deck assembly.

1. Install the lift bar to the lifting holes on the top of the component.

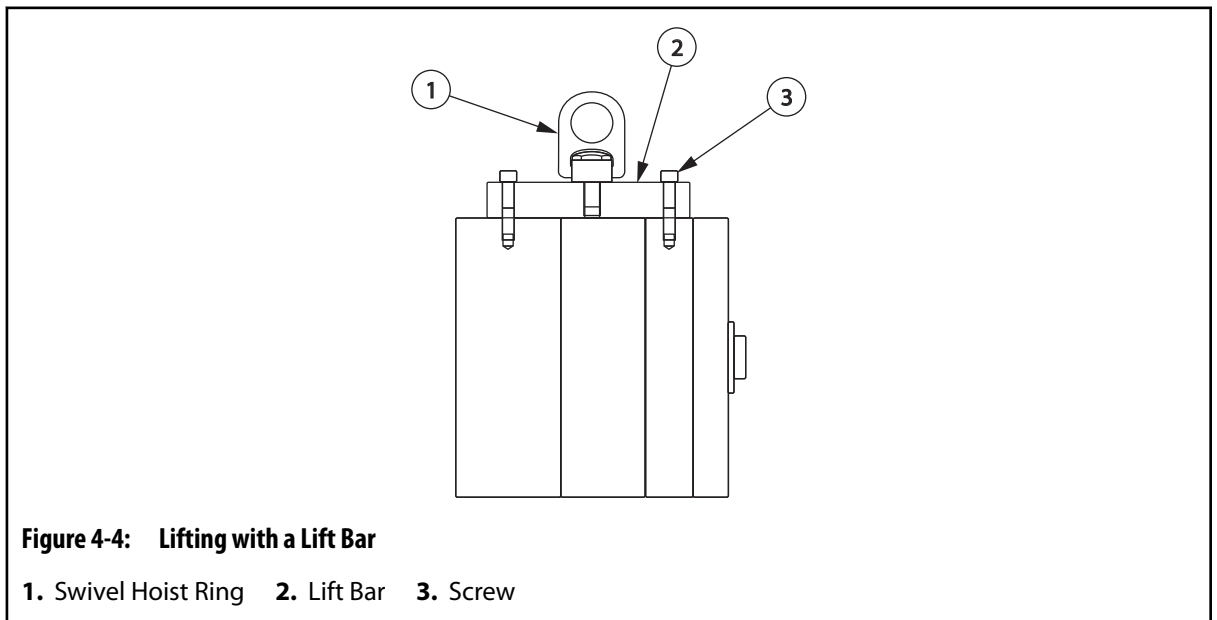

2. Torque the hoist ring to the specified value. Refer to for torque requirements.
3. Attach a suitable overhead lifting device to the swivel hoist ring and lift the plate or plate assembly vertically.
4. While the mold and cold deck are in operation, store the Husky provided lifting equipment together and in a readily accessible area.

4.1.4 Lifting Using Swivel Hoist Rings

When using swivel hoist rings, remember the following:

- For the installation locations of the swivel hoist rings, refer to the cold deck for the markings “Hoist Ring Only” or to the assembly drawings.
- Always make sure the swivel hoist ring is properly torqued before lifting.
- Make sure the swivel hoist ring used can support the weight of the plate or component at the chosen angle of attack.
- Do not lift more than the rated capacity.
- Depending upon the sling angle, the applied load may be more than the weight being lifted. Two point lifting of a 1000 kg (2000 lb) weight, with a sling angle of 30°, will result in an applied load of 1000 kg (2000 lb) to each hoist ring.
- After installation, make sure the hoist ring swivels and pivots freely in all directions. The side of the ring must not contact anything.
- After installation and during operation, store the Husky provided lifting equipment together and in a readily accessible area.
- Never use a hook or other lifting device which will pry or open the “U” shaped bar on center-pull hoist rings.
- Screws must be tightened to the recommended torque values.
- Do not apply shock loads. When lifting, apply force gradually.
- Do not use spacers between the hoist ring bushing and the work piece surface.
- The work piece surface must be flat, providing complete contact for the hoist ring bushing.

Metric and Imperial swivel hoist rings are available through your nearest Husky Parts Distribution Center.

Swivel hoist rings purchased from other suppliers must meet or exceed the following specifications.

Table 4-1: General Hoist Ring Specifications

Category	Specification
Material	4140 certified aircraft quality
Type	Forged hoist ring
Finish	Phosphate per DOD-P-16232F
Safety Factor	5:1
Swivel	Pivot 180° and swivel 360°
Thread	ISO 261 and ISO 965 - Coarse
Surface	Magnetic particle inspected (ASTM E709-80)
Certification	Individual certificate of conformance with the serial number specified on the hoist ring for traceability

Table 4-2: Specifications for Metric Coarse Swivel Hoist Rings

Part Number	Rated Capacity ^[1]	Torque	Thread Ø	Minimum Full Thread Depth	Pitch
2761800	1050 kg (2315 lb)	37 N·m (27 lbf·ft)	M12	24	1.75
2770570	1900 kg (4189 lb)	80 N·m (59 lbf·ft)	M16	32	2.00
2502267	4200 kg (9259 lb)	311 N·m (229 lbf·ft)	M24	48	3.00
536013	7000 kg (15432 lb)	637 N·m (470 lbf·ft)	M30	60	3.50
2761801	11000 kg (24250 lb)	1085 N·m (800 lbf·ft)	M36	72	4.00
2761803	12500 kg (27558 lb)	1085 N·m (800 lbf·ft)	M42	84	4.50

^[1] Minimum rated capacity at any pull angle (between 0° horizontal pull and 90° vertical pull)

Table 4-3: Specifications for Inch UNC Swivel Hoist Rings

Part Number	Rated Capacity ^[2]	Torque	Thread Ø	Minimum Full Thread Depth	Pitch
2732764	1130 kg (2500 lb)	38 N·m (28 lbf·ft)	1/2	1.0	13
2732765	2260 kg (5000 lb)	135 N·m (100 lbf·ft)	3/4	1.5	10
2760517	4530 kg (10000 lb)	310 N·m (229 lbf·ft)	1	2.0	8
2732766	6800 kg (15000 lb)	640 N·m (472 lbf·ft)	1 1/4	2.5	7
2732767	10880 kg (24000 lb)	1080 N·m (797 lbf·ft)	1 1/2	3.0	6

^[2] Minimum rated capacity at any pull angle (between 0° horizontal pull and 90° vertical pull)

4.2 Mounting Methods

Each cold deck is designed to be mounted to the machine using a specific method. The following describes the various methods that can be used.

4.2.1 Direct Bolting

The direct bolting method uses screws to secure the cold deck to the stationary platen. The screws are either installed through the cold deck into threaded holes in the stationary platen, or through the stationary platen into threaded holes in the cold deck.

In this method, the screws are able to carry the maximum possible load while resisting the opening force of the mold.

When using the direct bolting method, adhere to the following guidelines:

- All screws must be lubricated.
- The size, quantity and spacing of the screws must be suitable for the machine.

CAUTION!

Crushing hazard – risk of damage to equipment. Screws used to secure the cold deck to the stationary platen must meet specific requirements. Only use the screws specified in the assembly drawings. Failure to use these screws could result in equipment damage.

- Make sure only the screws specified in the assembly drawings are used.
- Torque each screw starting from the center of the cold deck and working outwards.

CAUTION!

Mechanical hazard – risk of damage to equipment. Air impact guns could produce excessive torque and damage the cold deck. Use only a torque wrench to install the cold deck.

- Use a torque wrench to install the screws and verify the torque.

4.2.2 Clamping

The clamping method uses clamps to hold the cold deck to the stationary platen. The clamps are secured to the stationary platen with screws and hold the cold deck at the operator and non-operator side clamp slots.

In this method, the clamps must be properly secured to prevent the cold deck from slipping. This may cause damage as the mold closes or cause the mold and cold deck to fall completely from the stationary platen.



WARNING!

Crushing hazard – risk of serious injury, death and/or damage to the cold deck. Clamps could loosen allowing the mold and cold deck to slip or fall completely from the stationary platen. Make sure the type, quantity, size and position of the clamps is sufficient for mounting the mold and cold deck.



IMPORTANT!

Husky assumes no responsibility for the type, quantity, size or position of the clamping equipment used and does not recommend the clamping method for securing the cold deck to the machine. It is the responsibility of the customer to make sure the clamping equipment and its installation is adequate for safely securing the cold deck.

Whenever possible, use the direct bolting method. Refer to [Section 4.2.1](#) for more information.

When using the clamping method, adhere to the following guidelines:

- Make sure the screws used to secure the clamps to the stationary platen are torqued.
- A sufficient number of clamps must be used to safely secure the mold and cold deck.
- The clamps must be positioned as close as possible to each other.
- Verify with the clamp supplier the number of clamps to use, the position and the required torque.
- Only use high strength screws with a minimum yield strength of 690 MPa (100000 psi)
- Inspect and torque the clamps regularly.

4.2.3 Quick Mold Changers and Clamping Systems

Refer to the quick mold changer or clamping system manufacturer's documentation for installation information.



IMPORTANT!

Any quick mold changer or clamping system must be interlocked appropriately with the machine's logic and guarding interlock system.

4.3 Removing and Installing the Cold Deck

The following procedures describe how to remove and install the cold deck.

4.3.1 Installing the Cold Deck



IMPORTANT!

Cold decks may not be put into service in a machine that does not comply with the provisions of Machinery Directive 2006/42/EC, as amended, and with the regulations transposing it into national law.

To install the cold deck in the machine, do the following:

1. Verify the machine nozzle orifice and shape match the sprue bushing in the cold deck. Processing problems can occur if the two systems do not match.
2. Make sure the clamp is open to maximum daylight.
3. Lock out and tag the machine and controller (if equipped). Refer to [Section 2.5](#) for more information.

CAUTION!

Mechanical hazard – risk of damage to equipment. An improperly leveled machine could make the cold deck installation difficult and cause premature component wear. Make sure the machine is leveled before installing the cold deck

4. Make sure the machine is level and the platens are parallel. Refer to the machine manufacturer's documentation for more information.
-

NOTE:

The cavity plate may be attached to the cold deck during installation.

5. Install or remove the cavity plate as needed. Refer to [Section 6.4](#) for more information.
 6. Using a protective spray and a lint-free cloth, clean all mounting surfaces on the cold deck and stationary platen. Refer to [Section 3.5](#) for a list of recommended lubricants.

Remove any hard dirt, nicks or burrs with a medium India stone (240 grit oil stone).
 7. Spray all mounting surfaces on the cold deck and stationary platen with a protective spray. Refer to [Section 3.5](#) for a list of recommended lubricants.
 8. Inspect all fittings and electrical connections on the cold deck for damage. Repair or replace as necessary.
-

**WARNING!**

Crushing hazard – risk of death or serious injury. Inadequate lifting equipment could fail and cause death or serious injury. Make sure all lifting equipment is rated for the load and in safe operating condition.

9. Install and torque the lift bar to the cold deck. Refer to [Section 3.7](#) for more information.
-

**WARNING!**

Crushing hazard – risk of death or serious injury. Inadequate lifting equipment could fail and cause death or serious injury. Make sure all lifting equipment is rated for the load and in safe operating condition.

10. Attach an overhead lifting device to the lift bar and lift the cold deck over the mold area. Make sure the locating ring faces the stationary platen.
 11. Lower the cold deck into the mold area. If necessary, rotate the assembly 90° to fit it between the tie bars.
 12. Align the locating ring with the sprue nozzle and position the backing plate against the stationary platen.
-

CAUTION!

Crushing hazard – risk of damage to equipment. Screws used to secure the cold deck to the stationary platen must meet specific requirements. Only use the screws specified in the assembly drawings. Failure to use these screws could result in equipment damage.

-
13. Secure the backing plate to the stationary platen. Refer to [Section 4.2](#) for information about various mounting methods.
 14. Disconnect the overhead lifting device and remove the lift bar.

CAUTION!

Mechanical hazard – risk of damage to equipment. When installing hoses, make sure they are not routed over edges or positioned where they could rub together, causing motion or vibration damage.

-
15. Connect the cooling hoses to the cold deck.
 16. Connect the supplied thermocouple cables to the designated ports on the cold deck and controller.

CAUTION!

Mechanical hazard – risk of damage to equipment. When installing cables, make sure they are not routed over edges, positioned where they could rub together, or near moving parts. The resulting motion or vibrations could damage the cable insulation.

-
17. Arrange the cables, using clamps or ties if necessary, to avoid contact with moving parts or sharp edges.

**WARNING!**

Poison hazard – risk of death or serious injury. The mold may have been sprayed with a rust inhibitor that could be toxic if ingested. To avoid contamination of food packaging products, this inhibitor must be completely removed. Clean all molding surfaces with an appropriate molding surface cleaner and discard all molded products until all traces of the rust inhibitor are removed.

-
18. If the cavity plate is installed on the cold deck, remove the rust inhibitor from all molding surfaces on the cavity plate using an appropriate molding surface cleaner.
 19. Remove all locks and tags.

4.3.2 Removing the Cold Deck

To remove the cold deck from the machine, do the following:

1. Lock out and tag the machine and controller (if equipped). Refer to [Section 2.5](#) for more information.

2. Purge all cooling water from the cooling hoses to minimize the risk of a coolant spill should a hose come loose during maintenance. Refer to the machine manufacturer's documentation for more information.
3. Disconnect all cooling hoses from the cold deck.
4. Disconnect all electrical cables and connectors from mold and cold deck.

**WARNING!**

Crushing hazard – risk of death or serious injury. Inadequate lifting equipment could fail and cause death or serious injury. Make sure all lifting equipment is rated for the load and in safe operating condition.

5. Install and torque the lift bar to the cold deck. Refer to [Section 4.1.3](#) for more information.
6. Attach an overhead lifting device to the hoist ring and lift only until the lifting chain has a slight tension on it.
7. Disconnect the backing plate from the stationary platen starting on the non-operator side, followed by the operator side.
8. Lift the cold deck out of the clamp. If necessary, rotate the cold deck 90° to fit it between the tie bars.

**WARNING!**

Crushing hazard – risk of death or serious injury. Do not work under suspended loads. To prevent injury, install safety blocks.

9. Install feet on the bottom of the cold deck to protect the hose fittings (if applicable).

CAUTION!

Mechanical hazard – risk of damage to equipment. Store and secure the cold deck in the vertical or horizontal position. Do not rest the assembly against another object.

CAUTION!

Mechanical hazard – risk of damage to the cold deck. The cold deck must be set on supports if it is laid down horizontally, such as on a work bench. Damage to the nozzle tips, sprue bar and/or wires could occur.

10. Move the cold deck to a safe location.

Chapter 5 Startup and Operation

This chapter describes how to safely startup and operate the cold deck. Follow these instructions along with any in the machine manufacturer's documentation.

To startup the cold deck for operation, perform the following procedures in order:

Step	Task	Reference
1	Prepare the cold deck	Section 5.1
2	Bring the machine mold and cold deck to operating temperature	Section 5.2
3	Precharge the cold deck with LSR	Section 5.3
4	Produce test parts	Section 5.4



IMPORTANT!

The mold and cold deck must be installed properly by qualified personnel before production begins



IMPORTANT!

Cold decks may not be put into service in a machine that does not comply with the provisions of Machinery Directive 2006/42/EC, as amended, and with the regulations transposing it into national law.

5.1 Preparing the Cold Deck

To prepare the cold deck for startup, do the following:

1. Lock out and tag the machine and controller (if equipped). Refer to [Section 2.5](#) for more information.
2. Make sure the mold and cold deck are installed properly.
3. Make sure the thermocouples are connected to the machine or a controller.
4. Make sure the LSR type in the machine matches the required type indicated on the cold deck nameplate. Refer to [Section 1.5](#) for more information about the nameplate
5. Using compressed air, remove any water around the nozzle tips and parting lines.
6. Make sure the water chiller is enabled and adjusted to the proper operating temperature.
7. Make sure all safety latches have been removed from the mold and cold deck.

8. Remove all locks and tags.

CAUTION!

Mechanical Hazard – Risk of damage to cold deck. Dry cycling the valve stems on a cold deck system is not recommended. Dry cycling can damage the valve stems, nozzle tips, and gate steel. If dry cycling is required for inspection of the cold deck, this should be kept to a minimum. If a long dry cycle of the injection molding machine is required, then it is not recommended to actuate valve stems during this operation.

5.2 Bringing the Cold Deck, Mold and Machine to Operating Temperatures

To bring the mold and machine up to operating temperature, do the following:

1. Make sure the water chiller is enabled and adjusted to the proper operating temperature
2. If equipped, make sure the mold enclosure de-humidifier, air compressor and water tower supplies are enabled.
3. Make sure the compressed air for the mold is turned off. If the compressed air is left on as the mold heats up, air will leak from the system. This will cool the mold and delay the startup.
4. Slowly open the clamp to full shutheight.
5. Turn on the cold deck cooling system.
6. If equipped, turn on the controller.
7. Set the temperature of the main manifold and sprue in cooling system to the LSR temperature indicated on the nameplate. Refer to [Section 1.5](#) for more information about the nameplate.

Wait an additional 10 minutes or more of soak time to make sure the manifold has reached the operating temperature.

8. Make sure the main manifold and the sprue and the nozzles reached the set temperature.
9. Turn on the mold heaters and allow them approximately 1/2 to 1 1/2 hours to reach operating temperature, depending on the size of the mold.
10. Open the process material feed. Refer to the machine manufacturer's documentation for more information.

5.3 Precharging the Cold Deck

To precharge the cold deck with LSR, do the following:

1. Close the clamp and apply tonnage.

**WARNING!**

Liquid silicone rubber spray hazard – risk of serious injury. LSR under pressure can suddenly release and spray out from the machine nozzle. Before purging the injection unit, clear the area of all non-essential personnel and wear Personal Protective Equipment (PPE) consisting of a coat, gloves and a full face shield over safety glasses.

2. Purge the injection unit. Refer to the machine manufacturer's documentation for more information.
3. Clean the machine nozzle, stationary platen and purge guard of any LSR deposits. Refer to the machine manufacturer's documentation for more information.
4. Make sure the machine nozzle is firmly seated against the sprue bushing.
5. While the mold is reaching operating temperature, turn on the extruder screw to fill up the cold deck runners until the injection unit is reaching expected pressure in dosing position.
6. Make sure the valve gates are in the open position or open automatically during injection.
7. Move the machine nozzle forward until it is firmly seated against the sprue bushing.

NOTE:

The cold deck channels are properly filled with LSR when the injection piston stops before making contact with the injection housing.

8. Slowly inject LSR into the cold deck until the injection piston stops. The piston must stop before it makes contact with the injection housing. If the piston makes contact with the injection housing, inject LSR again.
9. Once the injection piston stops, start the extruder screw and make sure it retracts fully.

5.4 Producing Test Parts

To produce test parts that will verify the settings and functions for the cold deck and machine, do the following

1. Make sure the nozzle is at specified temperature with acceptable deviation of 5°C. If the nozzle temperature is above specification, do the following:
 - Enable higher flow rates of the water or set the temperature on the controller at lower temperature.
2. Close the clamp and apply tonnage.
3. Make sure the machine nozzle is firmly seated against the sprue bushing.
4. Reduce the injection pressure to 70 bar (1000 psi) .
5. Disable all ejector functions to prevent the machine from automatically ejecting parts.
6. Cycle the machine once in normal mode to produce a set of parts.
7. Check that all parts have been properly molded.
8. Manually control the ejector functions to eject the parts.
9. If all cavities are producing parts, reset the injection pressure to the recommended value.

- 10.** Cycle the machine four times in normal mode to produce parts. This will remove any air trapped in the LSR.
- 11.** Visually inspect the last set of parts to verify the part quality. Repeat [step 10](#) until the part quality is satisfactory
- 12.** Enable the ejector functions.
- 13.** If equipped, enable the product handling equipment.
- 14.** Cycle the machine 10 times in semi-cycle mode. During each cycle, if equipped, make sure the product handling equipment properly transfers the parts to the conveyor.
- 15.** Enable the auto-cycle mode for the machine and begin production.

Chapter 6 Maintenance

This chapter describes the maintenance tasks required to maintain the cold deck. Refer to [Section 6.1](#) for a full list of maintenance procedures.

NOTE:

Unless specified otherwise, all bolts, screws, fittings and other hardware should be torqued to the values listed on the assembly drawings specific to the cold deck.

**WARNING!**

Risk of injury. When entering the molding area, personal protective equipment must be worn to guard against burns, abrasions, hearing, foot, eye, and face hazards and any other procedure specific hazards listed in the manual.

**WARNING!**

Chemical hazard - Some of the chemicals used when servicing or maintaining Husky equipment are potentially hazardous and could cause injury and illness. Before storing, handling, or working with any chemical or hazardous material, thoroughly read and understand each applicable Material Safety Data Sheet (MSDS), use recommended personal protective equipment and follow the manufacturer's instructions.

**IMPORTANT!**

The procedures contained in this chapter were written for a standard cold deck and do not take special options into consideration.

6.1 Scheduled and Non-Scheduled Maintenance

Throughout the life of the mold and cold deck, various systems and components will need to be inspected and serviced on a scheduled or non-scheduled basis.

There are two types of maintenance procedures:

- Preventive procedures are performed at scheduled intervals
- Service procedures are performed when required

6.1.1 Preventive Maintenance

The following procedures must be performed when either the interval or cycle count is reached as part of the recommended preventive maintenance program for the mold and cold deck.

Interval	Cycles	Task Description	Reference
Every 6 Months	800,000	Check tip area for any leakage	Section 6.10
Every 12 Months	1,600,000	Inspect the valve stem and piston assemblies Exchange the O-Ring seal between Valve Stem and Manifold Bushing	Section 6.8
Every 18 Months	2,000,000	Replace the double delta seals Replace O-Ring between Tip and Nozzle Housing	Section 6.9

6.1.2 Service Procedures

The following procedures are to be performed only when needed.

Procedure	Reference
Changing the LSR color	Section 6.2
Measuring preload	Section 6.3
Removing LSR from the cold deck	Section 6.15
Removing LSR from the manifold plate	Section 6.16
Removing and installing manifold bushings	Section 6.12
Removing and installing manifolds	Section 6.6
Removing and installing nozzle housings	Section 6.11
Removing and installing nozzle tips	Section 6.10
Removing and installing the backing plate	Section 6.5
Removing and installing the cavity plate	Section 6.4
Removing and installing the sprue bushing	Section 6.13
Removing and installing valve stems	Section 6.8
Removing and installing VG-LX/EX backup pads	Section 6.7.1
Removing air and water plugs	Section 6.14

6.2 Changing the Liquid Silicone Rubber Color

To change the color of the liquid silicone rubber, do the following:

1. Lock out and tag the machine and controller (if equipped). For machine lockout and tag procedures refer to the machine documentation.
2. Remove all traces of the original liquid silicone rubber from the material feed equipment.
3. Depending on application restrictions, add one of the following to the material feed equipment to reduce the cleaning time required:
 - Natural (uncolored) liquid silicone rubber
 - New colored Additive
4. Remove all locks and tags.
5. Power up the machine and turn on the controller (if equipped).



WARNING!

Liquid silicone rubber spray hazard – risk of serious injury. Liquid silicone rubber under high pressure can suddenly release and spray out from the machine nozzle. Before purging the injection unit, clear the area of all non-essential personnel and wear personal protective equipment consisting of a heat-resistant coat, heat-resistant gloves and a full face shield over safety glasses.

6. Purge the injection unit until all traces of the old color are eliminated. For instructions, refer to the machine manufacturer's documentation.
7. Increase the injection speed to the maximum value allowed by the application.
8. Reduce the hold time and cooling time to the minimum values allowed by the application.
9. Repeat [step 3](#) to replenish the material feed system, if required.
10. Produce a series of test parts until all traces of the old color are eliminated.
11. Return the hold time, cooling time and injection speed back to their original values.
12. Fill the material feed equipment with the new liquid silicone rubber.

6.3 Measuring Preload

Preload measurements from various sections of the cold deck must be taken and verified before the plates are assembled and when the cold deck is at room temperature (< 25 °C or < 77 °F). Damage to the plates, backup pads or cylinders, and nozzle stacks could occur if the preload measurements are not within the allowed tolerance.



IMPORTANT!

Always measure preload in more than one section of the cold deck to make sure preload is consistent.

Maintaining proper preload will help prevent LSR and air leaking inside the cold deck.
 Perform the following procedures as applicable to determine the preload on the manifolds.

6.3.1 Measuring Preload for Manifolds in VG-LX and EX Systems

To measure the preload on a manifold, do the following:

1. Determine the height of the backup pads from the assembly drawings. Record the value as measurement *A*.
2. Using a depth micrometer, measure the distance from the top face of the manifold plate to the face of the manifold. Record this value as measurement *B*.

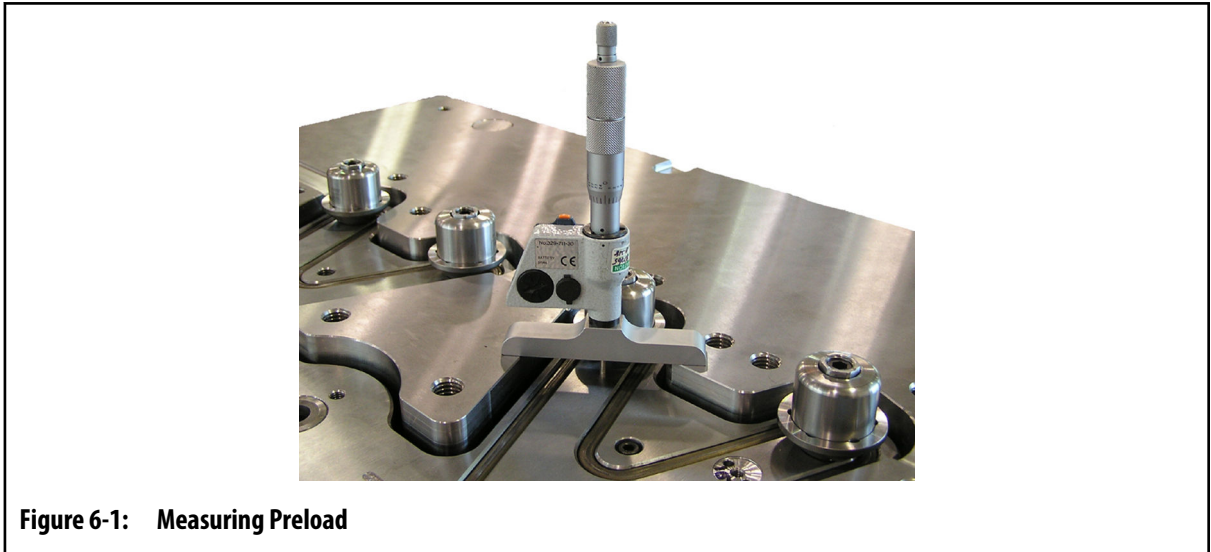

Figure 6-1: Measuring Preload

3. Complete the following calculation to determine the preload:
 $A - B = \text{Preload}$
4. Repeat [step 1](#) to [step 3](#) for all other corners of the manifold to make sure the preload measurements are consistent.
5. Compare the preload values to the C or C1 dimension values listed on the Tip Chart on the assembly drawings.

If the measured preload is not within the tolerances given on the Tip Chart, check all measurements and review the assembly for obstructions or debris. Repeat [step 1](#) to [step 5](#) until the preload measurements are within tolerance.

6.4 Removing and Installing the Cavity Plate

Removing the cavity plate provides access to the nozzle tips and gates. The cavity plate can be removed when cold and the mold /cold deck assembly is in the machine or on a work bench.

6.4.1 Removing the Cavity Plate On a Work Bench

To remove the cavity plate from the cold deck when the assembly is on a work bench, do the following:

NOTE:

The following procedure requires the use of an overhead lifting device. Refer to [Section 4.1](#) for lifting and handling instructions.

1. Remove the cold deck and cavity plate assembly from the machine and set it on a work bench with the nozzles facing up. Refer to [Section 4.3.2](#) for more information.
 2. Remove the screws that secure the cavity plate to the cold deck.
 3. Install leader pin on the cold deck through the installation in the cavity plate.
 4. Install hoist rings in the designated lifting points marked on the cavity plate.
-

CAUTION!

Mechanical hazard – risk of damage to the mold and cold deck. Lift the cavity plate slowly until the alignment dowels are cleared. Damage to the cavity plate and/or alignment dowels could occur.

5. If equipped, install feet on the bottom of the cavity plate to protect the hose fittings.
 6. Move the cavity plate out of the work area. Store the plate in a location where the plate cannot fall or tip over.
 7. Remove any liquid silicone rubber residuals on the nozzle tips or in the cavity plate gate details. Refer to [Section 6.15](#) for more information.
-

6.4.2 Installing the Cavity Plate on a Work Bench

To secure the cavity plate to the cold deck when the assembly is on a work bench, do the following:

NOTE:

The following procedure assumes the cavity plate was removed as described in [Section 6.4.1](#).

NOTE:

The following procedure requires the use of an overhead lifting device. Refer to [Section 4.1](#) for lifting and handling instructions.

CAUTION!

Mechanical hazard – risk of damage to the cold deck. Make sure all valve stems are still in the open position prior to installation.

1. Make sure the cold deck is on a work bench with the nozzle tips facing up. The cold deck must be supported by two blocks.
2. Make sure the nozzle and cavity plate sealing surfaces are clean and free of burrs or oil.

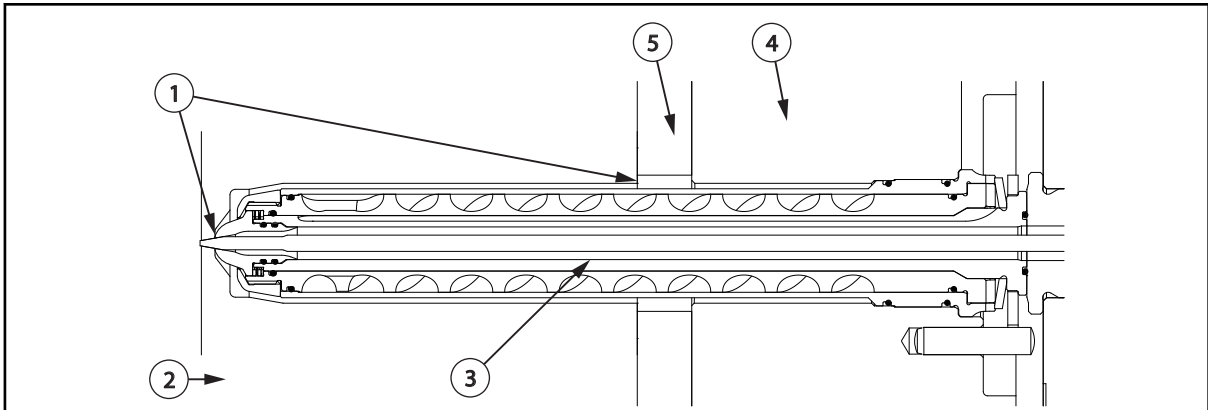

Figure 6-2: Cavity and Nozzle Sealing Diameters

1. Nozzle and Cavity Plate Sealing Diameters 2. Cavity Plate 3. Nozzle Housing 4. Manifold Plate
5. Insulator Board

3. Apply a static application grease to the cold deck alignment dowels. Refer to [Section 3.5](#) for information about recommended lubricants.



WARNING!

Crushing hazard – risk of death or serious injury. Inadequate lifting equipment can fail and cause death or serious injury. Make sure all lifting equipment is rated for the load and in safe operating condition.

4. Install hoist rings in the designated lifting points marked on the cavity plate.
5. Attach an overhead lifting device to the hoist rings and lift the cavity plate over the cold deck.



IMPORTANT!

When assembling the cavity plate to the cold deck, special attention should be given to preventing damage to the nozzle tips and valve stems. The cavity plate should mate with the cold deck without any resistance. If resistance is encountered, remove the plate and check for any interference points.

CAUTION!

Mechanical hazard – risk of damage to equipment. Do not force the plate into position as serious damage to the nozzle tips, valve stems and wires can result.

6. Align the cavity plate with the leader-pins and lower the plate onto the cold deck.
7. Disconnect the overhead lifting device and remove the hoist rings.

8. Remove the feet from the bottom of the cavity plate.
9. Install safety latch bars between the cavity plate and cold deck on both sides of the assembly. A minimum of two safety latch bars are required.
10. Install the screws that secure the cavity plate to the cold deck and torque them to the specified value. Refer to the manufacturer's documentation for torque requirements.
11. Remove the leader pins from the cold deck.

6.4.3 Removing the Cavity Plate in the Machine

To remove the cavity plate from the cold deck when the assembly is in the machine, do the following:

CAUTION!

Mechanical hazard – risk of damage to the cold deck. Do not actuate the valve stems when the liquid silicone rubber is cured. Damage to the valve stems could occur.

1. Cool the mold until it reaches room temperature (< 25 °C or < 77 °F).
2. Open the clamp.
3. Lock out and tag the machine and controller (if equipped). Refer to [Section 2.5](#) for more information.
4. Disconnect wires for thermocouples and heaters of the cavity plate from the electrical box.
5. Install safety latch bars between cavity plate and cold deck on both sides of the assembly. A minimum of two safety latch bars are required.

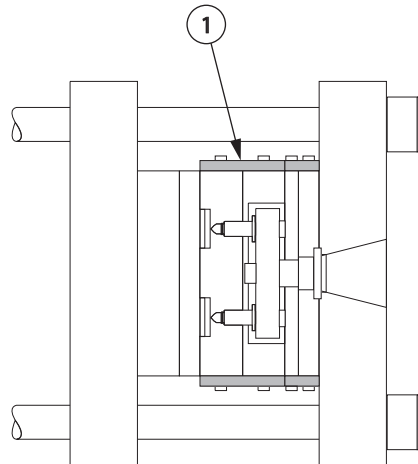

Figure 6-3: Latching the Cavity Plate to the Cold Deck (Overhead View)

1. Safety Latch Bar

6. Remove the screws that secure the cavity plate to the cold deck.
7. Install leader pin through the installation in the cavity plate into the cold deck
8. Remove all locks and tags.

9. Reduce the clamp opening and closing speed.
10. Slowly close the clamp.
11. Lock out and tag the machine and controller (if equipped).
12. Remove all safety latch bars.

CAUTION!

Mechanical hazard – risk of damage to the machine, mold and cold deck. Make sure the hoses attached to the cavity plate are long enough to allow latching without damaging the hoses. In some cases it may be necessary to relieve residual pressure in the system and then disconnect the hoses.

13. Install safety latch bars between the cavity plate and core plate on both sides of the assembly. A minimum of two safety latch bars are required.
14. Remove all locks and tags.
15. Open the clamp.
16. Lock out and tag the machine and controller (if equipped).

6.4.4 Installing the Cavity Plate in the Machine

To secure the cavity plate to the cold deck when the assembly is in the machine, do the following:

NOTE:

The following procedure assumes the cavity plate was removed as described in [Section 6.4.3](#).

1. Lock out and tag the machine and controller (if equipped). Refer to [Section 2.5](#) for more information.
2. Make sure the nozzle and cavity plate sealing surfaces are clean and free of burrs or oil.

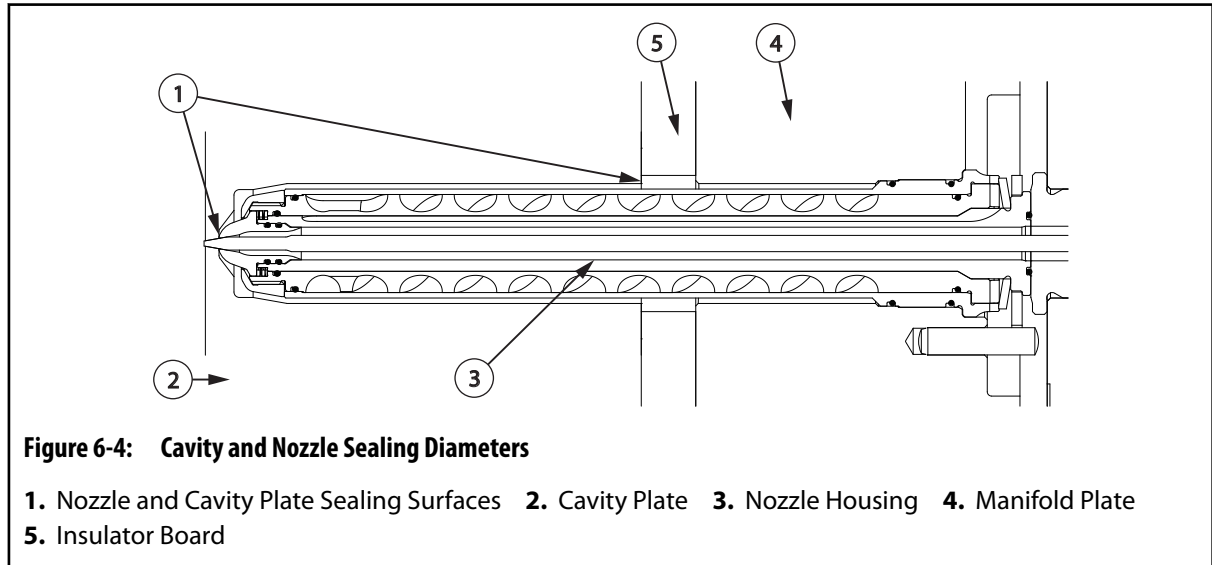

3. Apply a static application grease to the cold deck alignment dowels. Refer to [Section 3.5](#) for information about recommended lubricants.

4. Remove all locks and tags.
5. Reduce the clamp opening and closing speed.
6. Slowly close the clamp to move the cavity plate into position. Make sure the wires in the wire channels are not pinched between the plates while closing.
7. Lock out and tag the machine and controller (if equipped).
8. Remove all safety latch bars.
9. Install safety latch bars between the cavity plate and cold deck on both sides of the assembly. A minimum of two safety latch bars are required.

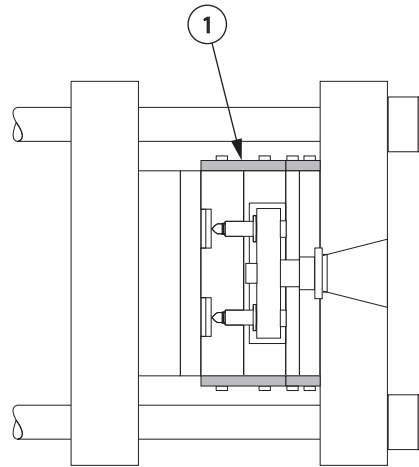

Figure 6-5: Latching the Cavity Plate to the Cold Deck (Overhead View)

1. Safety Latch Bar

10. Remove all locks and tags.
11. Reduce the clamp opening and closing speed.
12. Slowly open the clamp to move the cavity plate away from the core plate.
13. Lock out and tag the machine and controller (if equipped).
14. Install the screws that secure the cavity plate to the cold deck and torque them to the specified value. Refer to the manufacturer's documentation for torque requirements.
15. Remove the leader pins through the installation in the cavity plate.
16. Remove all safety latch bars.
17. Check the electrical circuit with an ohmmeter to make sure no wires were damaged during installation. Refer to the electrical schematic to identify each zone.

6.5 Removing and Installing the Backing Plate

The following procedures describe how to remove and install the backing plate.

6.5.1 Removing the Backing Plate

To remove the backing plate, do the following:

NOTE:

The following procedure requires the use of an overhead lifting device. Refer to [Section 4.1](#) for lifting and handling instructions.

1. Remove the cold deck from the machine. Refer to [Section 4.3](#) for more information.
2. Remove the locating ring.

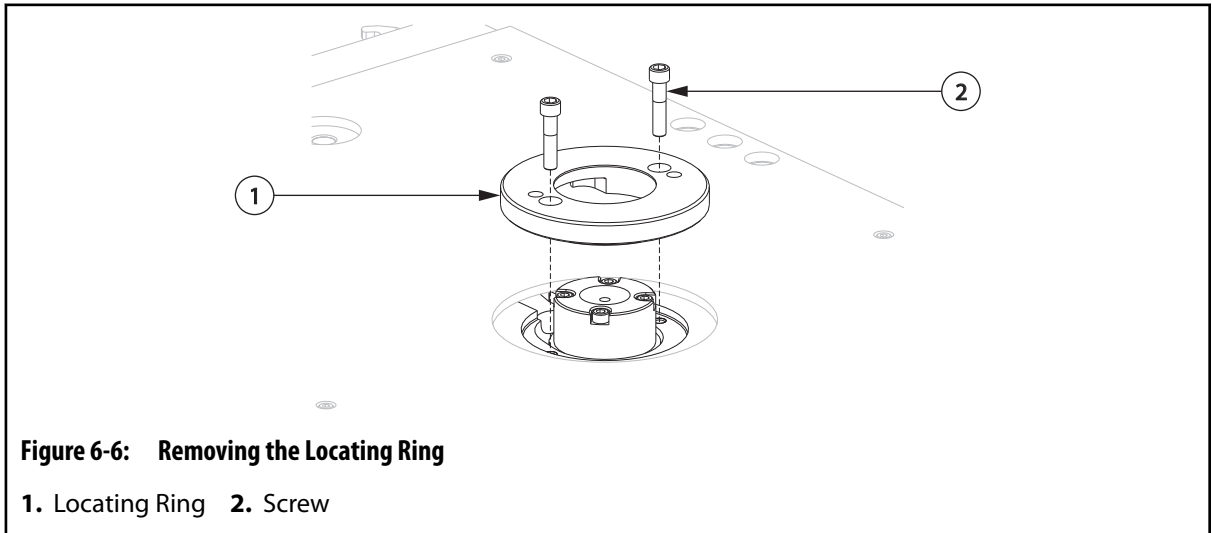

3. If the backing plate has wire grooves, do the following:
 - a. Disconnect the wires routed through the backing plate from the multi-pin connectors.
 - b. Remove the wires from the wire grooves.
4. Remove the screws that connect the backing plate to the manifold plate.

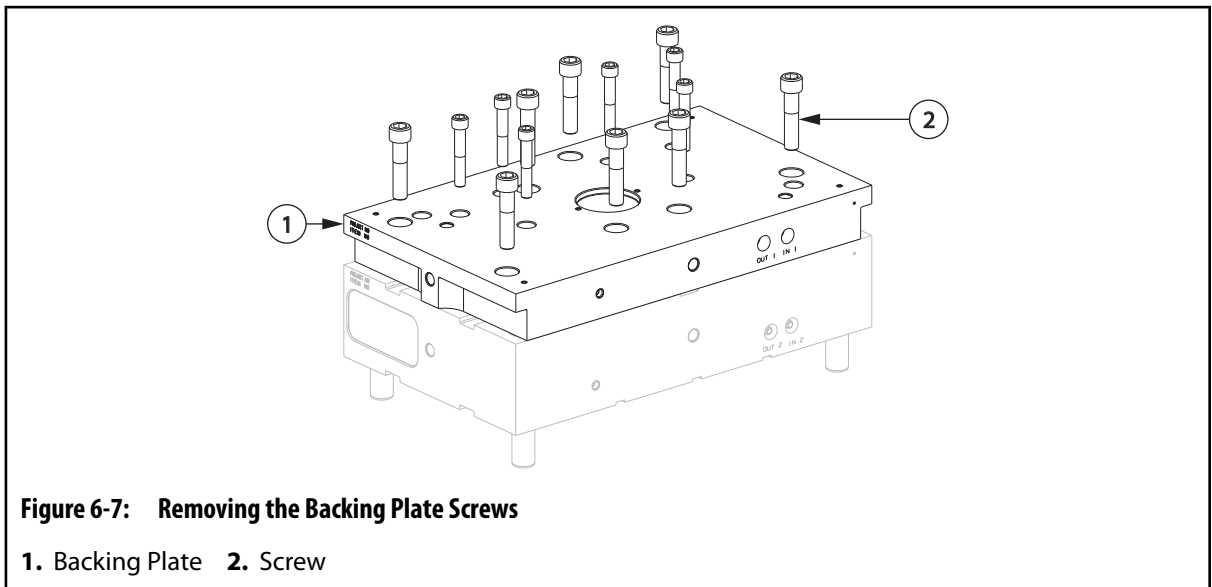

**WARNING!**

Crushing hazard – risk of death or serious injury. Inadequate lifting equipment could fail and cause death or serious injury. Make sure all lifting equipment is rated for the load and in safe operating condition.

5. Install hoist rings in the designated lifting points marked on the backing plate.
6. Attach an overhead lifting device to the hoist rings and lift the backing plate in stages. Use the pry slots between the manifold plate and backing plate to assist in separation.

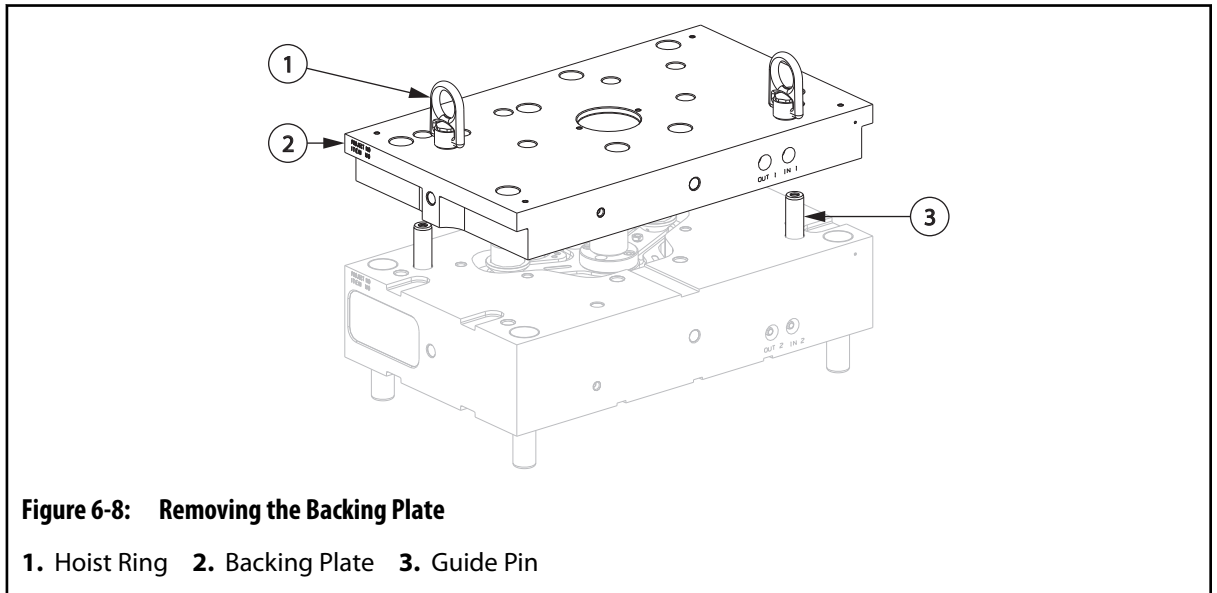

7. Moving the backing plate to a clean work area and set it on supports.

6.5.2 Installing the Backing Plate

To install the backing plate, do the following:

NOTE:

The following procedure requires the use of an overhead lifting device. Refer to [Section 4.1](#) for lifting and handling instructions.

1. Make sure the backing plate and manifold plate are clean and free of pry marks around the pry slots.
2. Clean the backing plate and manifold plate mounting surfaces with a medium India stone (240 grit oilstone) as needed.

**WARNING!**

Crushing hazard – risk of death or serious injury. Inadequate lifting equipment can fail and cause death or serious injury. Make sure all lifting equipment is rated for the load and in safe operating condition.

3. Install hoist rings in the designated lifting points marked on the backing plate.
4. Attach an overhead lifting device to the hoist rings and lift the backing plate.
5. Slowly lower the backing plate onto the manifold plate. Make sure the guide pins align with the backing plate locating bores.

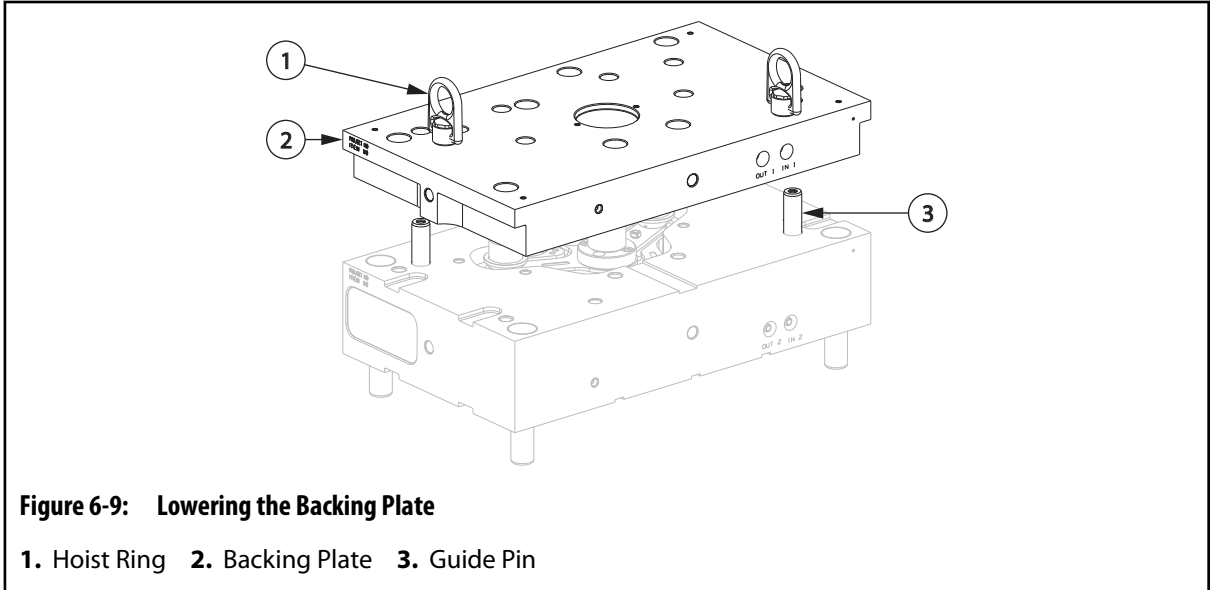

6. Disconnect the overhead lifting device and remove the hoist rings.
7. Install the screws that secure the backing plate to the manifold plate. Torque each screw to its specified value starting from the center and working outwards in a cross pattern. Refer to the assembly drawings for torque requirements.

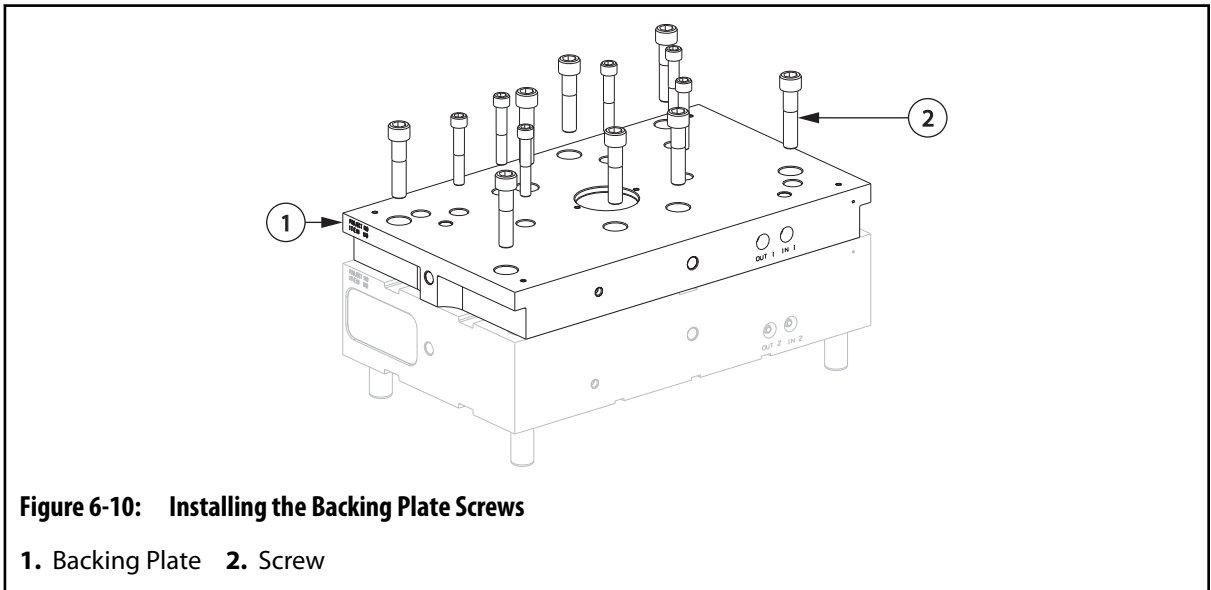

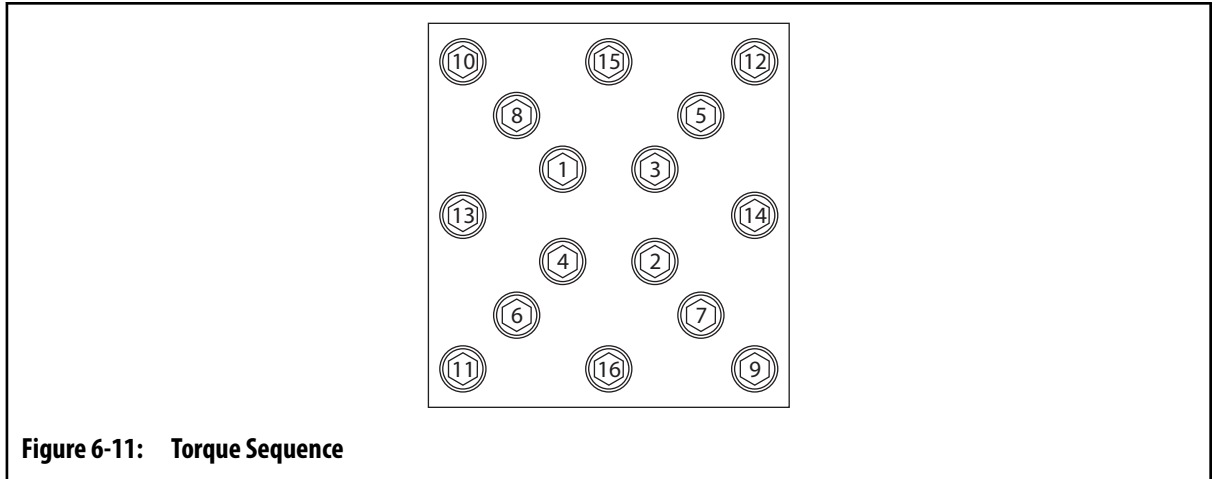

Figure 6-11: Torque Sequence

8. Install the locating ring.

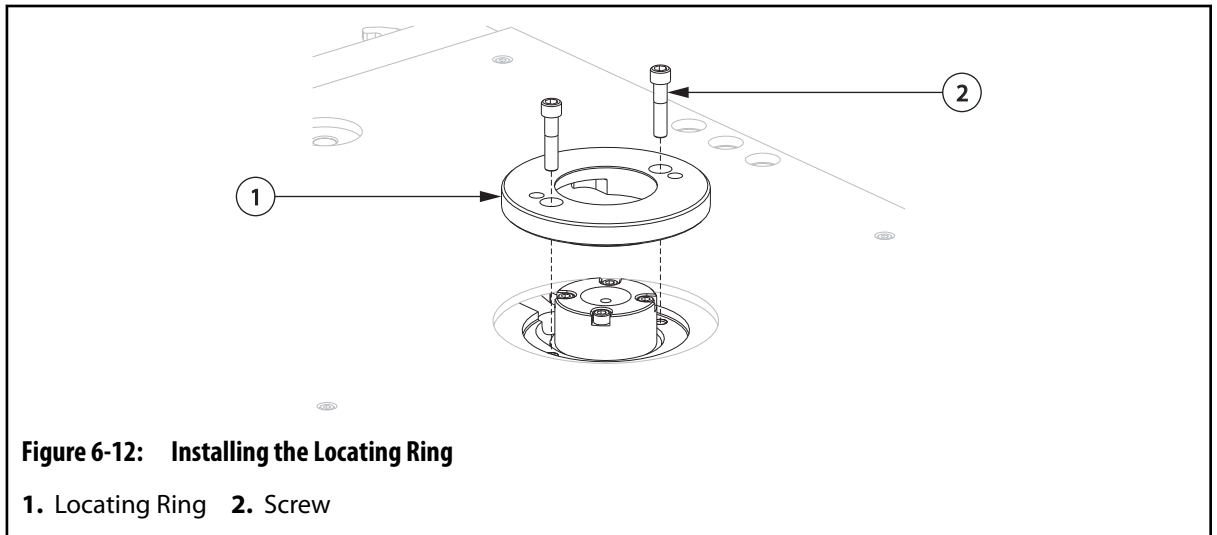

Figure 6-12: Installing the Locating Ring

1. Locating Ring
2. Screw

6.6 Removing and Installing Manifolds

The following procedures describe how to remove, maintain and install the manifolds.

6.6.1 Removing a Manifold

To remove a manifold, do the following:

NOTE:

The following procedure requires the use of an overhead lifting device. Refer to [Section 4.1](#) for lifting and handling instructions.

1. Remove the cold deck from the machine. Refer to [Section 4.3.2](#) for more information.
2. Remove the backing plate. Refer to [Section 6.5.1](#) for more information.

3. Remove the sprue bushing. Refer to [Section 6.13.1](#) for more information.
4. Remove the backup pads or cylinders.

For information about removing backup pads, refer to [Section 6.7.1](#).

5. Disconnect all thermocouple wires from the multi-pin connectors and wire channels.
6. Remove the screws that secure the manifold to the manifold plate.

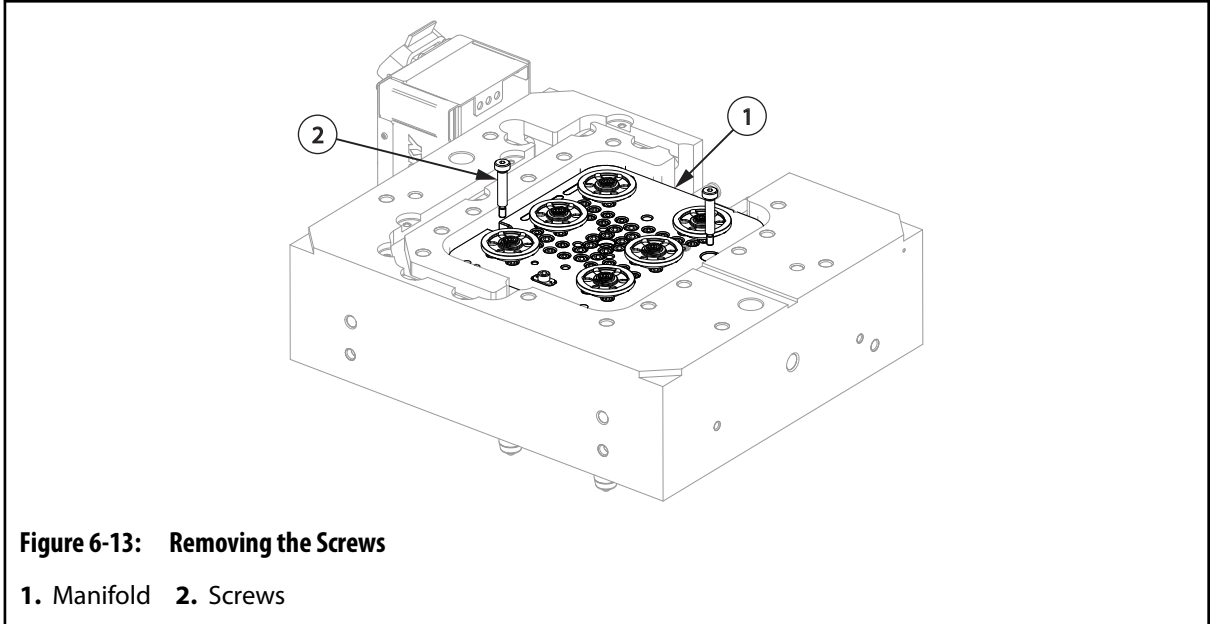

7. If the manifold has lifting points, do the following:

**WARNING!**

Crushing hazard – risk of death or serious injury. Inadequate lifting equipment can fail and could cause death or serious injury. Make sure all lifting equipment is rated for the load and in safe operating condition.

- a. Install hoist rings in the designated lifting points marked on the manifold.

- c. Re-Install the runner plugs and torque as requested value on the assembly print.

For bolted/split manifolds:

- a. Remove all bolts from the manifold.
- b. Pry the two halves.
- c. Pull out any cured LSR and clean the runners using a brass brush or a cloth.
- d. After cleaning has been completed, reassemble the manifold halves:
 - i. Check the condition of the O-rings on the manifold bushing and replace if necessary.
 - ii. Insert the two outermost manifold bushings into the bottom manifold half to align the assembly.
 - iii. Install top manifold half using the manifold bushing as alignment aid.
 - iv. Install the manifold bolts but don't torque them.
 - v. Insert remaining manifold bushings.
 - vi. Torque the manifold bolts to provided value from the assembly drawing.

6.6.3 Installing a Manifold

To install a manifold, do the following:

NOTE:

The following procedure requires the use of an overhead lifting device. Refer to [Section 4.1](#) for lifting and handling instructions.

1. Replace the manifold bushings as necessary. Refer to [Section 6.12](#) for more information.
2. Install the locating insulator, manifold locating dowel(s) and nozzle locating dowels into the manifold plate pocket.

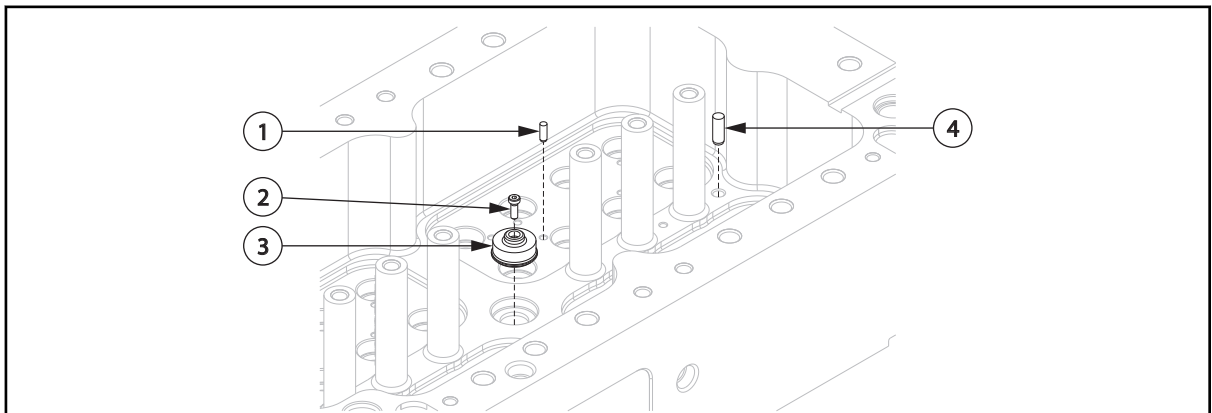

Figure 6-15: Assembling the Manifold Plate (Typical)

1. Nozzle Locating Dowel 2. Screw 3. Locating Insulator 4. Manifold Locating Dowel

3. If removed previously, install the nozzle housings in the manifold plate. Refer to [Section 6.11.3](#) for more information.
4. If the manifold has lifting points, do the following:

**WARNING!**

Crushing hazard – risk of death or serious injury. Inadequate lifting equipment can fail and could cause death or serious injury. Make sure all lifting equipment is rated for the load and in safe operating condition.

- a. Install hoist rings in the designated lifting points marked on the manifold.

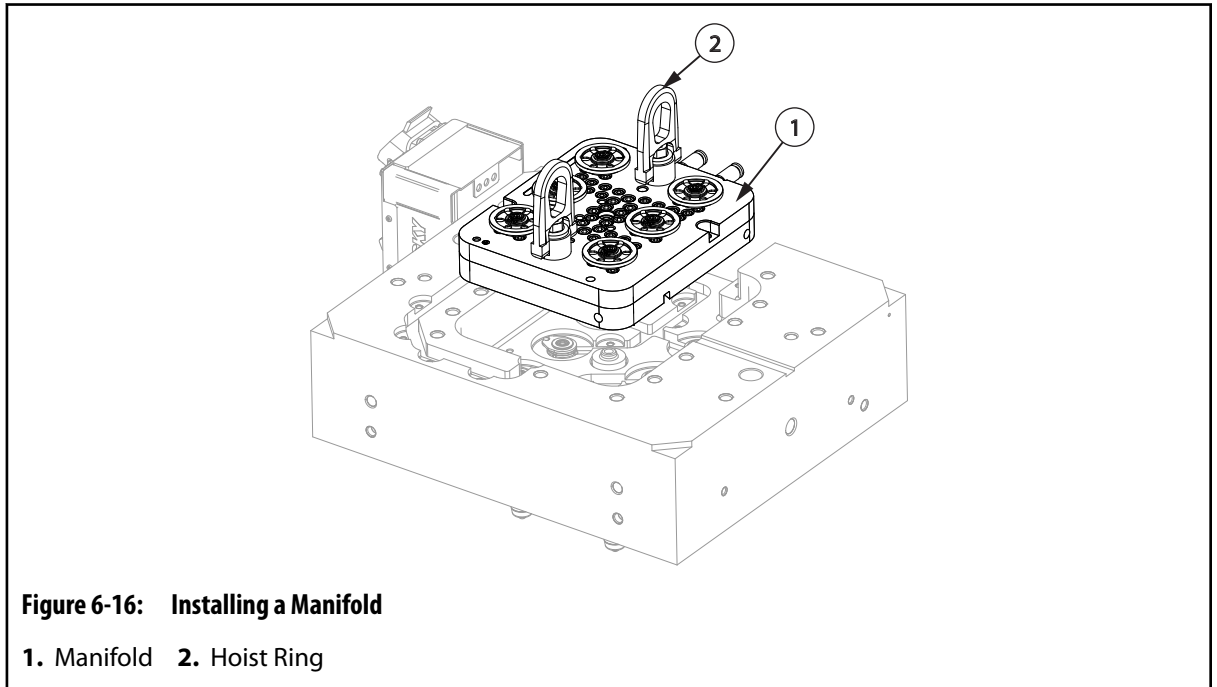

Figure 6-16: Installing a Manifold

1. Manifold 2. Hoist Ring

- b. Attach an overhead lifting device to the hoist rings.
5. Lift the manifold over the manifold plate pocket.
6. Lower the manifold into position onto the locating insulator and locating dowel. Adjust the manifold to engage the locating features.
7. If hoist rings are installed, disconnect the overhead lifting device and remove the hoist rings.

CAUTION!

Mechanical hazard – risk of damage to the cold deck. Screws used to secure the manifolds must remain loose until the preload is measured. Over-tightening the screws could over-extend the nozzle housings or damage components under the manifold that are not properly seated.

8. Install and hand tighten the socket head shoulder screw screws. Do not apply torque.

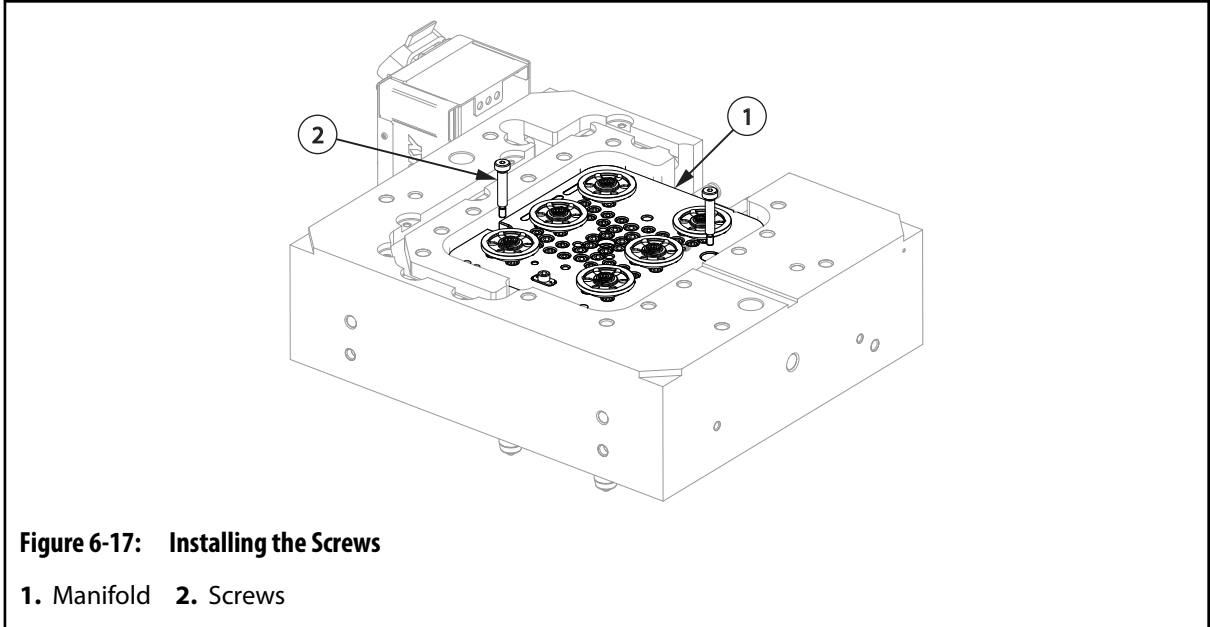

9. Measure the preload for the manifold. Refer to [Section 6.3](#) for more information.
10. Route the thermocouple wires through the exit channels at the top of the manifold plate.
11. Label the wire with the manifold zone number.
12. Crimp the wire ends and connect the wires to the appropriate multi-pin connectors. Refer to the electrical schematic for more information.
13. Install the backup pads or cylinders on the manifold.
 For information about installing backup pads, refer to [Section 6.7.2](#).
14. If equipped, install the sprue bushing. Refer to [Section 6.13.2](#) for more information.
15. Install the backing plate. Refer to [Section 6.5.2](#) for more information.
16. Install the cold deck in the machine. Refer to [Section 4.3.1](#) for more information.

6.7 Removing and Installing Backup Pads

The following procedures describe how to remove and install the backup pads from the manifold. Backup pads are specific to cold decks.

6.7.1 Removing the Backup Pads

To remove the backup pads, do the following:

1. Remove the cold deck from the machine. Refer to [Section 4.3.2](#) for more information.
2. Remove the backing plate. Refer to [Section 6.5](#) for more information.
3. Remove the valve stem assemblies. Refer to [Section 6.8](#) for more information.
4. For each backup pad, do the following:
 - a. Remove the clip ring.

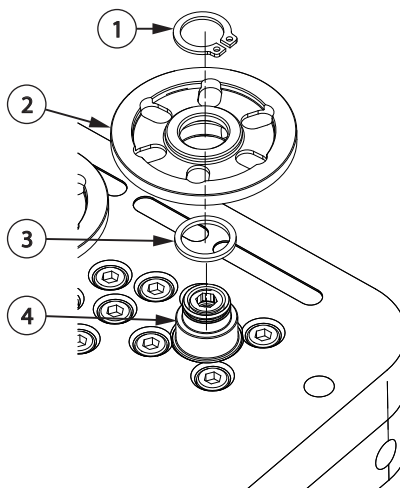

Figure 6-18: Backup Pad Assembly

1. Clip Ring 2. Backup Pad 3. Grafoil Seal 4. Manifold Bushing

- b. Install the backup pad removal tool by aligning the screw with the manifold bushing and installing the pull posts. Refer to [Section 1.10](#) for a list of special Husky tools and order numbers.

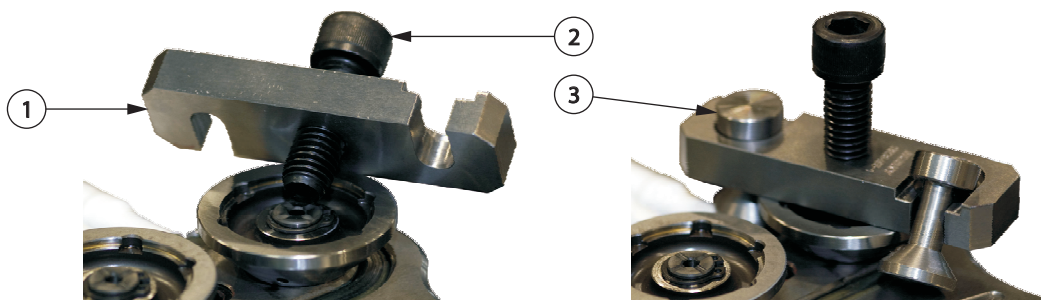

Figure 6-19: Aligning the Backup Pad Removal Tool

1. Spacer Bar 2. Screw 3. Pull Post

- c. Turn the screw on the backup pad removal tool clockwise to remove the backup pad.
- d. Discard the C-ring seals and Grafoil seal.
- e. Remove any resin deposits inside the backup pad.

6.7.2 Installing the Backup Pads

To install the backup pads, do the following:

1. For each backup pad, do the following:
 - a. Install new interior and exterior C-ring seals over the manifold bushing.

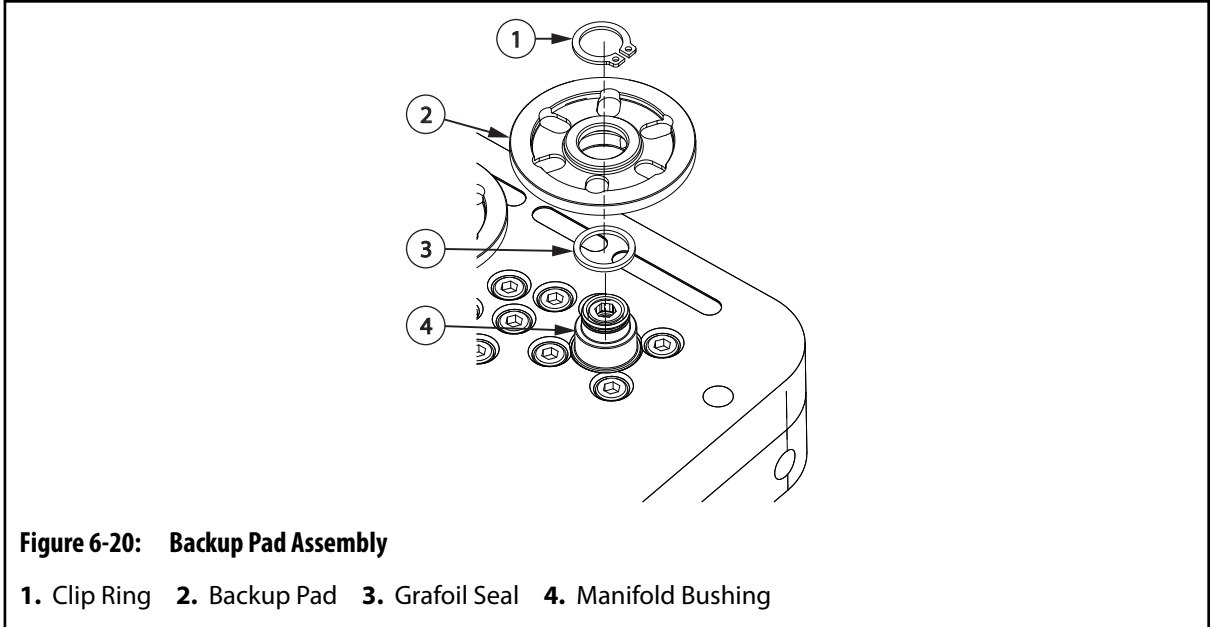

- b.** Install a new Grafoil seal over the manifold bushing.
 - c.** Install the backup pad. Make sure the backup pad contacts the metal O-ring seal.
 - d.** Install the clip ring.
- 2.** Measure the preload for the manifold. Refer to [Section 6.3](#) for more information.
 - 3.** Install the valve stem assemblies. Refer to [Section 6.8.2](#) for more information.
 - 4.** Install the backing plate. Refer to [Section 6.5.2](#) for more information.
 - 5.** Install the cold deck in the machine. Refer to [Section 4.3.1](#) for more information.

6.8 Removing and Installing Valve Stems

The following procedures describe how to remove and install the valve stems.

6.8.1 Removing the Valve Stems

Valve stems can be removed when the cold deck is cold or hot, with each method offering its own advantages and disadvantages.

Cold		Hot	
Advantage	Disadvantage	Advantage	Disadvantage
<ul style="list-style-type: none"> Fast removal reduces down time Easy to clean 	<ul style="list-style-type: none"> More difficult to remove valve stem Entire System need to get cleaned to remove cured liquid silicone rubber 	<ul style="list-style-type: none"> Valve stems are easy to remove 	<ul style="list-style-type: none"> Slow, increased down time Difficult to clean

To remove valve stems from the cold deck, do the following:

NOTE:

This procedure can be performed in the machine or on a work bench.

1. Remove the backing plate. Refer to [Section 6.5.1](#) for more information.
2. For each valve stem to be removed, do the following:
 - a. Remove the piston cylinder from the piston.

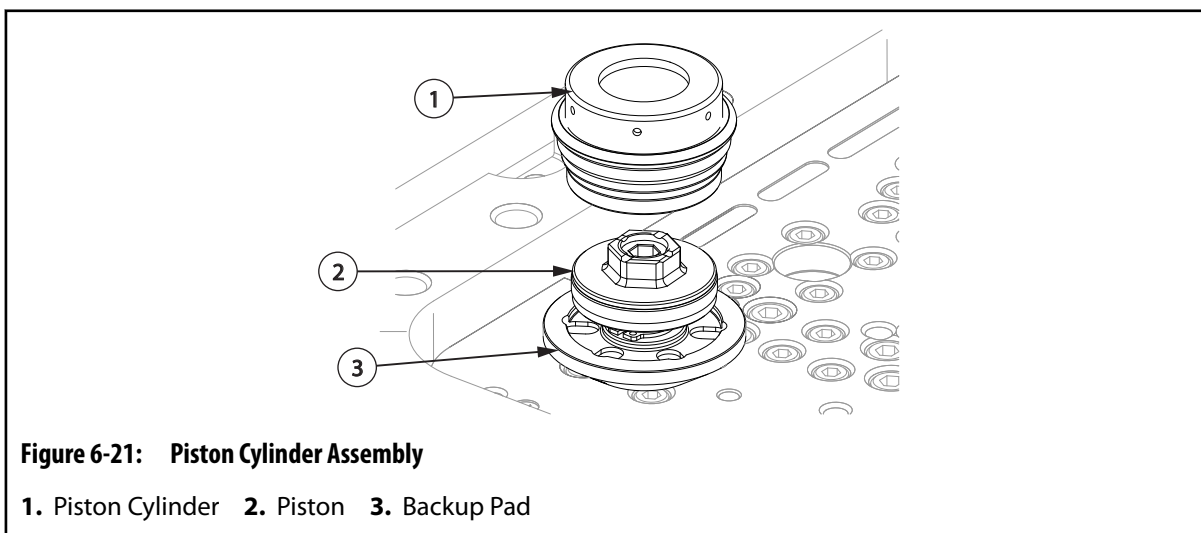

- b. From the valve stem removal tool assembly, connect the interface tool to the piston.

NOTE:

Refer to [Section 1.10](#) for a list of special tools and part numbers.

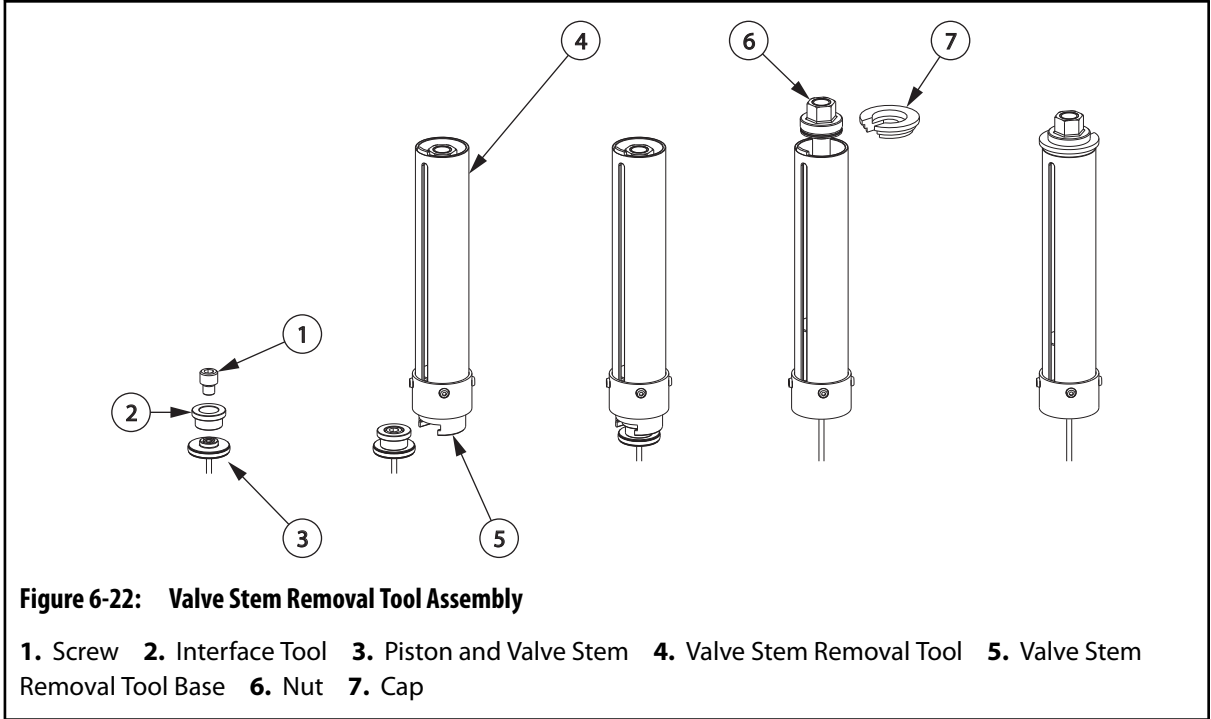

Figure 6-22: Valve Stem Removal Tool Assembly

1. Screw **2.** Interface Tool **3.** Piston and Valve Stem **4.** Valve Stem Removal Tool **5.** Valve Stem Removal Tool Base **6.** Nut **7.** Cap

- c. Slide the valve stem removal tool base onto the interface tool.
- d. Lower the sleeve and insert the cap beneath the thrust washers.
- e. Hold the valve stem removal tool in place and rotate the top nut clockwise until it is tight.

CAUTION!

Mechanical hazard – risk of damage to the equipment. Be careful not to bend the valve stem when removing it. Bent valve stems cannot be re-used.

- f. Using a wrench, rotate the nut on the valve stem removal tool clockwise to remove the valve stem assembly.

NOTE:

Double delta seals must be replaced during the installation of the valve stem assemblies. Do not remove them at this time.

- g. Remove the set screw and valve stem from the piston.

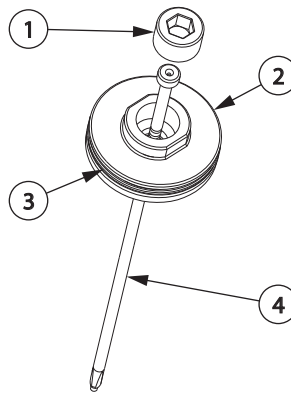

Figure 6-23: Valve Stem Assembly

1. Set Screw 2. Piston 3. Double Delta Seal 4. Valve Stem

3. Inspect the gate end of the valve stems to make sure there is no damage or wear. If possible, use a new valve stem for comparison.

CAUTION!

Mechanical hazard – risk of damage to the equipment. Abrasives should never be used to clean the valve stems, as this could damage the critical sealing surfaces.

4. Remove any liquid silicone rubber deposits from the valve stems.
5. Make sure the valve stems are not scratched, scored, bent or worn. Replace each valve stem if it shows signs of this type of damage.

6.8.2 Installing the Valve Stems

To install valve stems into the cold deck, do the following:

NOTE:

This procedure can be performed in the machine or on a work bench.

1. For each valve stem assembly, do the following:
 - a. Make sure all components are clean and free of liquid silicone rubber, scratches, nicks or burrs. Replace as necessary.

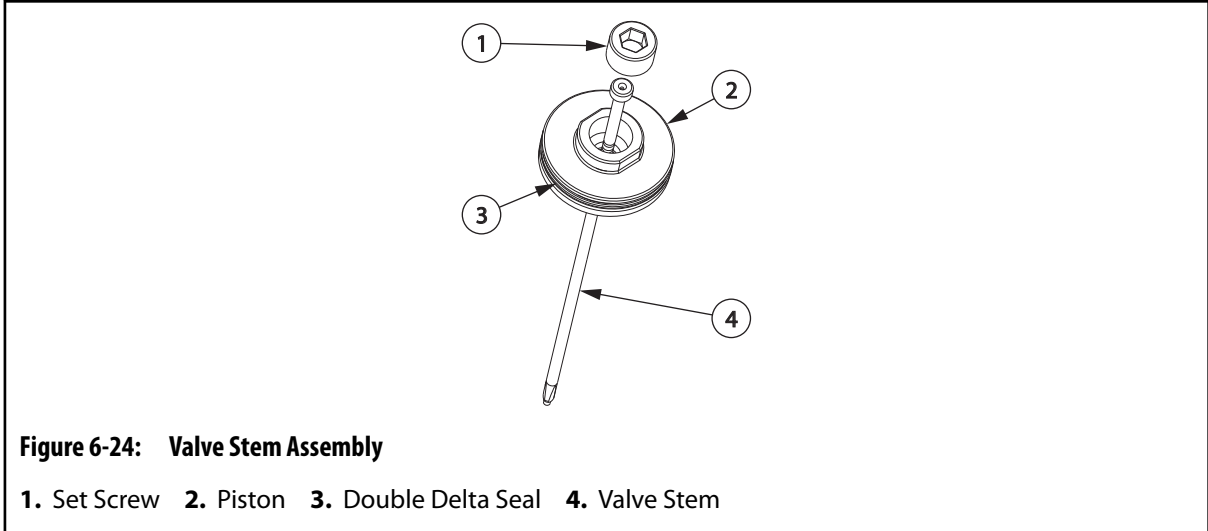

- b. Insert the valve stem through the piston.
 - c. Apply a static application grease to the threads of the set screw. Refer to [Section 3.5](#) for a list of recommended lubricants.
 - d. Install the set screw into the piston and hand tighten.
 - e. While holding the piston with a wrench or vice, torque the set screw to the specified value. Refer to the assembly drawings for torque values.
 - f. Rotate the valve stem to make sure no binding has occurred. The valve stem should rotate freely.
 - g. Replace the double delta seals and install the piston cylinder. Refer to [Section 6.9](#) for more information.
2. Carefully insert the valve stem assemblies into the manifold(s). Make sure the piston cylinders are fully seated in the backup pads.
 3. Install the backing plate. Refer to [Section 6.5.2](#) for more information.

6.9 Replacing the Double Delta Seals

To replace the double delta seals on the pistons, do the following:

1. Remove the backing plate. Refer to [Section 6.5](#) for more information.
2. Remove the valve stem assemblies. Refer to [Section 6.8](#) for more information.
3. For each valve stem assembly that requires new double delta seals, do the following:
 - a. Remove, clean and inspect the piston cylinder. If the piston cylinder is damaged, replace it immediately.

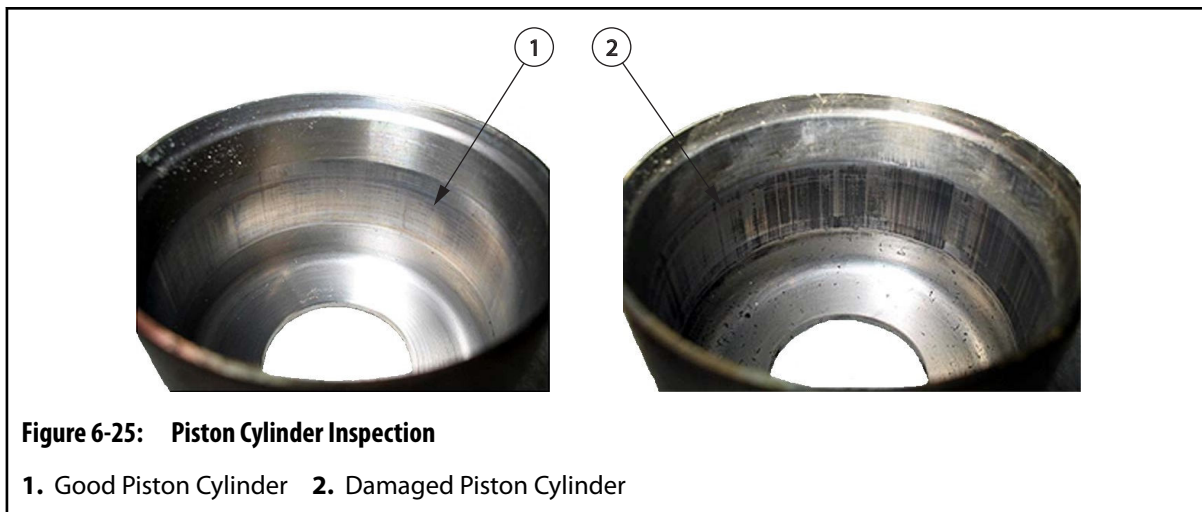
**CAUTION!**

Mechanical hazard – risk of damage to the equipment. Do not damage the pistons when removing the seals. This will later diminish the integrity of the new seals.

- b. Remove the outer and inner seals from the piston.

**IMPORTANT!**

Pistons must be cleaned before new seals are installed. Any debris or grease present will shorten the service life of the seals.

- c. Remove any loose debris or grease from the piston and surrounding area.
- d. Install the interior O-ring seal into the seal groove by rolling it over the piston. No tools are required.

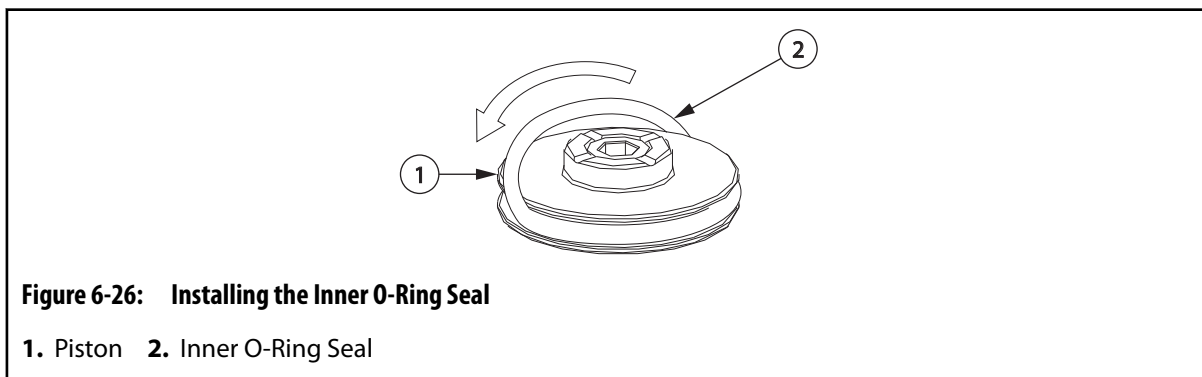

- e. Place the seal installation tool on top of the piston.

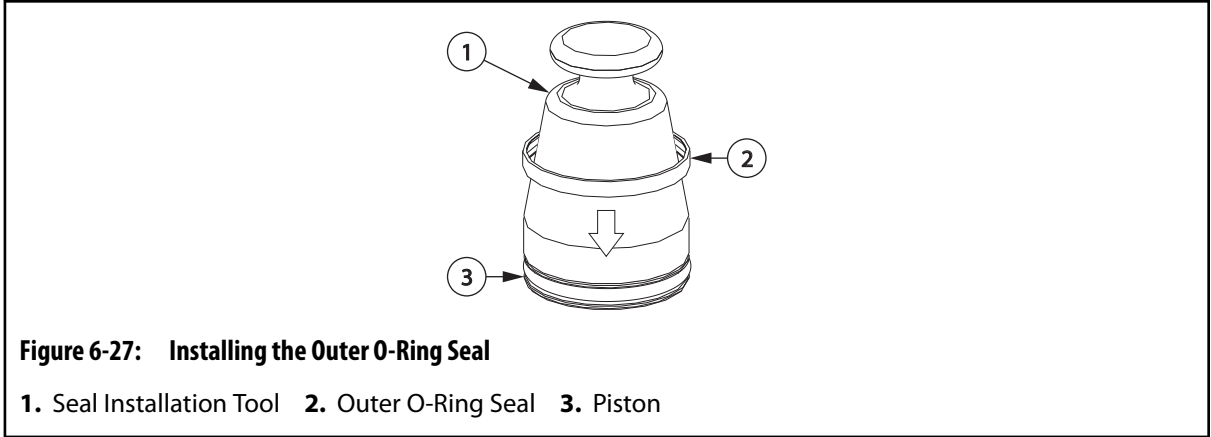

- f. Install the outer O-ring seal by pushing the seal over the seal installation tool until it sits over the interior O-ring seal.
- g. Remove the seal installation tool.
- h. Slide the piston installation tool over the piston to compress the seals. This will protect the seals from damage when the piston cylinder is installed.
- i. Inspect the piston assembly for damage, debris or grease.

NOTE:

The piston cylinder is easier to install when it is installed shortly after the piston installation tool is removed.

- j. Install the piston cylinder.
- 4. Install the valve stem assemblies. Refer to [Section 6.8](#) for more information.
- 5. Install the backing plate. Refer to [Section 6.5](#) for more information.

6.10 Removing and Installing Nozzle Tips

The following procedures describe how to remove and install nozzle tips.

NOTE:

When removing the nozzle tips, it is recommended they be removed when the Tip Temperature is at room temperature (< 25 °C or < 77 °F).

6.10.1 Removing the Nozzle Tips

To remove the nozzle tips do the following:

- 1. Separate or remove the cavity plate from the cold deck. Refer to [Section 6.4](#) for more information.

CAUTION!

Mechanical hazard – risk of damage to the cold deck. Solidified LSR can make it difficult to loosen the nozzle tips.

2. Nozzle tip retainer should be loosened and removed by hand.
3. Nozzle tip can be pulled out by hand.

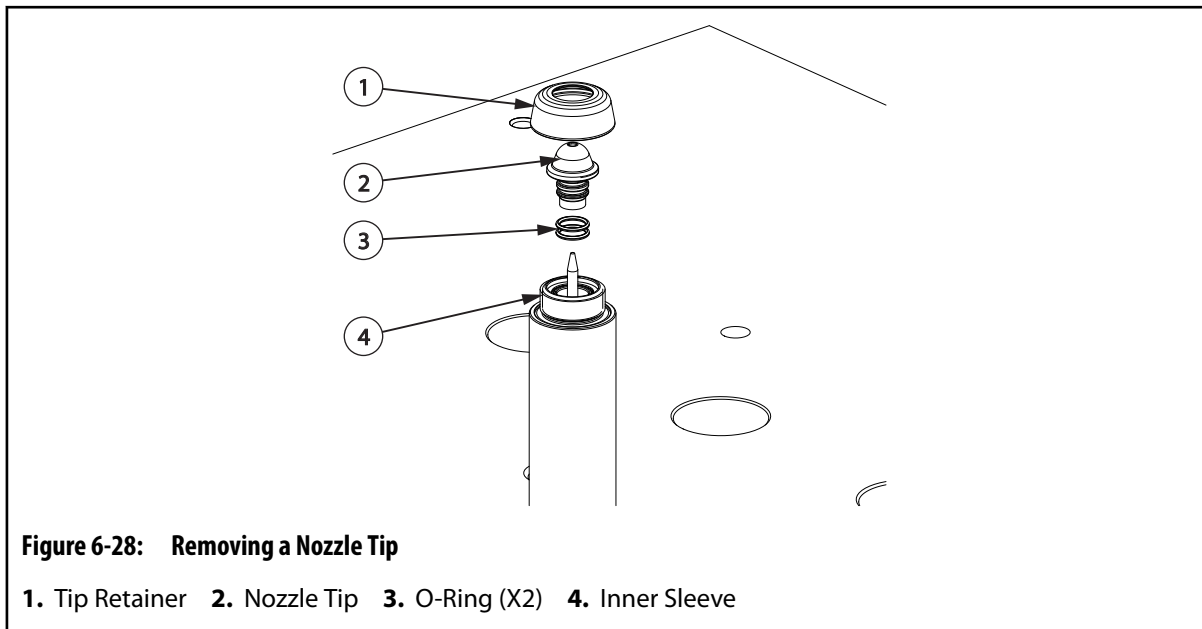
**IMPORTANT!**

Care must be taken to prevent damage to the nozzle tip and nozzle sealing surfaces

4. Remove any LSR from the interior and exterior of the nozzle tip using a soft wire brush or equivalent.
5. Remove any LSR from the interior and exterior of the nozzle housing using a soft wire brush or equivalent.

NOTE:

Do not remove locks and tags until the nozzle tips are installed.

6.10.2 Installing the Nozzle Tips

To install a nozzle tip, do the following:

1. Lock out and tag the machine and controller (if equipped). Refer to [Section 2.5](#) for more information.



IMPORTANT!

If LSR or other residues are not thoroughly cleaned off the threads and seating areas of both the nozzle tip and nozzle housing, the result could lead to the following:

- Poor performance or quality of the gate due to the incorrect tip position (too far back)
- Leakage between the nozzle tip and the gate

2. Remove any LSR or other residue found on the nozzle tips and nozzle housings.
3. Clean the nozzle tip sealing surface of the nozzle housing bore with a soft wire brush.
4. Make sure the nozzle tip and nozzle housing are clean and dry.
5. Place the wave spring and the O-rings on the tip.
6. Engage the tip with the nozzle housing and screw the tip-retainer hand-tight onto the nozzle.

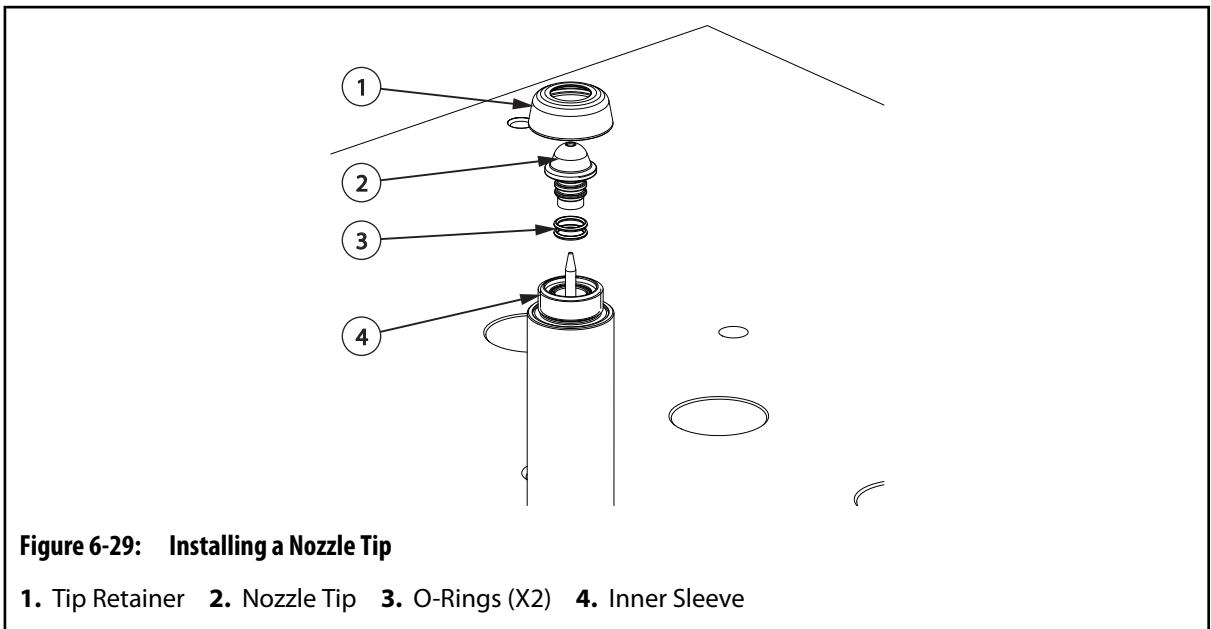

7. Measure the height of the nozzle tip using a depth micrometer and compare the measurement to the tip height listed on the Tip Chart in the assembly drawings.
8. If the nozzle tip height is outside the tolerances listed on the Tip Chart, refer to [Section 6.10.3](#).

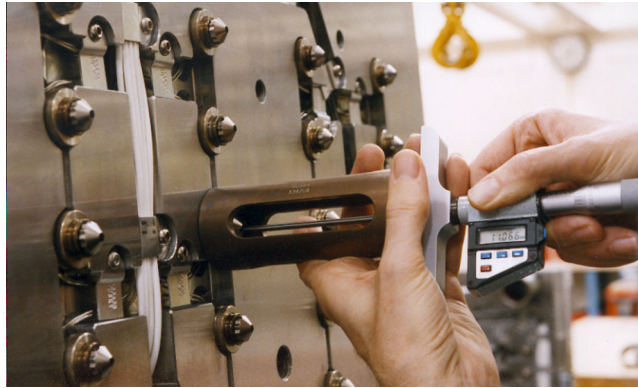

Figure 6-30: Measuring the Nozzle Tip Height

9. Remove all locks and tags.
10. Install the cavity plate. Refer to [Section 6.4](#) for more information.

6.10.3 Troubleshooting Nozzle Tip Heights

The following describes reasons and corrective action for nozzle heights that are less or more than the values listed on the Tip Chart.

Problem	Reason	Action
Dimension is shorter than required tip height	Nozzle tip is not in contact with tip retainer, issue might be some dirt between the components	<ol style="list-style-type: none"> 1. Remove the nozzle tip retainer. 2. Clean LSR from the nozzle tip and tip retainer.
Dimension is longer than required tip height	Nozzle tip retainer is not correctly installed	<ol style="list-style-type: none"> 1. Remove the nozzle tip retainer 2. Make sure the tip retainer and corresponding inner sleeve threads are clean and not damaged. If the inner sleeve is damaged, component need to be exchanged.

6.11 Removing and Installing Nozzle Housings

The following procedures describe how to remove, maintain and install nozzle housings.

6.11.1 Removing Nozzle Housings

To remove a nozzle housing, do the following:

1. Remove the cold deck from the machine. Refer to [Section 4.3](#) for more information.

2. Remove the cavity plate. Refer to [Section 6.4](#) for more information.
3. Remove the backing plate. Refer to [Section 6.5](#) for more information.
4. Remove the manifold. Refer to [Section 6.6](#) for more information.
5. Pull the nozzle stack assembly out of the manifold pocket and disassemble.

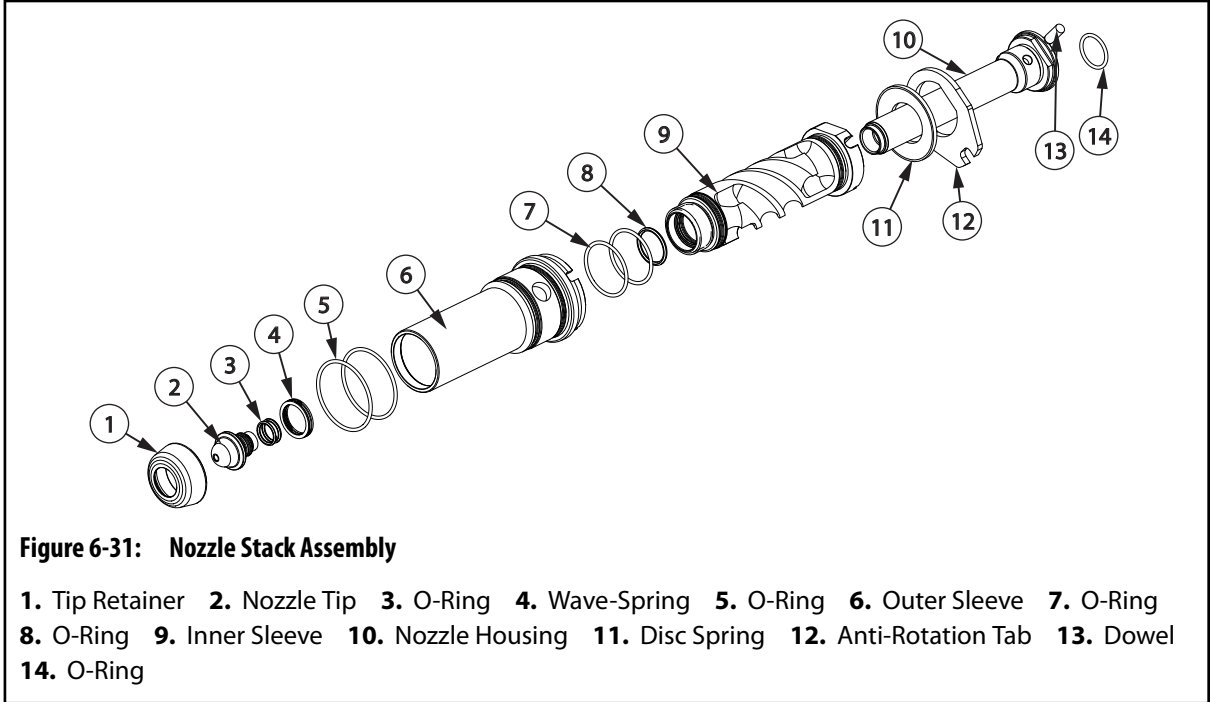

6. Inspect and clean the nozzle housing. Refer to [Section 6.11.2](#) for more information.

6.11.2 Inspecting and Cleaning Nozzle Housings

To inspect and clean the nozzle housings after they have been removed, do the following:

CAUTION!

Mechanical hazard – risk of equipment damage. Do not hone the back surface of the nozzle housing to remove nicks and burrs. The back surface is a precision made section of the housing. Honing this section will cause the system to leak and void the leak proof guarantee for the cold deck.

1. Inspect all nozzle stack components for damage or wear. Replace as necessary.
2. Remove all LSR from the melt channel in the nozzle housing.
3. Remove all LSR from the nozzle housing bore in the manifold plate.

6.11.3 Installing the Nozzle Housings

To install the nozzle housings, do the following:

1. Assemble each nozzle housing.

NOTE:

Refer to the assembly drawings to verify the orientation and correct number of Ultra springs.

**IMPORTANT!**

Make sure that the tip of the thermocouple is pressed all the way down into the hole in the nozzle housing .

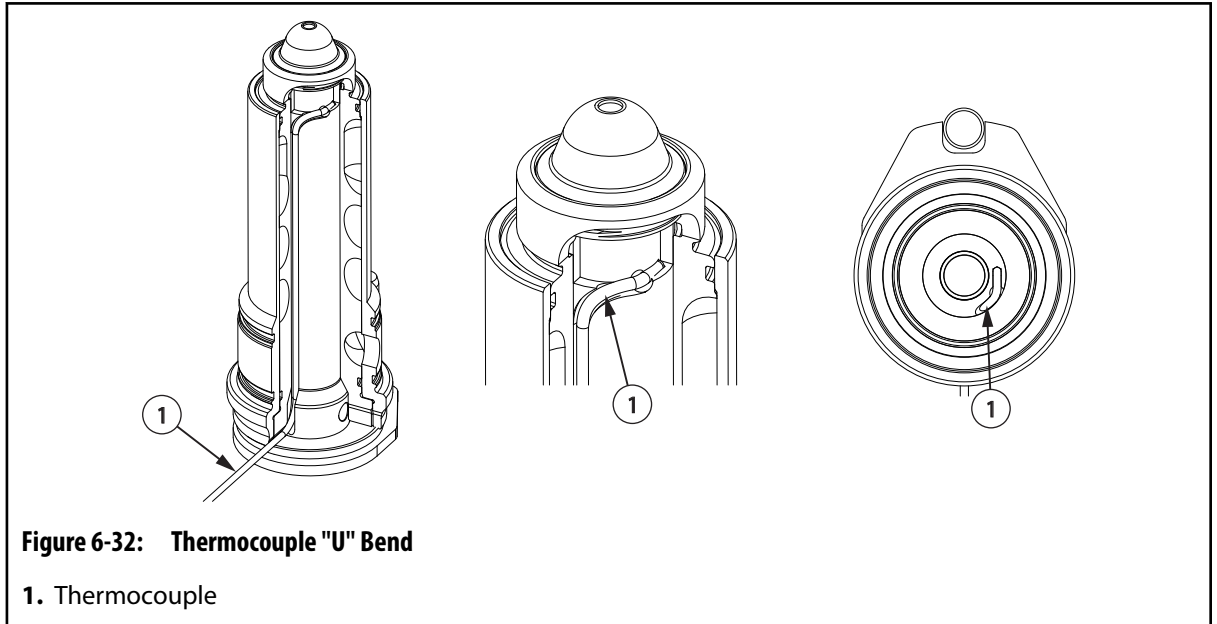

Figure 6-32: Thermocouple "U" Bend

1. Thermocouple
2. Bend the thermocouple so it is tight to the nozzle housing body.
3. Inner sleeve will support the thermocouple in position when assembled.
4. Place all housing assemblies into the nozzle bores in the manifold plate. Make sure the housing assemblies are properly aligned with the nozzle locating dowels to prevent rotation.
5. Route the nozzle thermocouple wires through the wire channels in the manifold plate.
6. Make sure all wiring is properly retained in the wire channels using wire clips.
7. Make sure to stagger the knuckles in the wire grooves.



Figure 6-33: Staggering the Knuckles in the Wire Grooves

8. Label each wire with the nozzle zone number. Refer to the electrical schematic for the zone number.
9. Crimp the wire ends and connect the wires to the appropriate multi-pin connectors. Refer to the electrical schematic for more information.
10. Test each thermocouple .

11. Install the manifold. Refer to [Section 6.6](#) for more information.
12. Install the backing plate. Refer to [Section 6.5](#) for more information.
13. Install the cavity plate. Refer to [Section 6.4](#) for more information.
14. Install the cold deck into the machine. Refer to [Section 4.3](#) for more information.

6.12 Removing and Installing Manifold Bushings

The following procedures describe how to remove, maintain and install manifold bushings.

Manifold bushings need to be replaced if the following occurs:

- The valve stem is stuck and cannot be removed
- The air seal face is damaged
- The manifold bushing is damaged in a way that renders it unusable

6.12.1 Removing Liquid Silicone Rubber Manifold Bushings

To remove manifold bushings for liquid silicone rubber systems, do the following:

1. Disconnect the thermocouple wires from the manifolds.
2. Remove the manifold from the manifold plate pocket. Refer to [Section 6.6](#) for more information.
3. Gently press the manifold bushings out of the manifold using a light brass punch. Take care not to damage the bushings or manifold.

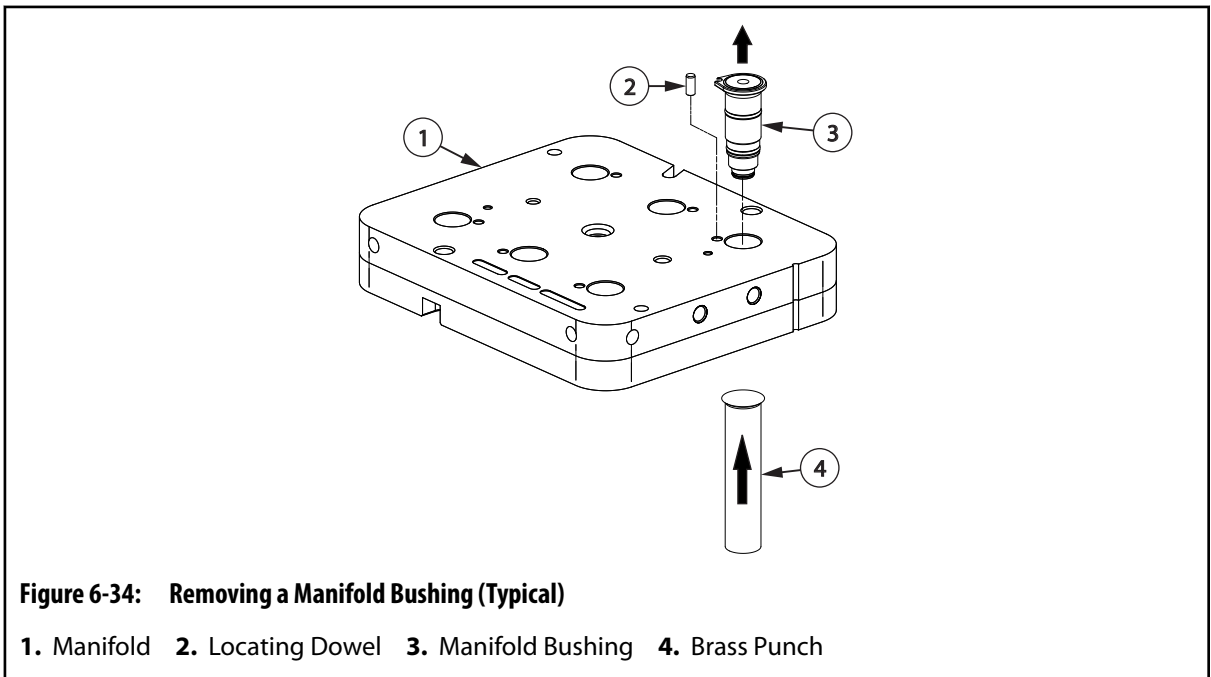

6.12.2 Installing Liquid Silicone Rubber Manifold Bushings

To install manifold bushings for liquid silicone rubber systems, do the following:

1. Remove any liquid silicone rubber from the manifold bushing pockets and seating area in the manifold using brass scrapers. Do not damage the sharp corners or sealing surfaces.
2. Remove any liquid silicone rubber from the exterior of the manifold bushings with brass scrapers. Do not damage the sharp corners or sealing surfaces.
3. Make sure the interior of the manifold bushing is free of liquid silicone rubber.
4. Check that all contact surfaces on the manifold and manifold bushings are clean and free of residue, scratches, nicks, or burrs.
5. Make sure the manifold bushing locating dowel is installed in the manifold.
6. Make sure the O-rings are in good condition and are installed on the manifold bushing, if needed, replace O-rings.
7. Install the manifold bushing into the manifold and orient it by aligning the alignment slot on the manifold bushing with the locating dowel.

6.12.3 Installing Bushing Insert Set Screw into the Liquid Silicone Rubber Manifold Bushings

To install bushing inserts and O-rings into the manifold bushings for liquid silicone rubber systems, do the following:

1. Remove any liquid silicone rubber from the manifold bushing and inserts all over internal and external seating areas using brass brush. Do not damage the sharp corners or sealing surfaces.
2. Make sure the interior of the manifold bushing is free of liquid silicone rubber.
3. Check all contact surfaces on the manifold bushing and inserts are clean and free of residue, scratches, nicks, or burrs.
4. Make sure O-rings in proper conditions are installed on the manifold bushing insert, if needed, replace the O-rings.
5. Install the insert into the manifold bushing and torque as specified on the assembly drawing.
6. Install the set screw into the manifold bushing and apply necessary torque as specified on the assembly drawing.

6.13 Removing and Installing the Sprue Bushing

The following procedures describe how to remove, maintain and install the sprue bushing.

6.13.1 Removing the Sprue Bushing

To remove the sprue bushing, do the following:

1. Remove the cold deck from the machine. Refer to [Section 4.3](#) for more information.

2. Remove the backing plate. Refer to [Section 6.5](#) for more information.
3. Remove the screws that secure the sprue bushing to the manifold.

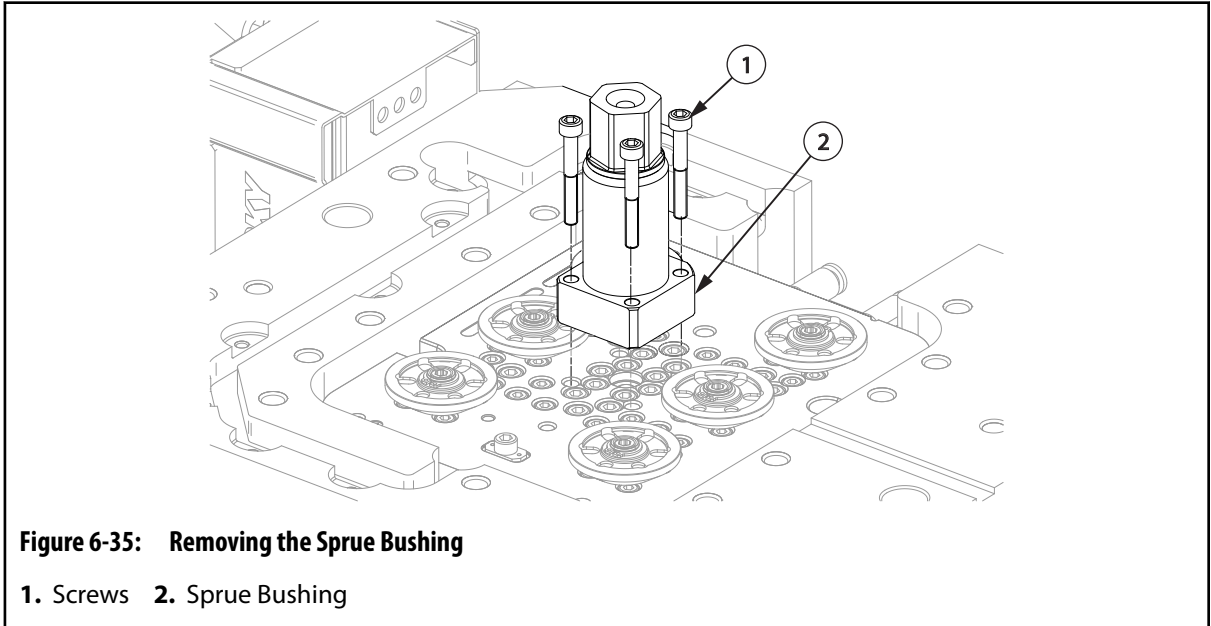

4. Remove the sprue bushing.
5. Using a brass rod or brush to remove the LSR slug from the sprue bushing melt channel. Clean the sprue bushing. Do not damage any sealing surfaces.
6. Check and repair the machine nozzle interface, if required.

6.13.2 Installing the Sprue Bushing

To install the sprue bushing, do the following:

NOTE:

The supplied screws used to install the sprue bushing are of a special quality and must not be substituted.

1. Clean the surfaces on the sprue bushing and manifold where the two components will interface.

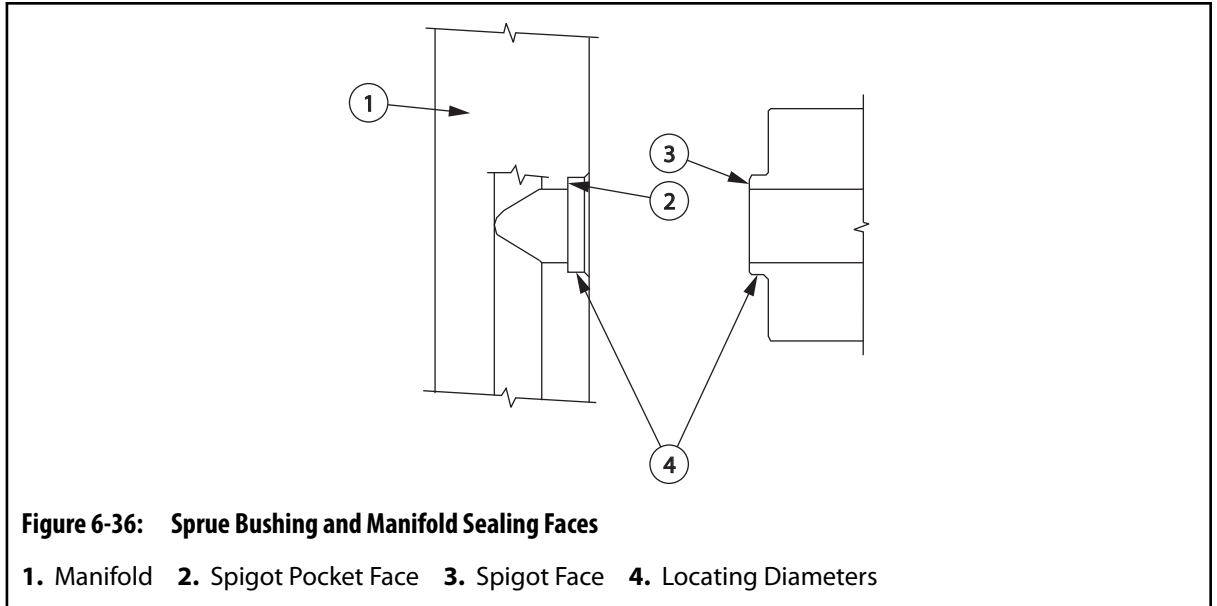

2. Apply a high temperature anti-seize lubricant to the screws used to install the sprue bushing. Refer to [Section 3.5](#) for information about recommended lubricants.

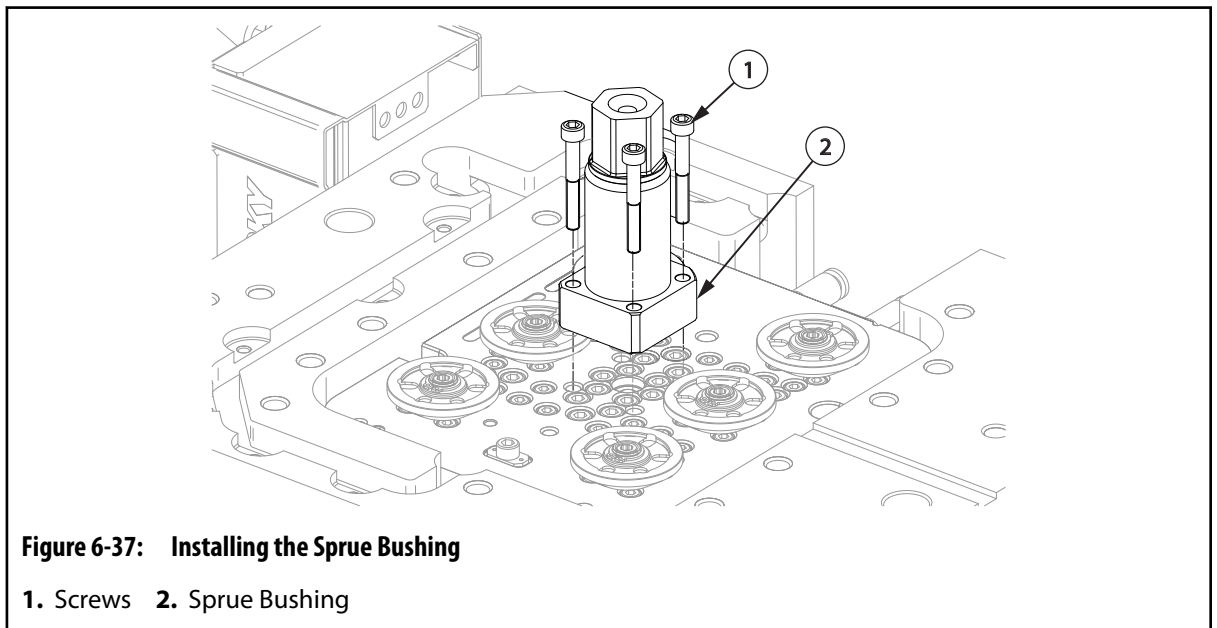

3. Install the sprue bushing and torque all screws to half the specified value in a cross pattern. Refer to the assembly drawings for torque requirements.
4. Torque the screws fully to the specified value to make sure an even seal is made between the sprue bushing and manifold. Refer to the assembly drawings for torque requirements.
5. Install the backing plate. Refer to [Section 6.5](#) for more information.
6. Install the cold deck into the machine. Refer to [Section 4.3](#) for more information.

6.14 Removing Air and Water Plugs



IMPORTANT!

Husky does not recommend the removal of seized air and water plugs in the field. Contact Husky to arrange returning the cold deck for repair and/or rework. This procedure was prepared by Husky at the request of the customer, and does not in any way absolve the customer from fulfilling their usual obligations, including those mentioned above. Husky disclaims liability for damage to property or injury to personnel caused by the customer attempting the procedure. It is the obligation of the customer to confirm that personnel are trained and have appropriate qualifications including: understanding the safe methods and using the correct personal protective equipment prior to performing this procedure.



WARNING!

Burn and mechanical hazard - risk of serious injury and/or damage to the equipment. Only qualified personnel should perform this procedure using the appropriate personal protective equipment.



WARNING!

Burn hazard – risk of serious injury. To avoid serious burns, do not touch the plate or plug after heating and wear personal protective equipment consisting of a heat-resistant coat, heat-resistant gloves, and a full face shield over safety glasses.

1. Heat the plate area surrounding the stainless steel plug with a hand held torch for 1-2 minutes. Do not heat the plug directly.



IMPORTANT!

Do not use an impact gun or impact driver as the plug will seize.

2. Once the plate is heated, use a safety-rated breaker bar and the appropriate Hex socket adapter to apply pressure and back the plug out.

If the plug does not move, repeat [step 1](#) and [step 2](#).

3. If the plug cannot be removed manually using [step 1](#) and [step 2](#), the use of a magnetic drill or milling out the plug will be required.

If you are unable to safely remove the plug as described in this procedure, return the part to Husky for rework and/or repair. Contact Husky for more information.

**IMPORTANT!**

Do not use an impact gun or impact driver as the plug will seize.

4. Clean the threads on the plug and then, if required, apply the appropriate plug sealant to the threads.
5. Install the new plug. Refer to [Table 6-1](#) for the recommended torque. Contact Husky for appropriate part number

Table 6-1: Pipe Threads, Taps and Torques

Pipe Thread †STAINLESS STEEL	Tap Drill	Torque
1 - 11 1/2	29.36 mm (1.156 in)	108 N·m (80 lbf·ft)
1 1/4 - 11 1/2	38.10 mm (1.50 in)	136 N·m (100 lbf·ft)
1 1/2 - 11 1/2	44.05 mm (1.734 in)	163 N·m (120 lbf·ft)
2 - 11 1/2	56.36 mm (6.35 in)	203 N·m (150 lbf·ft)
1/16 - 27	6.35 mm (0.250 in)	11 N·m (8 lbf·ft)
1/8 - 27	8.73 mm (0.344 in)	14 N·m (10 lbf·ft)
3/8 - 18	14.29 mm (0.563 in)	27 N·m (20 lbf·ft)
1/2 - 14	18.25 mm (0.718 in)	34 N·m (25 lbf·ft)
3/4 - 14	23.42 mm (0.922 in)	47 N·m (35 lbf·ft)

6. If you are unable to safely complete the steps in this procedure, return the part to Husky for rework and/or repair. Contact Husky for more information.

6.15 Removing Liquid Silicone Rubber from the Cold Deck

Occasionally, liquid silicone rubber may be left in the cold deck or a leakage of liquid silicone rubber may occur due to a component failure. The liquid silicone rubber will have to be removed at this point. However, removing the liquid silicone rubber without damaging components requires careful attention

The following procedures describe how to carefully remove liquid silicone rubber from the cold deck and its components.

6.15.1 Plate Cleaning and Inspection

The following procedure describes a general cleaning and inspection process for plates.



IMPORTANT!

The use of an open flame to remove LSR is not recommended due to the possible gases given off by some LSR and the risk of burns while working around hot LSR. In addition, there exists a potential for fire when using a torch to heat and melt LSR. The heat from the torch may also overheat and damage small components.

1. Using brass or hardwood scrapers, remove all resin deposits from the plates
2. Remove all cooling fittings and plugs.
3. Clean the deposits from the cooling hoses.

CAUTION!

Mechanical hazard – risk of equipment damage. Cleaning products such as scour pads and brushes can be abrasive. When using pads or brushes, do not damage surfaces. To avoid damaging surfaces, use non-abrasive products.

4. Clean the entire plate using a medium India stone (240 grit oilstone) on flat surfaces and Scotch-Brite™ No. 7447 (Maroon) on difficult to reach areas
5. Remove any deposits from the alignment bushings and alignment dowels.
6. Check the plate for the following:
 - Wear at the alignment bushings and alignment dowels
 - Corrosion in the cooling channels
 - Cracks (especially around the mold mounting bolt holes or clamp mounting slots)
 - Damage to the dowel holes
 - Sharp edges around the wire grooves



WARNING!

Respiratory hazard – risk of serious injury. Use an appropriate breathing apparatus as protection while using a brass wire bush or wheel. See the material safety data sheet (MSDS) from the liquid silicone rubber supplier. As a minimum, a particle mask is recommended.

7. Rework or replace the plates as required.

NOTE:

Before re-installing components, the plate pocket(s) must be thoroughly cleaned. An electric hand drill with a brass wire wheel or a brass chisel may be used. This will prevent unnecessary scratching.

8. Install the fittings with new pipe plugs.
9. Pressure test the cooling circuits to verify there are no coolant leaks.

**WARNING!**

Wear appropriate eye and face protection following the recommendations of the ABMA (American Brush Manufacturers Association) and ANSI (American National Standards Institute) following ANSI Z87.1 "Occupational Eye and Face Protection" ANSI B165.1 and ANSI B165.2 "Safety Requirements - Power Brushes".

**WARNING!**

Respiratory hazard – risk of serious injury. Use an appropriate breathing apparatus as protection while using a brass wire brush or wheel. See the material safety data sheet (MSDS) from the LSR supplier. As a minimum, a particle mask is recommended.

10. Brush the plate surfaces with a brass wire brush and collect any dust with a vacuum.

CAUTION!

Mechanical hazard – risk of equipment damage. Cleaning products such as scour pads and brushes can be abrasive. When using pads or brushes, do not damage, scratch, or score any sealing surfaces. To avoid damaging sealing surfaces, use non-abrasive products.

11. Clean the plate with Scotch-Brite No. 7447 (Maroon).

6.16 Removing Liquid Silicone Rubber from the Manifold Plate

Excess LSR can weep out of the valve stem area into the manifold plate during production. This can inhibit valve stem performance.

CAUTION!

Mechanical hazard – risk of damage to the cold deck. Weepage must be cleaned before it completely fills the back side of the manifold pocket or covers any electrical wiring.

**IMPORTANT!**

Do not extend the cleaning interval beyond the interval recommended in the maintenance schedule. If the rate of weepage increases significantly, valve stem and manifold bushing sealing components should be inspected for wear and replaced, if needed.

The manifold plate should be cleaned at the interval specified in the maintenance schedule. However, based on observations made during an inspection, an earlier interval may be required.

To remove LSR from the manifold plate, do the following:

1. Remove the cold deck from the machine. Refer to [Section 4.3](#) for more information.

2. Remove the backing plate. Refer to [Section 6.5](#) for more information.
3. Remove the valve stem assemblies. Refer to [Section 6.8](#) for more information.
4. Remove the backup pads or cylinders from the manifold. Refer to [Section 6.7](#) for information about removing backup pads.

**WARNING!**

Burn, fire and gas hazard – risk of death or serious injury, and property damage. Use of an open flame to remove LSR can produce harmful gases (depending on the LSR type), damage components and increase the risk of fire. Only use open flames sparingly and in a controlled environment.

**WARNING!**

Burn hazard – risk of serious injury. To avoid serious burns, wear personal protective equipment consisting of a heat-resistant coat, heat-resistant gloves, and a full face shield over safety glasses. Use adequate ventilation for fumes.

CAUTION!

Mechanical hazard – risk of damage to the cold deck. Only use a soft brass or hardwood chisel to remove LSR from the cold deck.

5. Remove the LSR deposits or dust from the outside of the backup pads and manifold pocket area.
6. If required, use a brass rod to clean the inside of the backup pads. Do not scratch or score the backup pad surface.
7. Remove the LSR deposits or dust from the sealing insert on the backup pad.
8. Replace the O-rings on manifold bushing inserts.
9. Install the backup pads or cylinders on the manifold.

For information about installing backup pads, refer to [Section 6.7](#).

10. Install the backing plate. Refer to [Section 6.5](#) for more information.
11. Install the cold deck into the machine. Refer to [Section 4.3](#) for more information.

Chapter 7 Storage and Shipping

Cold deck surfaces are sensitive to many environmental conditions and require special methods for storage and shipping to avoid damage.

NOTE:

The storage instructions in [Section 7.2](#) are recommended when shipping the cold deck by air.

NOTE:

The storage instructions in [Section 7.3](#) are recommended when shipping the cold deck overseas.

CAUTION!

Mechanical hazard – risk of damage to the cold deck. Store all cold decks in an air conditioned environment.

7.1 Corrosion Protection

Humidity, salt in the air, rapid weather changes, and even condensation that forms during operation can quickly damage an unprotected cold deck.

Use a protective spray that does not contain chlorofluorocarbons (CFCs), has good moisture and oxidation resistance, and is resistant to mild acids and alkaline.

For additional corrosion protection during storage, add a moisture-absorbing silicate bag before sealing the cold deck in a vacuum polyethylene bag.

**WARNING!**

Poison hazard – risk of death or serious injury. Before using any corrosion protection product, always follow the supplier's recommendations for use and thoroughly review the Material Safety Data Sheet (MSDS).

7.2 Short Term Storage

Short term storage is intended for periods less than three months and can be done either in the machine or separately.

7.2.1 Storing in the Machine

To store the cold deck in the machine, do the following:

1. Open the clamp to full shutheight.
2. Lock out and tag the machine and controller (if equipped). Refer to [Section 2.5](#) for more information.
3. Clean the mold, cold deck and molding surfaces of dirt, debris and condensation.
4. Perform all required preventive maintenance procedures. Refer to [Section 6.1.1](#) for more information.
5. Inspect all moving components for damage. Replace or repair as needed.



WARNING!

Poison hazard – risk of death or serious injury. Protective sprays can cause headaches, dizziness, nausea and anesthetic effects. Wear a face shield and solvent resistant gloves. If used in an enclosed area, use an organic vapor respirator or self-contained breathing apparatus.

6. Spray all accessible faces and molding surfaces with a protective spray. Allow surfaces to dry for approximately two hours. Refer to [Section 3.5](#) for information about recommended lubricants.

If additional coats are required, make sure the cold deck has thoroughly dried before the next application.

7. Leave the mold open.

7.2.2 Storing Outside the Machine

To store the cold deck separately from the machine for a period of less than three months, do the following:

1. Open the clamp to full shutheight.
2. Lock out and tag the machine and controller (if equipped). Refer to [Section 2.5](#) for more information.
3. Purge all cooling water from the cold deck. Refer to the machine manufacturer's documentation for more information.
4. Clean the mold, cold deck and molding surfaces of dirt, debris and condensation.
5. Perform all required preventive maintenance procedures as required. Refer to [Section 6.1.1](#) for more information.
6. Inspect all moving components for damage. Replace or repair as needed.

**WARNING!**

Poison hazard – risk of death or serious injury. Protective sprays can cause headaches, dizziness, nausea and anesthetic effects. Wear a face shield and solvent resistant gloves. If used in an enclosed area, use an organic vapor respirator or self-contained breathing apparatus.

7. Spray all accessible faces and molding surfaces with protective spray. Allow surfaces to dry for approximately two hours. Refer to [Section 3.5](#) for specifications on protective spray
If additional coats are required, make sure the cold deck has thoroughly dried before the next application.
8. Remove the cold deck from the machine. Refer to [Section 4.3](#) for more information.
9. Place a cover over the cold deck to protect it during storage.
10. Store the cold deck in an air conditioned environment.

7.3 Long Term Storage

To store the mold and/or cold deck for a period of more than three months, do the following:

NOTE:

The following procedure can also be used to store spare parts.

1. Prepare the mold and/or cold deck for storage and remove it from the machine. Refer to [Section 7.2.2](#) for more information.
2. Place the mold and/or cold deck on a wooden platform.
3. Place the mold and/or cold deck in a 0.1 mm (0.004 in) or heavier (thicker) polyethylene bag along with a suitably sized moisture absorbing silicate bag.
The silicate bag offers additional corrosion protection.
4. Remove the lift bar and hoist ring.
5. Vacuum heat seal the polyethylene bag to retain the protective spray and prevent invasion of dirt or moisture.

7.4 Shipping the Cold Deck

The following guidelines should be followed when shipping a cold deck:

CAUTION!

Mechanical hazard – risk of damage to equipment. Residual coolant could freeze when transporting the cold deck in cold climates. Make sure all coolant is drained fully from the system before transporting it. Failure to do so could cause severe damage to the cold deck.

1. Before shipping the cold deck, check that all coolant has been drained fully.
2. Pack the cold deck, regardless of where it is being shipped, in a shipping crate. This will provide the best possible protection from any damage.
3. When returning a mold and/or cold deck to Husky for refurbishing, include the following items for testing purposes:
 - All electrical cables and switch boxes
 - All lift bars and latch bars installed in their shipping position on the cold deck
 - All mechanisms that had to be removed from the cold deck for any reason