

PRONTO --- Guide



HUSKY

Keeping our customers in the lead

PRONTO Overview

Benefits

Faster Delivery*

- Competitive lead times for up to 8 drops
- 25% reduction in 12-32 drop lead times

Easy to Order

- PRONTO Section in Hot Runner Product Guide
 - Readily available information

No Compromise in Quality

- Optimized melt channels
 - Leak proof warranty

Lower Price*

- 15% to 20% reduction

Features

Optimized Processing

- Ultra 350, 500, 750 and 1000 VG and HT, Ultra 250 HT
- Melt channels customized for each application

Flexible Pitch

- 1-32 drop manifold and hot runner systems (1-4 drops for Ultra 1000)
- 17 different manifold layouts
- Even profile for every application
- Balanced manifold layouts with level changes and thermally validated heater design ensure optimized processing for all applications

Configurable plates

- Flexible plate size
- Customer specified guide pin and interface taps
- Multiple clamping options including DME and oversized backing plate

** Applications requiring custom components will not be given PRONTO lead time or price*



Design for PRONTO

5 step process for PRONTO eligibility

1. Nozzle Length
2. Sprue Clearance
3. Pitch spacing
4. Plate Sizes
5. Configurable system options

Step 1—Nozzle Length

- Must fall within range of min/max
- Any increment within range
 - Same for VG/HT

** Longer lead time*

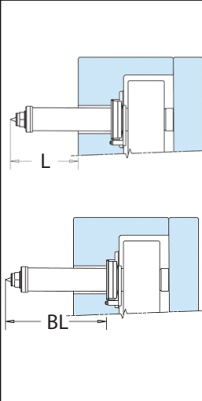

Nozzle	Gate	Min-L	Max-L	Ext-L*
U250	HT	17 [.66"]	170 [6.60"]	-
U350	HT/ VG	17 [.66"]	170 [6.60"]	-
	VG	20 [.78"]	230 [9.05"]	290 [11.41"]
U500	HT	14 [.55"]	230 [9.05"]	290 [11.41"]
	VG	27.4 [1.08"]	180 [7.08"]	290 [11.41"]
U750	HT	27.4 [1.08"]	230 [9.05"]	290 [11.41"]
	VG	29.3 [1.15"]	250 [9.84"]	300 [11.81"]
U1000	HT	28[1.10"]	300 [11.81"]	-

Nozzle	Gate	Min BL	Max BL	Ext-BL*
U250	HT	53 [2.08"]	185 [7.28"]	-
U350	HT/ VG	53 [2.08"]	185 [7.28"]	-
	VG	85 [3.34"]	245 [9.64"]	305 [12"]
U500	HT	70 [2.75"]	245 [9.64"]	305 [12"]
	VG	64 [2.51"]	195 [7.67"]	305 [12"]
U750	HT	57 [2.24"]	245 [9.64"]	305 [12"]
	VG	82 [3.22"]	270 [10.62"]	320 [12.59"]
U1000	HT	82 [3.22"]	320 [12.64"]	-

Step 2—Sprue Clearance

- Minimum distance from inner drop to sprue (Min Drop)
- Allows for standard design/components
- Maximum manifold size (Max Drop)
 - Distance from outer most drop to sprue

*** Air Plate out of scope for U1000 PRONTO*

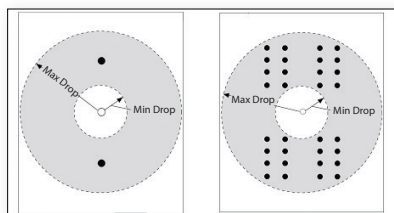

Gating	Nozzle	Min Drop	Max Drop
Hot Tip	U250	31.8 [1.25"]	300 [11.8"]
	U350	31.8 [1.25"]	300 [11.8"]
	U500	32 [1.26"]	500 [20.4"]
	U750	40.4 [1.59"]	
	U1000	50 [1.97"]	
Valve Gate	U350	SX- 45 [1.77"] LX- 50 [1.96"]	300 [11.8"]
	U500		
	U750	LX- 50 [1.96"] EX- 65 [2.55"]	400 [15.7"]
	U1000	72 [2.83"]**	500 [19.7"]

Design for PRONTO

Step 3—Pitch Spacing

- Same spacing requirements as our custom systems
- Dependent on nozzle size and gating style
 - Allows for standard design/ components

Gate	Nozzle	Min Pitch
Hot Tip	Ultra 250	18 [.71"]
	Ultra 350	18 [.71"]
	Ultra 500	25.4 [1"]
	Ultra 750	44.5 [1.75"]
	Ultra1000	61 [2.4"]
Valve Gate	Ultra 350	SX 25.4 [1"]
	Ultra 500	LX 50 [1.96"]
	Ultra 750	LX 50 [1.96"] EX 59 [2.33"]
	Ultra1000	75 [2.95"]

 = Ultra 1000 PRONTO only available in these layouts

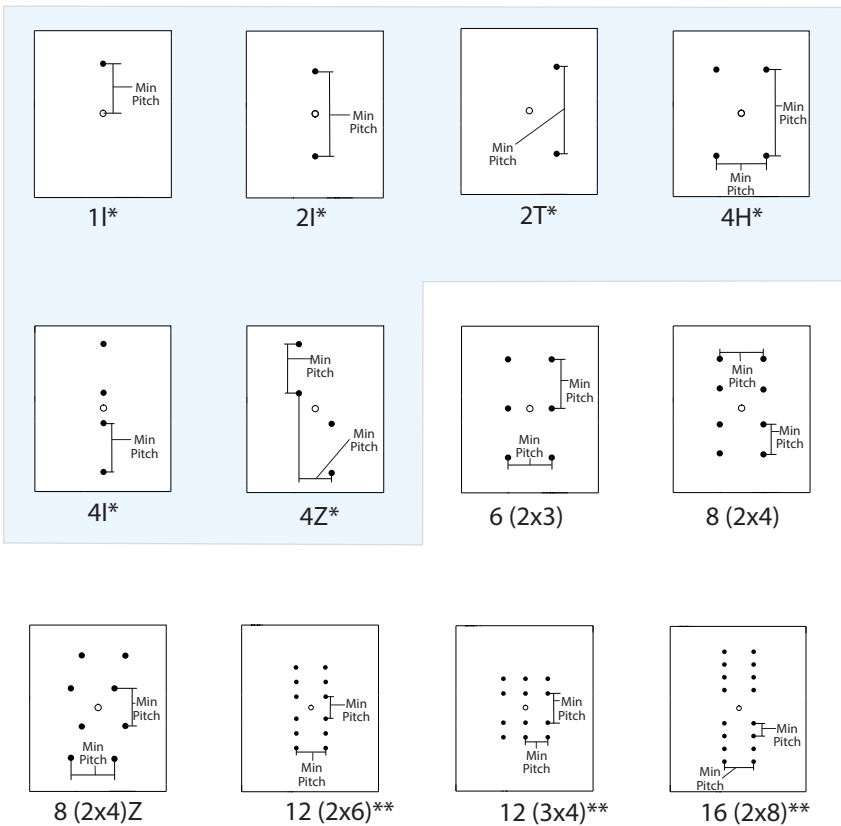

Design for PRONTO

Step 3—Pitch Spacing (Continued)

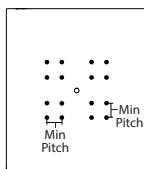

16 (4x4)**

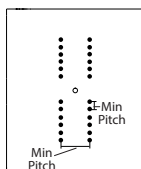

24 (2x12)**

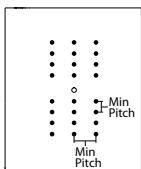

24 (3x8)**

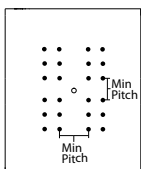

24 (6x4)**

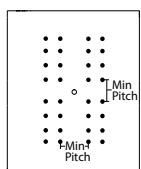

32 (4x8)**

* Pitch Flexibility

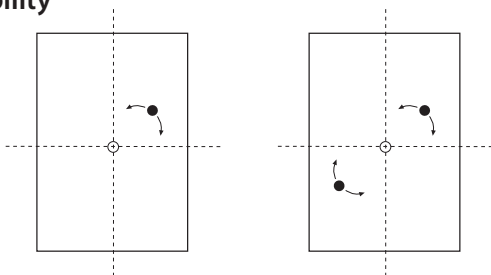

Pitch locations for 1 and 2 drop PRONTO systems are fully flexible and can be rotated about the injection point.

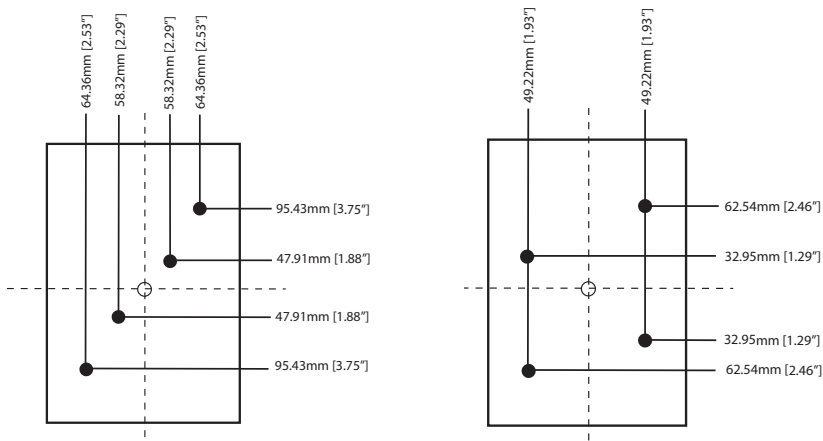

Pitch location for 4 Drop PRONTO systems is available in both symmetrical and asymmetrical configurations. Asymmetrical layouts still require injection to be located at the center of the mold. As seen in the example, drop locations must feature the same dimensions in two different quadrants. For example the inner drops are both located at (58.32, 47.91) and the outer drops are both located at (64.36, 95.43)

Design for PRONTO

Step 3—Pitch Spacing (Continued)

** For systems 12 -drops and above pitch spacings (vertical and horizontal) must be equal. [Spacing across the sprue (0,0) may vary] i.e. as shown

* May vary - See sprue clearance (Step 2)

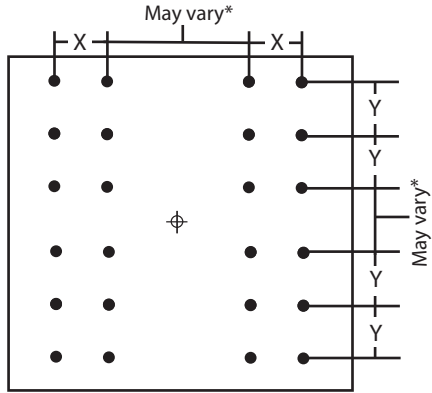

Step 4—Plate Sizing

- Confirm plate sizes are within the maximum available width and height
- Check that all drop locations fit within the “area available for drops”
(leaving adequate open space at the edge of the plates)

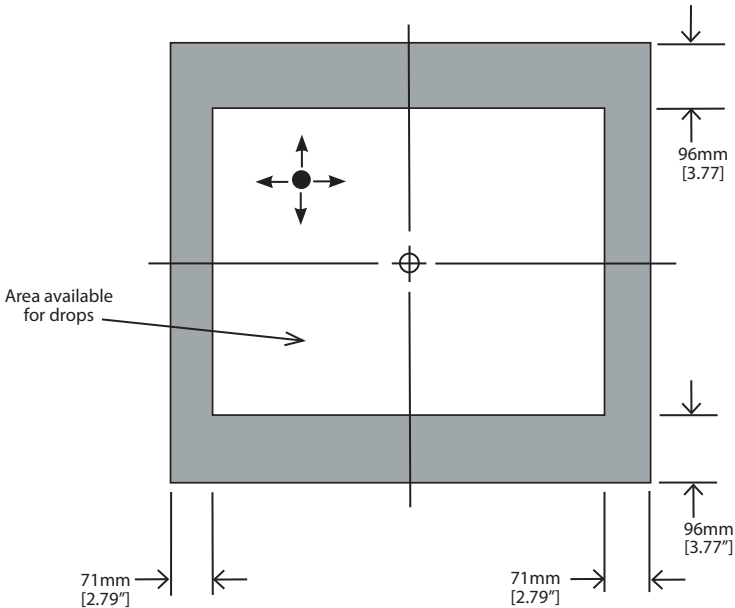

Maximum Plate Width : 1200mm [47.3"]

Maximum Plate Height : 1500mm [61.0"]

Design for PRONTO

Step 5—Configurable Options

(Ultra 350 thru Ultra 1000)

- Clamping Options
 - Benefits
 - Easy specification
 - Predictable design
 - Features
 - Industry standard clamping
 - Choice of clamping thickness

DME- Style Clamping

Clamp Thickness						
	A		B		C (min)	
	Metric	Imperial	Metric	Imperial	Metric	Imperial
Standard	22.2mm	0.87"	16mm	0.62"	23.8mm	0.93"
Optional	Customer to specify					

Over Size Backing Plate

- Electrical Options
 - Requirements
 - Top Locations
 - Choose from standard connector offering

Electrical Configurations		
Pins	Latches	Supplier
6	Double or Single	DME Lapp Harting
16		
24		
25		
32		
48		

- Guide Pins and Interface Options
 - Guide Pins
 - DME/Hasco
 - Any size, location, qty
 - Interface Options
 - Metric/Imperial
 - Any size, location, qty

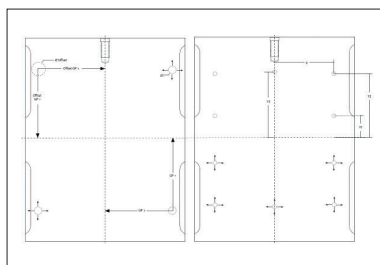

Design for PRONTO

Step 5—Configurable Options *(Continued)*

- Utility Locations
 - Water
 - Air

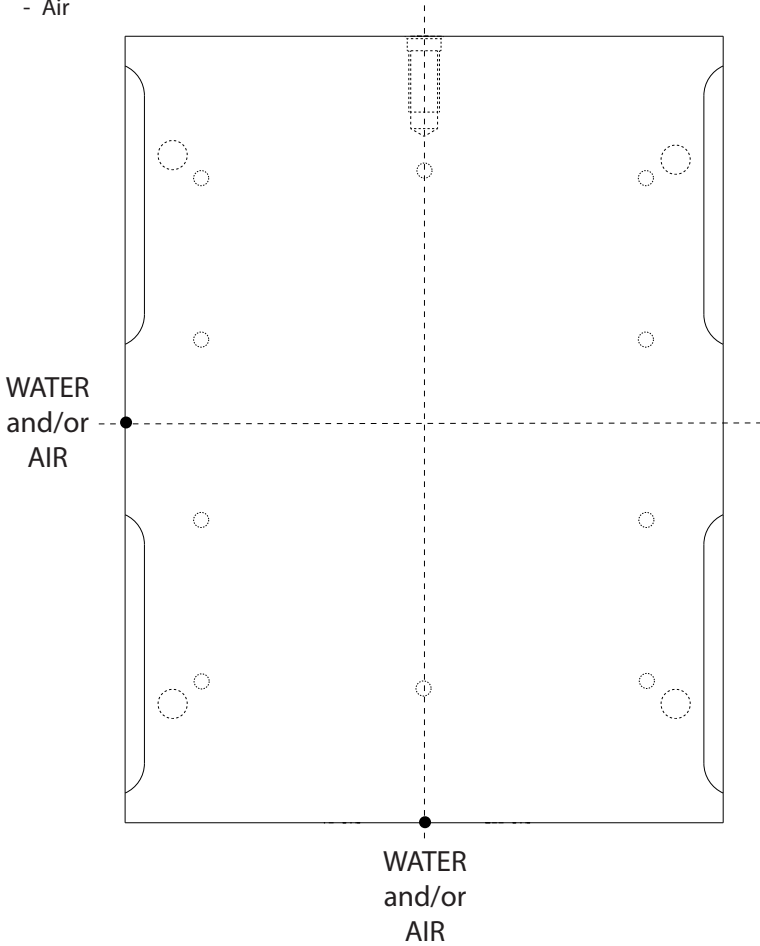

	Available Fittings				
	DME	Festo	Hasco	Parker	Staubli
Air	✓	✓	✓	✓	✓
Water	✓		✓	✓	✓

Design for PRONTO

Step 5—Configurable Options-Custom Cutouts

- Installations:
 - Back-up cutouts
 - Latch cutouts
 - Cutouts for bolting
- Requirements:
 - Manufacturing tolerance +/- 0.2 mm

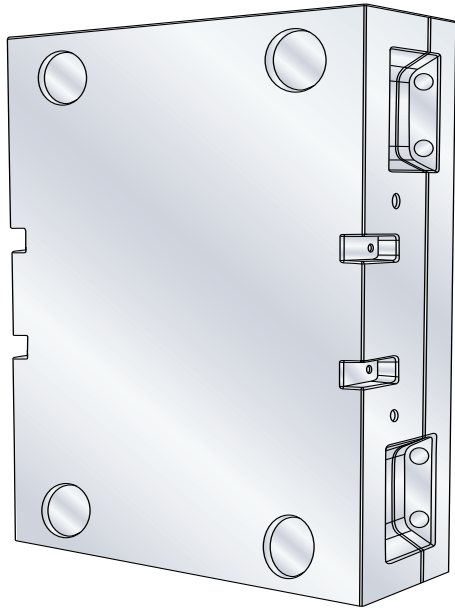

PRONTO – FAQ

Q: What items are allowable in PRONTO systems:

- A:
- Customized plate cutouts with manufacturing tolerances +/-0.2 mm
 - If drop to plate edge is at the min, cut-outs should be reviewed by Husky Project Engineer, plate thickness might be increased by depth of cutouts
 - There are no limits in # of cut-outs, but should be enough space for wire grooves and if cut-outs are not in the corners, it should be reviewed by Husky Project Engineer
 - Sequential Valve Gate limited to 4 drops Hot Runner systems
 - Must be reviewed by Husky Project Engineer, additional circuits and limited space would be constrain to install other standard features
 - Customized items like loc. ring, sprue bushing at an additional cost and lead time checked with Husky factory
 - Corrosive/high pressure/high temp application at an additional cost and increased lead time
 - Different nozzle length are allowable for PRONTO. Moldflow may be required with 2 different L-dims
 - EMI is allowable if is required by application guidelines
 - Powertech Box installation

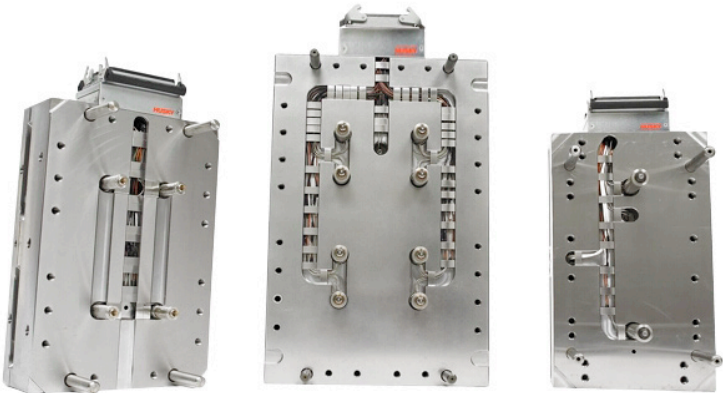

PRONTO – FAQ

Q: Which items do not fit within PRONTO?

A: The following items do not fit into PRONTO but may be available through our custom systems:

- Special shut-off geometry (angle, diameter, tolerances)
- Contoured gate (HT or VG)
- Special gate insert design or gate manufacturing request from customer except UltraHelix
- Interface taps from backing plate to customer mold, because it leads to customized design of hot runner
- Offset injection location, because it might lead to unbalanced system and custom design
- Reverse taper stem, customized manifold bushings
- Customer circuits in Hot Runner plates
- Thru-holes
- Modified gate land, gate bubble or customized nozzle tip are allowable after review by Husky application engineer and part number should be provided with project specification

If your application requires any of these items please contact Husky to inquire about our custom hot runner

Q: Can repeat discount should be applied?

A: No, repeat discount is not available.

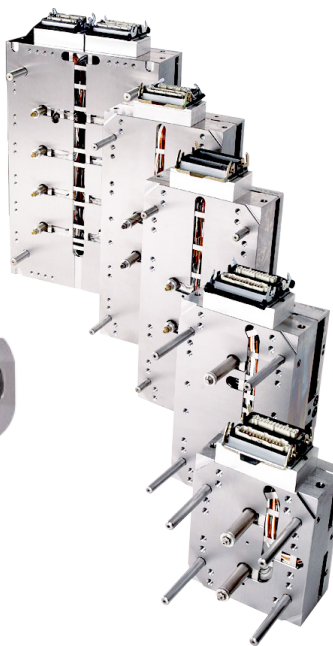
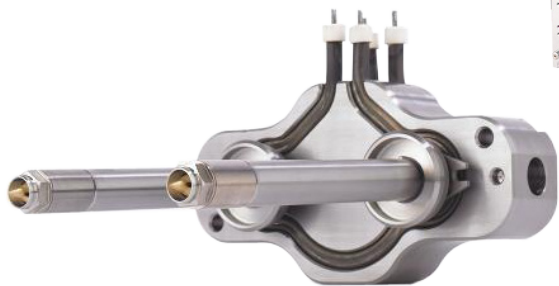

RECYCLABLE



Husky actively protects its technical and design innovations through a global intellectual property strategy. Husky currently has more than 900 patents and patent applications worldwide. The equipment shown in this publication may be covered by one or more of these patents.

®/© 2016 Husky Injection Molding Systems Ltd. January 2016