

Unify Manifold System

Hot Runner Installation Manual

Issue: v 2.2 — March 2021

Document No.: 7593574

This product manual is intended to provide information for safe operation and/or maintenance. Husky reserves the right to make changes to products in an effort to continually improve the product features and/or performance. These changes may result in different and/or additional safety measures that are communicated to customers through bulletins as changes occur.

This document contains information which is the exclusive property of Husky Injection Molding Systems Limited. Except for any rights expressly granted by contract, no further publication or commercial use may be made of this document, in whole or in part, without the prior written permission of Husky Injection Molding Systems Limited.

Notwithstanding the foregoing, Husky Injection Molding Systems Limited grants permission to its customers to reproduce this document for limited internal use only.

Husky[®] product or service names or logos referenced in these materials are trademarks of Husky Injection Molding Systems Ltd. and may be used by certain of its affiliated companies under license.

All third-party trademarks are the property of the respective third-party and may be protected by applicable copyright, trademark or other intellectual property laws and treaties. Each such third-party expressly reserves all rights into such intellectual property.

©2016 – 2021 Husky Injection Molding Systems Ltd. All rights reserved.

General Information

Telephone Support Numbers

North America	Toll free	1-800-465-HUSKY (4875)
Europe	EC (most countries)	008000 800 4300
	Direct and Non-EC	+ (352) 52115-4300
Asia	Toll Free	800-820-1667
	Direct:	+86-21-3849-4520
Latin America	Brazil	+55-11-4589-7200
	Mexico	+52-5550891160 option 5

For on-site service, contact your nearest Husky Regional Service and Sales office.

For non-emergency questions and issues you may also e-mail Husky at techsupport@husky.ca.

Husky Regional Service and Sales Offices

For the location closest to you, please visit www.husky.co.

Product Upgrades

Upgrades are available that can improve your output, reduce cycle times, and add functionality to your Husky equipment.

To see what upgrades are available for your Husky equipment, visit our website at www.husky.co or call your nearest Husky Regional Service and Sales Office.

Ordering Spare Parts

All spare parts for Husky equipment can be ordered through your nearest Husky Parts Distribution Center or online at www.husky.co.

Hot Runner Refurbishing

Husky offers services for repairing, modifying, and retrofitting Husky hot runners. Contact your Husky Regional Service and Sales office for details.

Table of Contents

General Information.....	iii
Telephone Support Numbers.....	iii
Husky Regional Service and Sales Offices.....	iii
Product Upgrades.....	iii
Ordering Spare Parts.....	iii
Hot Runner Refurbishing.....	iv
Chapter 1: Introduction.....	9
1.1 Purpose of the Equipment.....	9
1.2 Restrictions of Use.....	9
1.3 Unauthorized Modifications.....	9
1.4 Auxiliary Equipment.....	9
1.5 Documentation.....	10
1.5.1 Manuals.....	10
1.5.2 Engineering Drawings and Schematics.....	11
1.5.3 Safety Alert Conventions.....	11
1.6 Training.....	12
1.7 Nameplates.....	12
1.7.1 Hot Runner Nameplate.....	12
1.8 Special Tools.....	14
1.8.1 Nozzle Tip Sockets and Heater Removal Tools.....	14
1.8.2 Standard Nozzle Tip Sockets.....	14
1.8.3 Thermocouple Wire Stripping Tools.....	15
1.8.4 Single Probe Thermocouple Removal Tools.....	15
1.8.5 Crimping Tools for Contact Pins (25 or 64 Pin Connectors).....	15
1.8.6 Unify Nozzle Assembly Tool.....	16
1.8.7 Unify Hydraulic Actuator Seal Installation Tools.....	16
Chapter 2: Safety Summary.....	17
2.1 Qualified Personnel.....	17
2.2 Safety Guidelines.....	17
2.3 Safety Hazards.....	17
2.3.1 Mechanical Hazards.....	18
2.3.2 Burn Hazards.....	18
2.3.3 High Pressure Hazards.....	19
2.3.3.1 Hydraulic System Pressure Hazards.....	20
2.3.4 Electrical Hazards.....	20
2.3.5 Gas, Vapor and Dust Emissions.....	20
2.3.6 Slip, Trip or Fall Hazards.....	21
2.3.7 Lifting Hazards.....	21
2.4 Safety Signs.....	21
2.5 Lockout and Tagout.....	23
2.6 Personal Protective Equipment and Safety Equipment.....	24

2.6.1	Personal Protective Equipment (PPE).....	24
2.6.2	Safety Equipment.....	25
2.7	Material Safety Data Sheet (MSDS).....	25
2.8	Materials, Parts and Processing.....	26
2.9	Safety Latch Bars.....	26
2.10	Lift Bars and Swivel Hoist Rings.....	27
Chapter 3:	Specifications.....	29
3.1	Weight.....	29
3.2	Operating Temperature.....	29
3.3	Electrical System Specifications.....	29
3.3.1	Controller Requirements.....	29
3.3.2	Nozzle Heaters.....	30
3.3.3	Manifold Heaters.....	30
3.3.3.1	Spare Thermocouple Wires.....	30
3.3.4	Power Fluctuation.....	31
3.4	Operating Specifications.....	31
3.4.1	Hydraulic Manifold Operating Limits.....	31
3.4.2	Pneumatic Manifold Operating Limits.....	32
3.5	Hydraulic Fluid Specifications.....	32
3.6	Pneumatic Specifications.....	32
3.7	Hydraulic Cooling Water Specifications.....	33
3.8	Pneumatic Cooling Water Specifications.....	33
3.9	Recommended Lubricants.....	34
3.10	Rust Inhibitor Specifications.....	35
3.11	Torque Specifications.....	35
3.12	Hydraulic and Pneumatic Actuator Component Specifications.....	36
3.12.1	Large Hydraulic Actuator Components.....	36
3.12.2	Small Hydraulic Actuator Components.....	37
3.12.3	Large and Small Pneumatic Actuator Components.....	39
3.12.4	Large and Small Pneumatic Actuator with Thermal Regulator Components.....	40
Chapter 4:	Installation and Removal.....	43
4.1	Lifting and Handling.....	43
4.1.1	Lifting and Handling Using a Single Lifting Point.....	44
4.1.1.1	Laying Down Plates Using a Single Lifting Point.....	44
4.1.1.2	Picking Up Plates Using a Single Lifting Point.....	45
4.1.2	Lifting and Handling Using Multiple Lifting Points.....	46
4.1.3	Lifting Using a Lift Bar.....	47
4.1.4	Lifting Using Swivel Hoist Rings.....	48
4.2	Installing and Removing the Manifold Assembly.....	49
4.2.1	Installing the Manifold into the Plates.....	49
4.2.2	Removing the Manifold assembly from the Mold.....	52
Chapter 5:	Startup and Operation.....	55
5.1	Preparing the Hot Runner.....	55
5.2	Heating Up the Hot Runner, Mold and Machine.....	56

5.3	Precharging the Hot Runner.....	57
5.4	Producing Test Parts.....	58
Chapter 6:	Maintenance.....	61
6.1	Scheduled and Non-Scheduled Maintenance.....	61
6.1.1	Preventive Maintenance.....	62
6.1.2	Service Procedures.....	62
6.2	Removing and Installing Nozzle Stacks.....	63
6.2.1	Removing the Nozzle Stack.....	63
6.2.2	Installing the Nozzle Stack.....	63
6.3	Changing the Resin Color.....	66
6.4	Extending Nozzle and Sprue Heater Wire Leads.....	67
6.5	Removing and Installing the Hydraulic Actuator	69
6.5.1	Removing the Hydraulic Actuator from the Manifold.....	69
6.5.2	Installing the Hydraulic Actuator on the Manifold.....	70
6.6	Removing and Installing the Pneumatic Actuator	72
6.6.1	Removing the Pneumatic Actuator from the Manifold.....	72
6.6.2	Installing the Pneumatic Actuator to the Manifold.....	73
6.7	Adjusting the Valve Stem Preload for Hydraulic Actuators.....	74
6.8	Replacing the Hydraulic and Pneumatic Seals.....	78
6.9	Removing and Installing Valve Stems.....	78
6.9.1	Removing a Valve Stem.....	78
6.9.2	Installing a Valve Stem.....	79
6.10	Removing and Installing Nozzle Heaters.....	79
6.10.1	Removing and Installing Ultra Nozzle Heaters (UNH) on U750 Systems.....	80
6.10.1.1	Removing Ultra Nozzle Heaters (UNH) on U750 Systems.....	80
6.10.1.2	Installing Ultra Nozzle Heaters (UNH) on U750 Systems.....	80
6.10.2	Removing and Installing Ultra Nozzle Heaters (UNH) With Ring Thermocouples.....	83
6.10.2.1	Removing Ultra Nozzle Heaters (UNH) With Ring Thermocouples.....	83
6.10.2.2	Installing Ultra Nozzle Heaters (UNH) With Ring Thermocouples.....	84
6.10.3	Removing and Installing Bi-Metal Heaters on U750 and U1000 Systems.....	89
6.10.3.1	Removing Bi-Metal Nozzle Heaters on U750 and U1000 Systems.....	89
6.10.3.2	Installing Bi-Metal Nozzle Heaters on U750 and U1000 Systems.....	89
6.10.4	Removing and Installing Triton Heaters on U750-UP Systems.....	92
6.10.4.1	Removing Triton Nozzle Heaters on U750-UP Systems.....	92
6.10.4.2	Installing Triton Nozzle Heaters on U750-UP Systems.....	93
6.10.5	Removing and Installing HTM Nozzle Heaters for U1000 Systems.....	95
6.11	Replacing the Hydraulic or Pneumatic Manifold Hoses	95
6.12	Grounding the Unify System.....	96
6.13	Testing Heaters.....	97
6.14	Removing and Installing the Cavity Plate.....	97
6.14.1	Removing the Cavity Plate On a Work Bench.....	98
6.14.2	Installing the Cavity Plate On a Work Bench.....	99
6.14.3	Removing the Cavity Plate In the Machine.....	101
6.14.4	Installing the Cavity Plate In the Machine.....	103
6.15	Inspecting and Cleaning Manifolds.....	104
6.15.1	Cleaning Using a Fluidized Bed Process.....	105
6.15.1.1	Assistance.....	106

6.15.1.2	Disassembling the Hot Runner for Fluidized Bed Cleaning.....	106
6.15.1.3	Removing the PEEK Bushings.....	108
6.16	Removing Insulating Gate Bubbles (If Equipped).....	108
6.17	Removing and Installing the Sprue Heater (If Equipped).....	112
6.17.1	Removing a Sprue Heater with a Built-In Thermocouple.....	112
6.17.2	Removing a Sprue Heater with a Separate Thermocouple.....	112
6.17.3	Installing a Sprue Heater with a Built-In Thermocouple.....	113
6.17.4	Installing a Sprue Heater with a Separate Thermocouple.....	114
6.18	Removing and Installing the Sprue Bushing.....	115
6.18.1	Removing the Sprue Bushing.....	116
6.18.2	Installing the Sprue Bushing.....	116
6.19	Removing and Installing Nozzle Tip Insulators (If Equipped).....	118
6.19.1	Removing the Nozzle Tip Insulators.....	118
6.19.2	Installing Nozzle Tip Insulators.....	119
Chapter 7:	Storage and Shipping.....	121
7.1	Corrosion Protection.....	121
7.2	Short Term Storage.....	121
7.2.1	Storing in the Machine.....	122
7.2.2	Storing Outside the Machine.....	122
7.3	Long Term Storage.....	123
7.4	Shipping the Hot Runner.....	123

Chapter 1 Introduction

This chapter describes the manifold system, training opportunities, and the available equipment manuals.

1.1 Purpose of the Equipment

Husky equipment and systems are designed for injection molding applications only, using approved materials and operating within design guidelines.

Contact your nearest Husky Regional Service and Sales office if you plan to use a Husky product for anything other than its intended use.

1.2 Restrictions of Use

Husky injection molding equipment must never be:

- operated by more than one person
- used for any purpose other than that described in [Section 1.1](#), unless otherwise approved by Husky
- used to extrude any materials not outlined in the scope of the harmonized EN201 or ANSI B151.1 standard
- operated or serviced by personnel unfamiliar with the inherent risks and necessary precautions related to injection molding equipment
- operated at temperatures higher than the maximum permissible temperature for the resin

1.3 Unauthorized Modifications

Unauthorized modifications or reconstruction of any Husky injection molding system is strictly prohibited. Modifications can be unsafe and/or void warranty.

Contact your nearest Husky Regional Service and Sales office to discuss modifications or requirements for Husky systems.

1.4 Auxiliary Equipment

Husky is only responsible for the interaction of Husky equipment and systems with auxiliary equipment when Husky is the system integrator. If auxiliary equipment is removed, the user must install proper safeguards to prevent access to the hazards.

For information about integrating non-Husky auxiliary equipment, contact your nearest Husky Regional Service and Sales office.

1.5 Documentation

A full set of manuals, drawings, schematics, certificates and other documentation are available for every Husky hot runner.

The following describes the documentation provided with each system, along with common conventions all readers should be familiar with.



IMPORTANT!

Keep all manuals in a convenient location for future reference.

1.5.1 Manuals

Husky manuals aid in the safe and proper use of Husky products. Where applicable, the manuals provide instructions on installation, operation and maintenance.

Personnel should thoroughly review all manuals provided with their Husky equipment prior to performing any tasks. Proceed with tasks only if all instructions are understood and always follow applicable workplace safety requirements.



IMPORTANT!

Images in the manuals are for reference only and may not represent specific equipment details. Refer to engineering drawings and schematics and the HMI for specific details.

The following manuals are provided with each Husky machine upon delivery:

Installation Manual	Describes the basic installation of the manifold system.
Service Manual	Describes the installation, startup, operation, shut down and maintenance of the hot runner system. NOTE: Refer to the hot runner <i>Service Manual</i> for specific removal and maintenance instructions.

These manuals are available online through www.husky.co.

**IMPORTANT!**

Some manuals may contain addendums that detail new or updated information. Before reading a manual, make sure to review all available addendums located at the end of the manual.

1.5.2 Engineering Drawings and Schematics

Each Husky hot runner is provided with a set of drawings and schematics specific to the hot runner. These are used for troubleshooting the hot runner and ordering spare parts.

NOTE:

Each drawing and schematic is specific to the hot runner it is provided with.

1.5.3 Safety Alert Conventions

Safety alerts highlight hazardous conditions that may arise during installation, operation or maintenance and describe methods for avoiding personal injury and/or property damage.

Depending on the severity of the hazard, safety alerts start with one of the following signal words: Danger, Warning or Caution.

**DANGER!**

The DANGER safety alert indicates an imminently hazardous situation that, if not avoided, will result in death or serious injury.

**WARNING!**

The WARNING safety alert indicates a potentially hazardous situation that, if not avoided, could result in death or serious injury.

CAUTION!

The CAUTION safety alert indicates a potentially hazardous situation that, if not avoided, could result in property damage.

Other non-safety related alert types used in the manuals highlight important information needed by the user to install, operate or maintain the equipment properly. They may also, in some cases, describe best practices, offer an expanded explanation, or reference a related section in the manual.

Non-safety related alerts start with one of the following signal words: Note or Important.

NOTE:

The NOTE alert is used to add information to a subject that does not fit within the general flow of the document.

**IMPORTANT!**

The IMPORTANT alert is used to highlight important steps, conditions, or considerations related to the subject.

1.6 Training

All designated operators and maintenance personnel must be fully trained before using or servicing Husky injection molding systems.

If training is required, visit www.husky.co or contact your nearest Husky Regional Service and Sales office to learn more about Husky's training solutions.

**IMPORTANT!**

It is the obligation of the employer to properly train and instruct all personnel in the safe methods of operation and maintenance. Manuals and other reference material, which have been prepared by Husky for the operation and maintenance of Husky equipment, do not in any way absolve the employer from fulfilling these obligations and Husky disclaims liability for injury to personnel which is attributable to the employer's failure to do so.

1.7 Nameplates

Nameplates are affixed to the operator's side of the mold and hot runner for quick identification of the equipment type, source and general specifications.

**IMPORTANT!**

The mold and hot runner nameplates must never be removed. The information on the nameplates is necessary for mold selection, setup, parts ordering and troubleshooting.

Immediately order a new nameplate for the mold or hot runner if it is missing or damaged.

1.7.1 Hot Runner Nameplate

Every hot runner nameplate lists the following information:

- the location where the hot runner was manufactured
- the project number
- the material type allowed to be used in the hot runner
- the melt and mold temperatures
- electrical requirements and specifications

NOTE:

Other details and specifications may be required.

**IMPORTANT!**

Each hot runner is designed to process a specific type and grade of resin/filler based on the customer's requirements. Use of any other type or grade of resin/filler could affect part quality and/or the performance of the hot runner. Before using a different type or grade of resin/filler, contact Husky.

CAUTION!

Mechanical hazard – risk of damage to the hot runner. Never operate the hot runner outside of the melt and mold temperatures indicated on the nameplate. Internal resin leakage or component damage could occur.

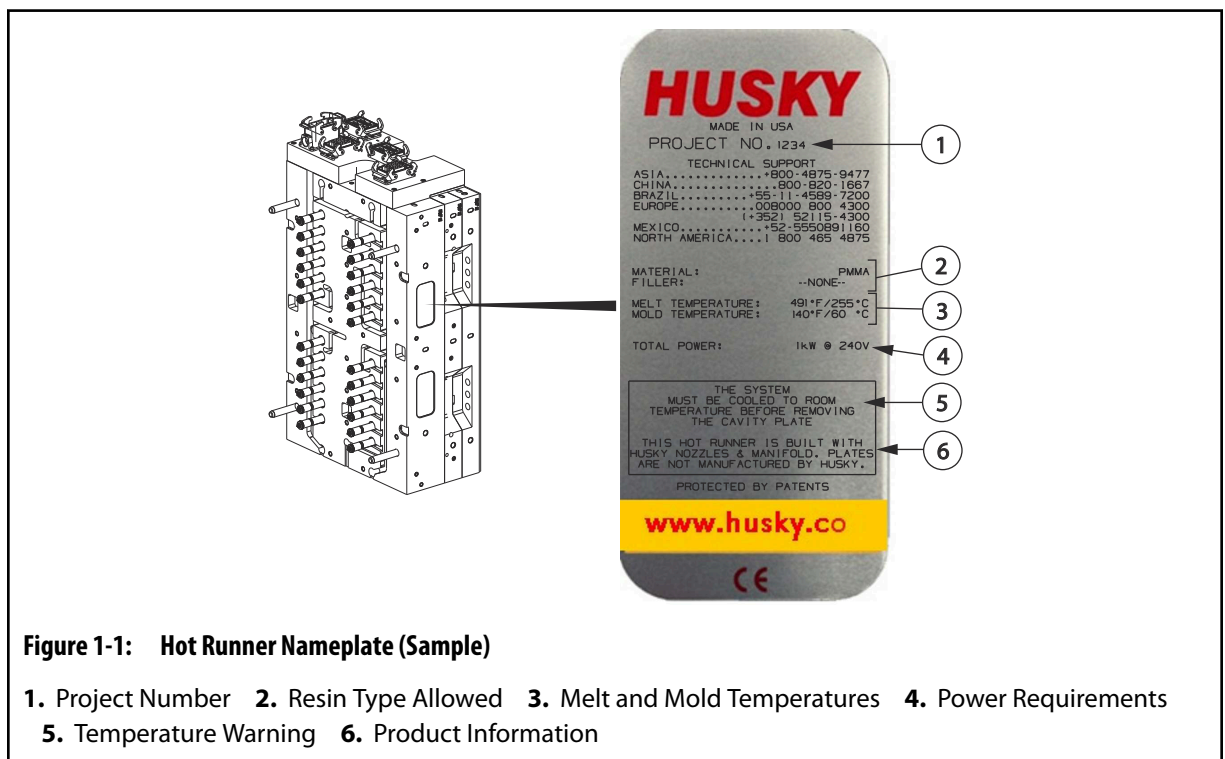

Figure 1-1: Hot Runner Nameplate (Sample)

1. Project Number 2. Resin Type Allowed 3. Melt and Mold Temperatures 4. Power Requirements
5. Temperature Warning 6. Product Information

1.8 Special Tools

The following sections list various component-specific tools developed by Husky for use during maintenance of hot runner systems. Contact Husky to order special tools applicable to your hot runner system.

1.8.1 Nozzle Tip Sockets and Heater Removal Tools

Nozzle	Tip	Part Number	
		Nozzle Tip Socket	Heater Removal Tool
U750	VG-R	531983	535160
	VG	2338059	
	VX	3253170	
U1000	VG	2449784	2410903 (Bi-Metal)
	VX	2816672	

1.8.2 Standard Nozzle Tip Sockets

Size	Points	Drive	Part Number
4 mm	6 (Allen Key)	3/8 inch	622974
6 mm	6 (Allen Key)	3/8 inch	622972
6mm	6	3/8 inch	533942
8 mm	6	1/4 inch	2996145
8 mm	12	1/4 inch	3436695
8 mm	6	3/8 inch	1501813
10 mm	12	3/8 inch	3253169
11 mm	6	3/8 inch	3320712
11 mm	12	3/8 inch	531983
12 mm	6	3/8 inch	2338059
13 mm	6	3/8 inch	536678
14 mm	12	3/8 inch	533533

Size	Points	Drive	Part Number
15 mm	6	3/8 inch	2449784
15 mm	12	3/8 inch	3253170
16 mm	6	3/8 inch	2402461
16 mm	12	3/8 inch	2816670
17 mm	6	3/8 inch	2308879
20 mm	6	1/2 inch	3722920
21 mm	12	1/2 inch	3274535
22 mm	6	1/2 inch	3311845
22 mm	12	1/2 inch	2816672
29 mm	6	1/2 inch	1502743
30 mm	6	1/2 inch	535571
1/2 inch	6	3/8 inch	2192309

1.8.3 Thermocouple Wire Stripping Tools

Description	Part Number
Strippers for Thermocouple Wires	4240042

1.8.4 Single Probe Thermocouple Removal Tools

Description	Part Number
11 mm Split Socket	4395427

1.8.5 Crimping Tools for Contact Pins (25 or 64 Pin Connectors)

Description	Part Number
Crimp Tool	2292562
Locator	2292574

Description		Part Number
Removal Tool		534645
Crimp Dies	0.5 to 1.5 mm ² (20 to 16 AWG) ^[1]	238569
	4.0 to 10 mm ² (12 to 8 AWG) ^[1]	2292575
	0.14 to 4.0 mm ² (26 to 12 AWG) ^[2]	2292576
	0.14 to 0.5 mm ² (26 to 20 AWG) ^[1]	2748316
	1.5 to 2.5 mm ² (16 to 14 AWG) ^[1]	2748326

^[1] Stamped crimp pins.

^[2] Machined crimp pins.

1.8.6 Unify Nozzle Assembly Tool

Nozzle	Part Number
Ultra 750	6685641
Ultra 1000	6611265

1.8.7 Unify Hydraulic Actuator Seal Installation Tools

Nozzle	Description	Part Number	
Ultra 750 / Ultra 1000	Tool Sub Assembly	6618499	
	This part is included in the sub assembly	Seal Base	6618449
		Rod Seal Spacer	6396598
		Seal Installation Tool	6469572
		Seal Mandrel	6469607
		Calibration Mandrel	6402092
		Piston Seal Resizing Tool	6467523
		Piston Seal Installation Tool	6396301

Chapter 2 Safety Summary

This chapter describes the general requirements and conditions for safe installation, operation and maintenance of the manifold system.

**IMPORTANT!**

Personnel must read, understand and follow all safety precautions.

**IMPORTANT!**

Personnel must follow applicable industry and regulatory safety requirements for safe installation, operation and maintenance of equipment.

2.1 Qualified Personnel

Only fully trained and qualified personnel should be permitted to maintain equipment. Qualified personnel must have demonstrated skills and knowledge related to the construction, installation and operation of the injection molding equipment and have received safety training on the hazards involved.

2.2 Safety Guidelines

Personnel operating, installing, maintaining or servicing Husky equipment must adhere to safe working practices that are in compliance with the following guidelines:

- Lockout and tag electrical, pneumatic and hydraulic energy sources before servicing the mold/hot runner or entering the mold area
- Do not operate the mold/hot runner if scheduled preventive maintenance has not been performed
- Do not use a magnetic platen without approval from Husky and the magnetic platen supplier/manufacturer
- Do not operate a hot runner outside the maximum melt and mold temperatures specified on the hot runner nameplate

2.3 Safety Hazards

Some common safety hazards associated with injection molding equipment are:

- Mechanical
- Electrical
- Burn
- High pressure (hydraulic system pressure and molten material spray)
- Slip, trip or fall
- Lifting
- Gas, vapor and dust emissions
- Noise

2.3.1 Mechanical Hazards

- **Worn Hoses and Safety Restraints**
Regularly inspect and replace all flexible hose assemblies and restraints.
- **Cooling Water Hoses**
Cooling water hoses degrade over time and need to be replaced on a yearly basis. Degraded hoses become brittle and can break or separate from the fitting when manipulated. To minimize the risk of failure, inspect the hoses regularly and replace as required.
Wait until the machine has cooled down before servicing cooling water hoses.
- **Seized Screws or Plugs**
If screws or plugs cannot be removed by normal methods using standard tooling and force, there is a high possibility these items have become seized; contact Husky for repair recommendation.



WARNING!

Mechanical and/or flying debris hazard - Tool breakage: risk projectile debris, serious injury and/or mechanical damage. Do not use excessive force and/or use tools beyond their designated limits. Do not use torque multiplying bars. Failure of tools may produce fragments that can become projectiles that may cause injury. For seized parts, consult Husky for safe disassembly instructions.

NOTE:

Manifold plugs are not a field repairable item and should never be removed. These items can only be serviced at a Husky manufacturing location.

2.3.2 Burn Hazards

- **Hot Surfaces**
The mold area, auxiliary mold equipment, and injection unit heating elements have numerous high temperature surfaces. At normal operating temperatures, contact with these surfaces will cause severe skin burns. These areas are clearly marked with safety signs. Wear personal protective equipment when working in these areas.

- **Molten Material**
Never touch process material purged or otherwise flowing from the nozzle, mold, hot runner or feed throat area. Molten material can appear cool on the surface, but remain very hot on the inside. Wear personal protective equipment when handling purged material.

2.3.3 High Pressure Hazards



WARNING!

Burn and hot resin spray hazard – risk of death, serious injury and/or damage to the hot runner. All nozzle and sprue heaters (if equipped) must be turned on when manifold heaters are turned on. Failure to do so could result in generation of dangerous pressure levels in the manifold, resulting in component failure and/or sudden release of hot resin.

Pressure inside the hot runner manifold(s) can increase to dangerous levels if the nozzle and sprue heaters (if equipped) are not turned on before or at the same time as the nozzle sprue.

The pressure is generated when the injection nozzle sprue is plugged with frozen resin and the residual resin in the manifold is heated. This pressure can release suddenly causing the resin plug to eject from the sprue and hot resin to spray from the nozzle tips. The risk of serious burn injuries as a result is increased.

Moisture that infiltrates and is trapped in the hot runner molten material can also increase the risks of this potential hazard. If the temperature of the water in the molten material becomes greater than 400 °C (725 °F), the pressure of this trapped water can be significant enough to rupture the metal housing and cause serious injury to personnel.

To avoid this hazard, do the following:

1. Always make sure all nozzle and sprue heaters (if equipped) are turned on any time manifold heaters are turned on outside of the mold. The nozzle and sprue heaters can be turned on independently of the manifold heaters, however, it is recommended that they be heated first or slaved to the manifold heaters so they heat up in unison.
2. Always make sure the nozzle tips are open and the nozzle housings are dry prior to applying heat to the manifold.



IMPORTANT!

In the event of water leaking onto or into the hot runner, the nozzle tips must be removed (cold) and the plastic in the nozzles drilled out to ensure they are open to atmosphere. This can be done using a standard twist drill with the cutting edges removed to prevent damage to the melt channel.

Replace the cavity plate prior to heating the system.

2.3.3.1 Hydraulic System Pressure Hazards

- **Hydraulic System**

Flexible hose connections and piping in hydraulic systems must be properly tightened to prevent the release of fluids or gases under pressure. Hoses must be inspected periodically for signs of sweating and/or blistering. Rubber hoses naturally age with time and require replacement at regular intervals as per the manufacturer's specifications and Husky maintenance requirements. Steel tubes should be tested using dye penetrant.



WARNING!

High pressure spray hazard – risk of death or serious injury. High pressure hydraulic oil spray could penetrate human tissue and cause extensive injuries. Lock out and tag the machine before servicing any hydraulic component.



WARNING!

High pressure spray hazard – risk of death or serious injury. Depressurize each individual hydraulic circuit using an oil sampling kit before servicing any hydraulic component.

- **Skin Puncture Injuries**

High pressure hydraulic spray can penetrate human tissue and cause severe bodily injury. Seek immediate medical help in any event of skin puncture by fluid spray.

2.3.4 Electrical Hazards

- **Power Supply**

Molding equipment draws high amperage current at high voltage. The electrical power requirements are indicated on the nameplate and in the electrical schematics. Connect equipment to a suitable power supply as specified in the electrical schematics and in compliance with all applicable local regulations.

- **Water**

Water on the hot runner can be in close proximity to electrical connections and equipment. This can lead to a short circuit, resulting in serious electrical damage to the equipment. Always keep water lines, hoses, and hose fittings in good condition to avoid leaks.

2.3.5 Gas, Vapor and Dust Emissions

Certain processed materials release harmful gas, vapors or dust. Install an exhaust system according to local codes.

2.3.6 Slip, Trip or Fall Hazards

Do not walk, stand, climb or sit on machine surfaces not approved for safe access.

Do not step on the tie bar or any surfaces with grease and/or oil.

Use a safety approved platform, walkway and step ladders designated to access areas that are not accessible from the floor.

2.3.7 Lifting Hazards

When lifting equipment, use suitable lifting devices, proper balancing techniques and designated lifting points. Refer to the installation details, and to handling and lifting instructions. Do not exceed the rated capacity of the lifting equipment.

2.4 Safety Signs





Safety signs clearly mark potentially hazardous areas in or around equipment. For the safety of personnel involved in equipment installation, operation and maintenance, use the following guidelines:

- Verify that all signs are in the proper locations. Refer to the drawing package for details.
- Do not alter signs.
- Keep signs clean and visible.
- Order replacement signs when necessary. Refer to the drawing package for part numbers.







The following safety symbols may appear on safety signs:

NOTE:

Safety signs may include a detailed explanation of the potential hazard and associated consequences.

Safety Symbol (ANSI)	Safety Symbol (ISO)	General Description of Symbol
		<p>General</p> <p>This symbol indicates a potential personal injury hazard. It is usually accompanied by another pictogram or text to describe the hazard.</p>
		<p>Hazardous Voltage</p> <p>This symbol indicates a potential electrical hazard that will cause death or serious injury.</p>

Safety Symbol (ANSI)	Safety Symbol (ISO)	General Description of Symbol
		<p>High Pressure Molten Material This symbol indicates the presence of a high pressure molten material hazard that could cause death or severe burns.</p>
		<p>Lockout/Tagout This symbol identifies an energy source (electrical, hydraulic or pneumatic) that must be de-energized before maintenance is performed.</p>
		<p>Crushing and/or Impact Points This symbol indicates a crushing and/or impact area that could cause serious crushing injury.</p>
		<p>High Pressure This symbol indicates a heated water, steam or gas hazard that could cause severe injury.</p>
		<p>High Pressure Accumulator This symbol indicates the sudden release of high pressure gas or oil could cause death or serious injury.</p>
		<p>Hot Surfaces This symbol identifies the presence of exposed hot surfaces that could cause serious burn injuries.</p>
		<p>Slip, Trip or Fall Hazard This symbol indicates a slip, trip or fall hazard that could cause injury.</p>
		<p>Do Not Step This symbol identifies a location that should not be used as a step because it may be a slip, trip or fall hazard and could cause injury.</p>
		<p>Crushing and/or Shearing Hazard This symbol indicates the presence of a crushing and/or shearing hazard at the rotating screw that could cause serious injury.</p>

Safety Symbol (ANSI)	Safety Symbol (ISO)	General Description of Symbol
		<p>Read Manual Before Operation</p> <p>This symbol indicates that qualified personnel should read and understand all instructions in the equipment manuals before working on the equipment.</p>
		<p>Class 2 Laser Beam</p> <p>This symbol indicates a laser beam hazard that could cause personal injury with prolonged exposure.</p>
		<p>Barrel Cover Grounding Strap</p> <p>This symbol indicates an electrical hazard related to the barrel cover grounding strap that could cause death or serious injury.</p>
		<p>Do Not Grease</p> <p>This symbol indicates greasing is not required under normal operating conditions. Greasing could cause equipment failure.</p>

2.5 Lockout and Tagout

A lockout/tagout procedure in accordance with local codes must be performed on the machine, controller and auxiliary equipment before any maintenance activities are performed while in the machine or connected to an external energy source.



WARNING!

Complete the Lockout/Tag out of all energy sources in accordance with applicable local codes before performing maintenance activities. Failure to do so could result in serious injury or death. Refer to the machine and associated equipment manufacturer's manual for instructions.

Only qualified personnel should be permitted to install and remove locks and tags.







Lockout and tagout includes: the isolation of energy; depletion of stored energy; and prevention of re-energization from all energy sources.

2.6 Personal Protective Equipment and Safety Equipment

Personal injury can be avoided when personnel wear appropriate protective gear and use special safety equipment. The following describes the safety gear and equipment that should be used when working with the machine and any auxiliary equipment.

2.6.1 Personal Protective Equipment (PPE)

Wear appropriate personal protective equipment when working on or near equipment. Standard personal protective equipment includes:

Item	Description
	<p>Safety Glasses For protecting the eyes from flying objects/particles, heat, sparks, splash from molten material, and more.</p>
	<p>Face Shield For protecting the entire face area from flying objects/particles, heat, sparks, splash from molten material, and more.</p>
	<p>Heat Resistant Gloves For protecting the hands from extreme heats.</p>
	<p>Hearing Protection For protecting the ears from loud ambient noise.</p>
	<p>Safety Shoes For protecting the feet from electrical shocks, crushing hazards, puncture hazards, splash from molten material, and more.</p>
	<p>Non-Melting Natural Fiber Pants and Long Sleeved Shirt For protecting the body from abrasions, cuts, and potential splash from molten material.</p>

2.6.2 Safety Equipment

Use appropriate safety equipment when working on or near equipment.

Standard safety equipment includes:

- **Exhaust Fan**
For collecting potentially harmful plastic fumes
- **Purging Container**
For containing hot resin purged from the injection unit
- **Vacuum Cleaner**
For collecting spilled resin pellets and other debris that may create a falling hazard
- **Stairs and Ladders**
For ensuring safe access to areas of the machine
- **Danger Signs**
For warning other personnel to stand clear of a component or area of the machine
- **Locks and Tags**
For preventing the use of specific systems and components
- **Fire Extinguishers**
For the expedient suppression of small fires
- **Telescopic Mirror**
For safely inspecting hot runner nozzle tips from outside the mold area
- **Brass Hammers and Brass Rods**
For safely removing dried resin deposits

2.7 Material Safety Data Sheet (MSDS)



WARNING!

Chemical hazard - Some of the chemicals used with Husky equipment are potentially hazardous and could cause injury and illness. Before storing, handling, or working with any chemical or hazardous material, thoroughly read and understand each applicable Material Safety Data Sheet (MSDS), use recommended personal protective equipment and follow the manufacturer's instructions.

The Material Safety Data Sheet (MSDS) is a technical document which indicates the potential health effects of a hazardous product. It contains safety guidelines to protect personnel, as well as information about use, storage, handling, and emergency procedures.

Always refer to the applicable Material Safety Data Sheet before doing the following:

- handling a chemical product
- disassembling any portion of Husky equipment that may result in exposure to a chemical product

Contact the material supplier to obtain a copy of the MSDS sheet.

2.8 Materials, Parts and Processing

To prevent personal injury or damage to the equipment, make sure of the following:

- The equipment is only used for its intended purpose, as described in the manuals
- The operating temperatures do not exceed the specified permissible maximum value for the resin
- The maximum temperature set point is set below the flash point of the material being processed
- Lubricants, oils, process materials and tools used on equipment meet Husky specifications
- Only authentic Husky parts are used

2.9 Safety Latch Bars

All mold and hot runner assemblies are delivered with safety latch bars installed on the operator and non-operator side of the assembly.

Safety latch bars are used to hold plates together for maintenance and installation purposes. They provide a safe means for transporting and handling the assembly, and for securing plates that are normally fastened together during normal operation.



WARNING!

Crushing hazard – risk of death or serious injury. Plates could separate from each other and fall during handling if not properly secured. Under no circumstances are multiple plates to be handled with only one safety latch bar installed.

Safety latch bars must always be installed in pairs on diagonally opposite sides of the mold and hot runner assembly to provide equal pull on the plates.

NOTE:

Specific instructions on how to install safety latch bars are provided when needed in this manual.

2.10 Lift Bars and Swivel Hoist Rings

Every mold and hot runner assembly is equipped with tapped lift holes for lifting either the complete assembly or individual plates. Husky only supplies special lifting equipment (including a lift bar and swivel hoist rings) when required. This lifting equipment is designed specifically for the mold/hot runner assembly. When Husky provides special lifting equipment, use only Husky specified and supplied lifting equipment.

NOTE:

Separate lift bars for the hot and cold halves of the mold and hot runner assembly may be provided based on the requirements of the assembly.



IMPORTANT!

Make sure all lifting equipment is rated for the load and in safe operating condition. Follow the recommendations and use care when moving or handling plates or assemblies.

For instructions about lifting plates and plate assemblies and using the Husky provided lift bar and swivel hoist rings, refer to [Section 4.1](#).

NOTE:

The Husky provided lift bar, swivel hoist rings and associated hardware must be stored together while the mold, hot runner, tooling plate and CoolPik plate are in operation.

Chapter 3 Specifications

This chapter outlines the necessary temperature, electrical, air and lubricant information needed to operate and maintain the manifold system.

3.1 Weight

The full weight of the manifold system assembly is listed on the assembly drawings.

3.2 Operating Temperature

The hot runner must operate within a specific temperature range to prevent internal resin leakage and damage to internal components as the result of thermal expansion. This temperature range is listed on the hot runner nameplate as the temperature difference between the manifold and the mold.



IMPORTANT!

The temperature range is critical for the hot runner system to be able to create a proper seal. It is important the designed operating temperature window be observed at all times.

For more information about the nameplate, refer to [Section 1.7.1](#).

3.3 Electrical System Specifications

Refer to the electrical schematic for the following information:

- Control zones
- Multi-pin connector and pin positions for each heater and thermocouple wire
- Connecting heater wiring in parallel (if applicable)
- Amperage, wattage and resistance of each heater
- Keypin locations

3.3.1 Controller Requirements

The number of control zones required for the heaters will depend on the size and requirements of the basic system.



DANGER!

Electrical hazard – risk of serious injury, fire and/or overload of electrical components. Do not use a controller with an amperage rating less than that required by the heaters. Do not use a controller with a higher amperage rating than the connectors or cables to the hot runner.

The type of controller can be either:

- Automatic control using a thermocouple to sense the nozzle tip temperature
- Manual control where the controller is set to provide power during a percentage of time

There may be an optional switchbox for turning ON or OFF the power to individual nozzle heaters.

NOTE:

The controller output to the heaters must be set to 220 to 240 V, 50 to 60 Hz single phase.

3.3.2 Nozzle Heaters

The nozzle heaters can be controlled separately or in zones by manual controllers. Refer to the electrical schematic for the correct configuration.

3.3.3 Manifold Heaters

Whenever possible, the manifold heaters are wired in parallel and controlled by a single controller zone. The circuit will be completed either at the cable connector or at the manifold.

The heaters are connected in multiple zones if the total amperage of all the heaters connected in parallel exceeds the capacity of a single controller zone.

Each zone is connected to a separate controller zone with its own thermocouple.

3.3.3.1 Spare Thermocouple Wires

The temperature of each manifold heater zone is sensed by a J-type thermocouple.

NOTE:

Special order thermocouples may be other types.

A spare thermocouple for each zone is also be routed to the base of the multi-pin connector to minimize down time. Should the main thermocouple fail, the spare can be easily connected without having to disassemble the mold. The failed thermocouple can be replaced at the next maintenance interval.

The spare thermocouples can also be used to verify the condition of the first thermocouple should a sensing problem develop.

NOTE:

To establish proper polarity when connecting thermocouples, follow the electrical schematic. For J-type thermocouples, the white wire is positive (+) and the red wire is negative (-). This wire color coding follows the ANSI J-Type North American Standard. The color coding and wire composition for J-type thermocouples in other parts of the world may be different and produce different readings.

3.3.4 Power Fluctuation

Hot runner systems are sensitive to fluctuations in power supply voltage. The nozzle and manifold heaters are rated for 240 V (or 200 V in special applications).

NOTE:

Always refer to the hot runner nameplate on the operator's side of the clamp before installing a hot runner. For more information on the nameplate, refer to [Section 1.7](#).

The manifold is always controlled by thermocouples and will compensate for minor voltage fluctuations.

Where the nozzle heaters are regulated by percentage timers, the heat output will be directly affected by voltage fluctuations. For example, a reduction of the voltage by only 10% will affect output (in Watts) by approximately 20%, which will reduce the nozzle temperatures considerably. Adjustment is required.

In severe cases where the stability of the power supply is known to be unreliable, it may be advisable to install an automatic voltage stabilizer rated for the power requirements of the controller.

3.4 Operating Specifications

The operating specifications depend on the type of manifold being used.

3.4.1 Hydraulic Manifold Operating Limits

Fluid Type	Description	Value
Hydraulic fluid	Maximum operating pressure	40 bar (580 psi) - 50 bar (725 psi) ^[1]
	Maximum operating flow rate	9.5 L/min (2.5 U.S. gal./min)
Cooling water	Maximum operating pressure	8 bar (116 psi)
	Minimum operating flow rate	2 L/min (0.53 U.S. gal./min) per actuator
	Maximum water temperature	35 °C (95 °F)

^[1] The hydraulic fluid maximum operating pressure depends on the size of the Unify System.

3.4.2 Pneumatic Manifold Operating Limits

	Description	Value
Air	Maximum operating air pressure	12.5 bar (180 psi)
	Air must be filtered and conditioned according to Section 3.6	
Cooling water	Maximum operating pressure	8 bar (116 psi)
	Minimum operating flow rate	2 L/min (0.53 U.S. gal./min) per actuator
	Maximum water temperature	90 °C (194 °F)
	Use of thermal regulator for melt temperatures	> 290 °C (554 °F)

3.5 Hydraulic Fluid Specifications

Hydraulic pressure is used to actuate the valve stems. The system must meet the following requirements:

- Hydraulic fluid must be filtered using a continuous inline filter system and changed every 2,000,000 cycles.
- Hydraulic oil filtration to class 20/18/15 ISO 4406 standards
- Make sure that the pump controlling the hydraulic pressure is connected to the emergency stop of the molding machine to relieve the pressure during an e-stop condition.
- The temperature rating of the hydraulic fluid must exceed the melt temperature of the system.

3.6 Pneumatic Specifications

Pneumatic pressure is used to actuate the valve stems. Compressed air for the pneumatic system must meet the following requirements:

- The pressure dew points must be set to 11 °C (20 °F) below the lowest ambient temperature of the pneumatic system in order to keep compressed air clean and dry.
- Compressed air quality must meet the standards specified in DIN ISO 8573-1.
 - Solid particles - Class 1
 - Humidity - Class 4
 - Oil - Class 1

- Typical air pressure required is 5.52 to 8.27 bar (80 to 120 psi) , unless otherwise specified in the mold manufacturer's documentation.

NOTE:

For many pneumatic VG applications, air pressure of 7 bar (100 psi) may be sufficient, while some applications may require up to 12.5 bar (180 psi) for optimal and stable performance.

- Compressed air hoses must be large enough to permit adequate flow to the locations where air is required.
- Compressed air used for mold actuators must be interlocked with the machine operator's gate, so opening the gate prevents any motion.
- Quick exhaust valves must be located close to the actuators they control, so the compressed air in the mold will decompress rapidly and speed operation of the actuator.
- Lockout valves must be installed (according to ANSI Z244.1 or local regulations) to the air supply for use when:
 - Serving the mold
 - Performing maintenance
 - Installing and removing the mold

3.7 Hydraulic Cooling Water Specifications

Description	Value
Maximum temperature at inlet	35 °C (95 °F)
Maximum pressure	8 bar (116 psi)
Maximum number of actuators per cooling circuit and/or maximum temperature at outlet	3 actuators
	40 °C (104 °F)

3.8 Pneumatic Cooling Water Specifications

Description	Value
Maximum temperature at inlet	90 °C (194 °F)
Maximum pressure	8 bar (116 psi)
Maximum number of actuators per cooling circuit and/or maximum temperature at outlet	3 actuators
	40 °C (104 °F)

3.9 Recommended Lubricants

The following are recommended lubricants to be used during the assembly and maintenance of Husky hot runners:

NOTE:

Husky recommends only the following lubricants and assumes no responsibility for lubricants not specified. It is the customer's responsibility when consulting with an alternate supplier to make sure a suitable equivalent is used.

NOTE:

Lubricants of inferior quality can cause premature wear of components.

**WARNING!**

Chemical hazard - Some of the chemicals used with Husky equipment are potentially hazardous and could cause injury and illness. Before storing, handling, or working with any chemical or hazardous material, thoroughly read and understand each applicable Material Safety Data Sheet (MSDS), use recommended personal protective equipment and follow the manufacturer's instructions.

CAUTION!

Contamination hazard – risk of contaminating lubricants or greases. Do not mix different brands or grades of lubricants or greases. Mixing lubricants or greases can cause premature breakdown of the lubricant or grease and could result in equipment damage.

**WARNING!**

Poison hazard – risk of death or serious injury. Some recommended lubricants may contain toxic and/or non-ingestible additives and may not be Food and Drug Administration (FDA) approved under the United States Department of Agriculture (USDA) rating H1 (formerly AA). Consult with the lubricant manufacturer for specific details.

Type/ Description	Trade Name	Part Number	Quantity	Used For
Static application Grease	Kem-A-Trix Fahrenheit 800 Bearing Gel	3936720	113 g (4 oz) Squeeze Tube	Guide pins, alignment dowels, screw heads and threads, O-ring seals ^[2]
		3936725	397 g (14 oz) Grease Gun Tube	
High temperature Anti-seize lubricant	Loctite Nickel Anti- Seize 771	5541918	225 g (8 oz) Can	Screws installed into the manifold
Protective spray	LPS 2 Lubricant	1501808	566 g (20 oz) Non- Aerosol Spray Bottle	Hot runner plates
Thread-locking fluid	Loctite 248	5541916	9 g (0.32 oz) Glue Stick	Screws that secure the manifold

^[2] Apply only as directed. Refer to maintenance procedures and/or assembly drawings for more information.

3.10 Rust Inhibitor Specifications

Any rust inhibitor used on the mold must meet the following specifications:

Type	Trade Name
Protective Spray	LPS 2 Protective Spray

3.11 Torque Specifications

Torque specifications are provided on the assembly drawings.

CAUTION!

Mechanical hazard – risk of damage to the hot runner. Use of improper torque can result in equipment damage. Always consult the assembly drawings for torque specifications.

3.12 Hydraulic and Pneumatic Actuator Component Specifications

The following tables contain the component descriptions and quantities for the large and small Hydraulic and Pneumatic actuators.

3.12.1 Large Hydraulic Actuator Components

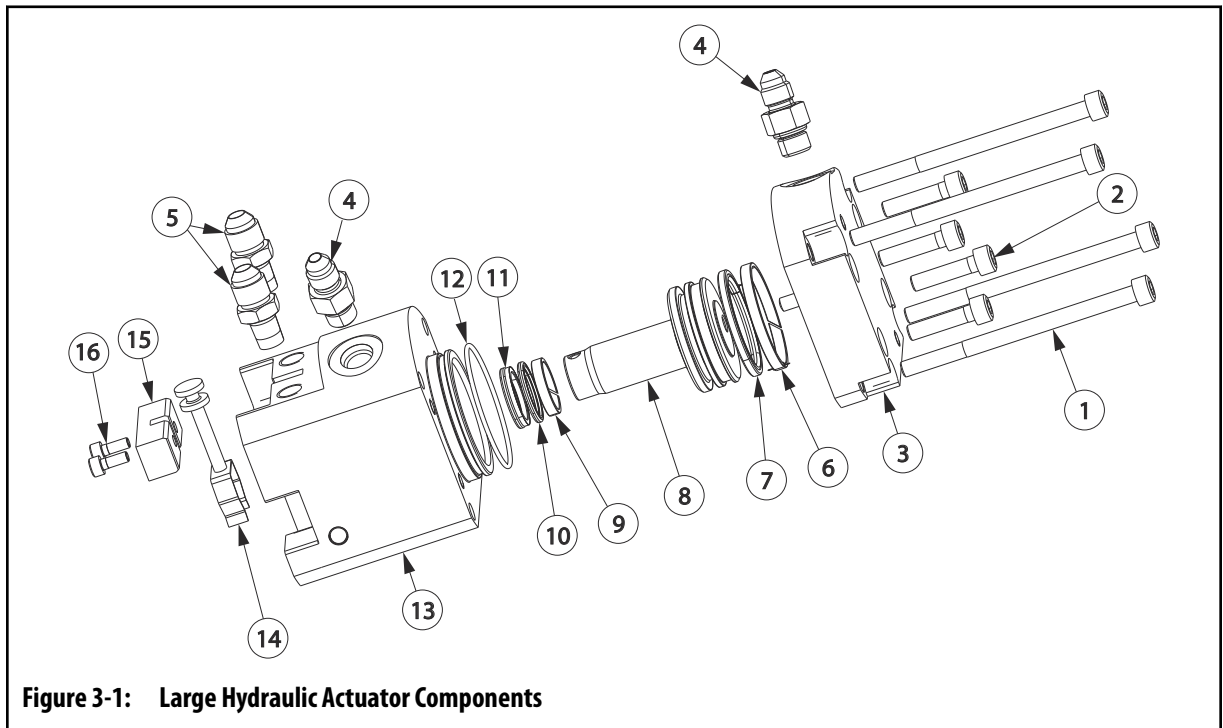

Figure 3-1: Large Hydraulic Actuator Components

Table 3-1: Large Hydraulic Actuator Components

Item	Component Description	Quantity
1	SHCS M6 x 90 mm (3.5 in)	4
2	SHCS M6 x 25 mm (1 in)	4
3	Cylinder cap	1
4	Adapter fitting JIC AN4 to NPT for hydraulic	2
5	Adapter fitting JIC AN5 to NPT for water	2
6	Wear Ring Piston	1
7	Piston Seal	1
8	Piston	1

Table 3-1: Large Hydraulic Actuator Components (Continued)

Item	Component Description	Quantity
9	Wear Ring Cylinder	1
10	Rod Step Seal	1
11	Scraper Seal	1
12	O-Ring	1
13	Cylinder	1
14	Spring Pin S/A	1
15	Stop Block	1
16	SCHS M4 X 10 mm (0.40 in)	2

3.12.2 Small Hydraulic Actuator Components

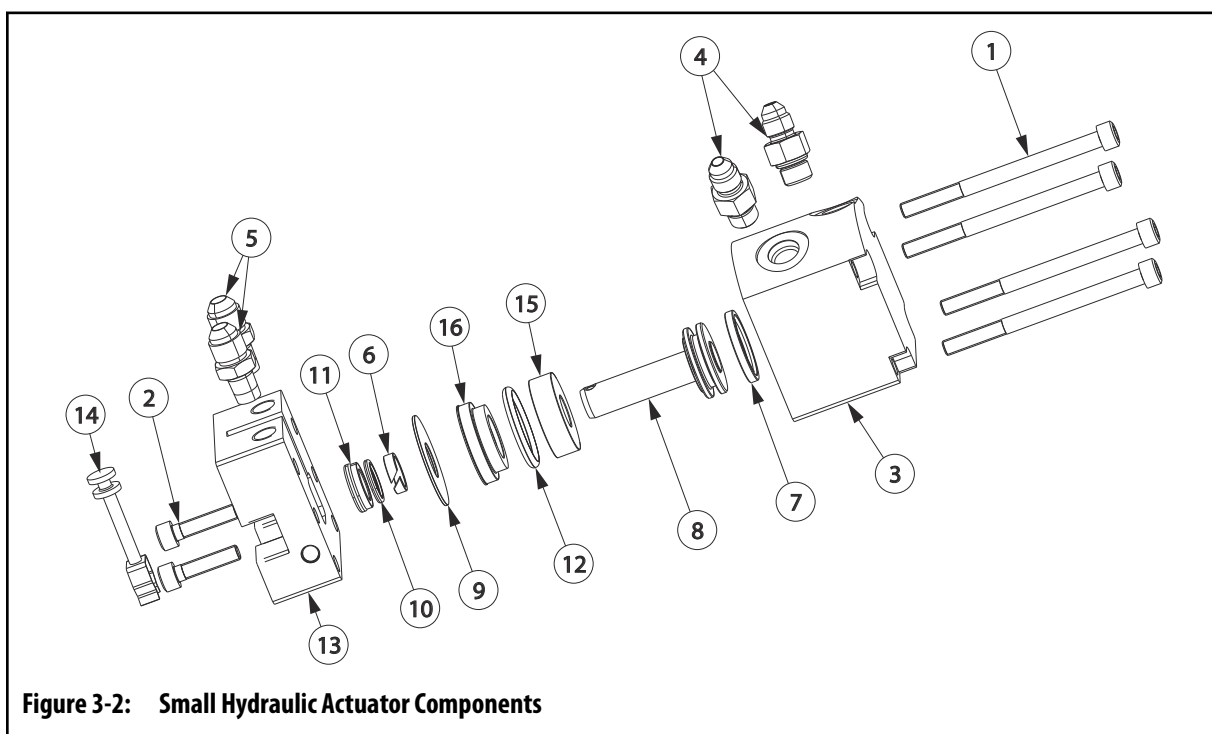
**Figure 3-2: Small Hydraulic Actuator Components****Table 3-2: Small Hydraulic Actuator Components**

Item	Component Description	Quantity
1	SHCS M6 x 80 mm (3.15 in)	4

Table 3-2: Small Hydraulic Actuator Components (Continued)

Item	Component Description		Quantity
2	SHCS M6 x 25 mm (1 in)		2
3	Cylinder	Standard Stroke	1
		Short Stroke (APP)	1
4	Adapter fitting JIC AN4 to NPT for Hydraulic		2
5	Adapter fitting JIC AN5 to NPT for Water		2
6	Wear Ring		1
7	Piston Seal		1
8	Piston	Standard Stroke	1
		Short Stroke (APP)	1
9	Seal Cap		1
10	Step Seal		1
11	Scraper Seal		1
12	O-Ring		1
13	Cylinder Base	Standard Stroke	1
		Short Stroke (APP)	1
14	Spring Pin S/A		1
15	Seal insert		1
16	Seal insert		1

3.12.3 Large and Small Pneumatic Actuator Components

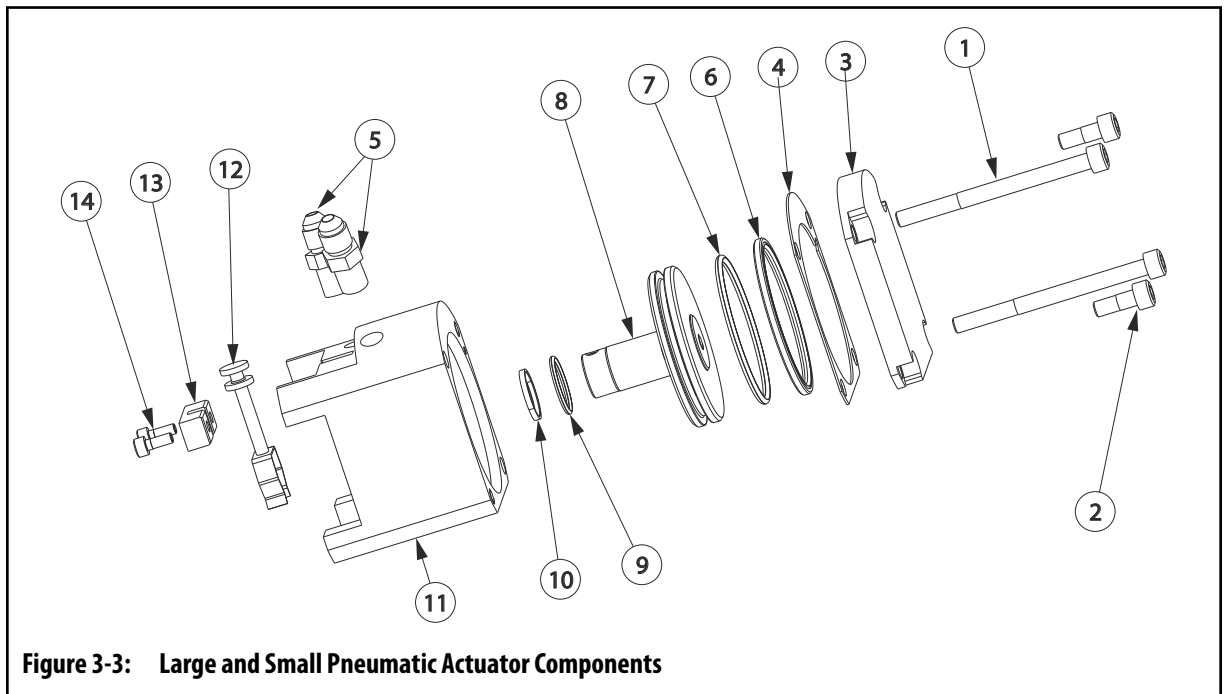

Figure 3-3: Large and Small Pneumatic Actuator Components

Table 3-3: Large and Small Pneumatic Actuator Components

Item	Component Description	Actuator Size	Quantity
1	SHCS M6 x 75 mm (2.95 in)		2
2	SHCS M6 x 16 mm (0.63 in)		2
3	Cylinder Cap	Small	1
		Large	1
4	Gasket	Small	1
		Large	1
5	Adapter fitting JIC AN4 to NPT for Air		2
6	Piston Seal	Small	1
		Large	1
7	O Ring	Small	1
		Large	1
8	Piston	Small	1
		Large	1

Table 3-3: Large and Small Pneumatic Actuator Components (Continued)

Item	Component Description	Actuator Size	Quantity
9	GLYD Ring		1
10	O Ring		1
11	Cylinder	Small	1
		Large	1
12	Spring Pin S/A		1
13	Stop Block	Small	1
		Large	1
14	SHCS M4 x 10 mm (0.39 in)		2

3.12.4 Large and Small Pneumatic Actuator with Thermal Regulator Components

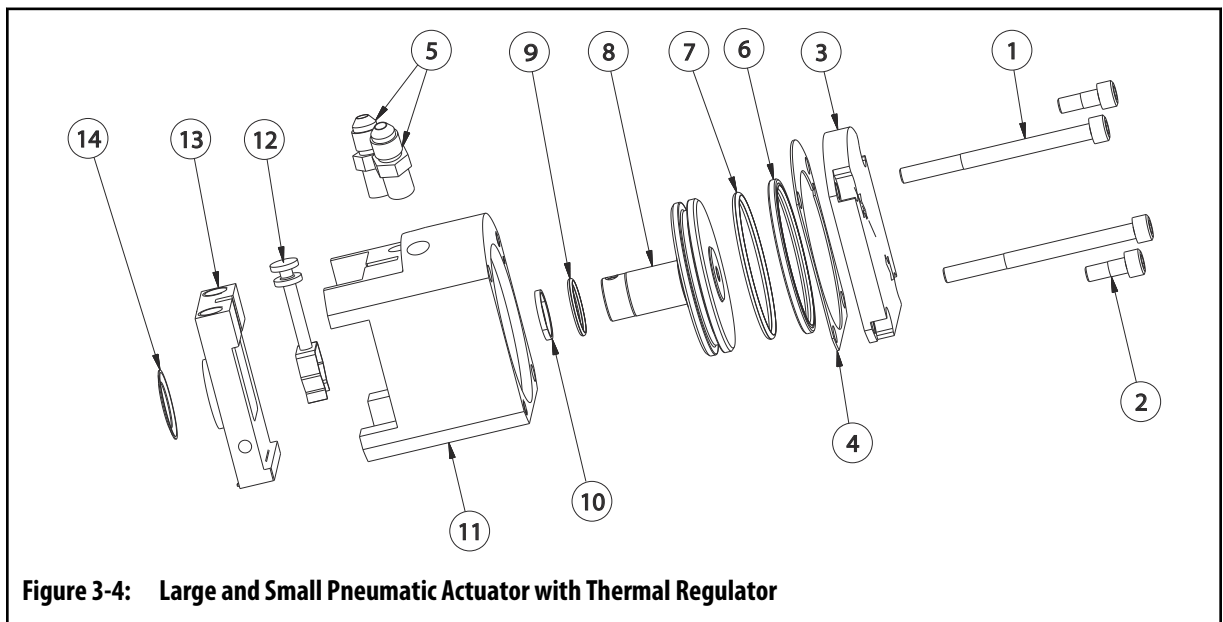

Figure 3-4: Large and Small Pneumatic Actuator with Thermal Regulator

Table 3-4: Large and Small Pneumatic Actuator with Thermal Regulator Components

Item	Component Description	Actuator Size	Quantity
1	SHCS M6 x 75 mm (2.95 in)		2
2	SHCS M6 x 16 mm (0.63 in)		6

Table 3-4: Large and Small Pneumatic Actuator with Thermal Regulator Components (Continued)

Item	Component Description	Actuator Size	Quantity
3	Cylinder Cap	Small	1
		Large	1
4	Gasket	Small	1
		Large	1
5	Adapter fitting JIC AN4 to NPT for Air		2
6	Piston Seal	Small	1
		Large	1
7	O Ring	Small	1
		Large	1
8	Piston	Small (12.4 mm stroke)	1
		Large (13.58 mm stroke)	1
9	GLYD Ring		1
10	O Ring		1
11	Cylinder	Small	1
		Large	1
12	Spring Pin S/A		1
13	Thermal Regulator	Small	1
		Large	1
14	Disc Spring	Small	1
		Large	1

Chapter 4 Installation and Removal

This chapter describes how to install and remove the hot runner assembly.



IMPORTANT!

The procedures contained in this chapter were written for a standard hot runner and do not take special options into consideration.

4.1 Lifting and Handling

The following procedures describe how to safely lift plates and plate assemblies.

CAUTION!

Mechanical hazard – risk of damage to the hot runner. Do not lift plates using magnetic lifting devices. These devices could potentially scratch a finely ground plate.



IMPORTANT!

Safety must be the primary consideration when lifting and moving a plate. Make sure to always use suitable lifting equipment that is inspected regularly and follow the recommendations outlined in this manual.



IMPORTANT!

Every mold and hot runner assembly is equipped with tapped lift holes for lifting either the complete assembly or individual plates. Husky only supplies special lifting equipment (including a lift bar and swivel hoist rings) when required. This lifting equipment is designed specifically for the mold/hot runner assembly. When Husky provides special lifting equipment, use only Husky specified and supplied lifting equipment. Use Husky special lifting equipment to lift only the designated mold or hot runner or component.



WARNING!

Crushing hazard – risk of death or serious injury. Inadequate lifting equipment could fail and cause death or serious injury. Use only Husky specified or supplied lifting equipment.



WARNING!

Crushing hazard – risk of death or serious injury. Misuse of lifting equipment could lead to equipment failure and cause death or serious injury. Use Husky only specified or supplied lifting equipment for lifting the assembly or the component for which the equipment has been designated by Husky.

4.1.1 Lifting and Handling Using a Single Lifting Point

The following procedures describe how to lift and lower plates using a single lifting point.

4.1.1.1 Laying Down Plates Using a Single Lifting Point

To properly lay a plate on a work surface using a single lifting point, do the following:



WARNING!

Crushing hazard – risk of death or serious injury. Inadequate lifting equipment can fail and could cause death or serious injury. Make sure all lifting equipment is rated for the load and in safe operating condition.

1. Install a lift bar or swivel hoist ring and connect it to an overhead lifting device.
 - For information about lifting using a lift bar, refer to [Section 4.1.3](#).
 - For information about lifting using swivel hoist rings, refer to [Section 4.1.4](#).
2. Lift the plate above the work surface.

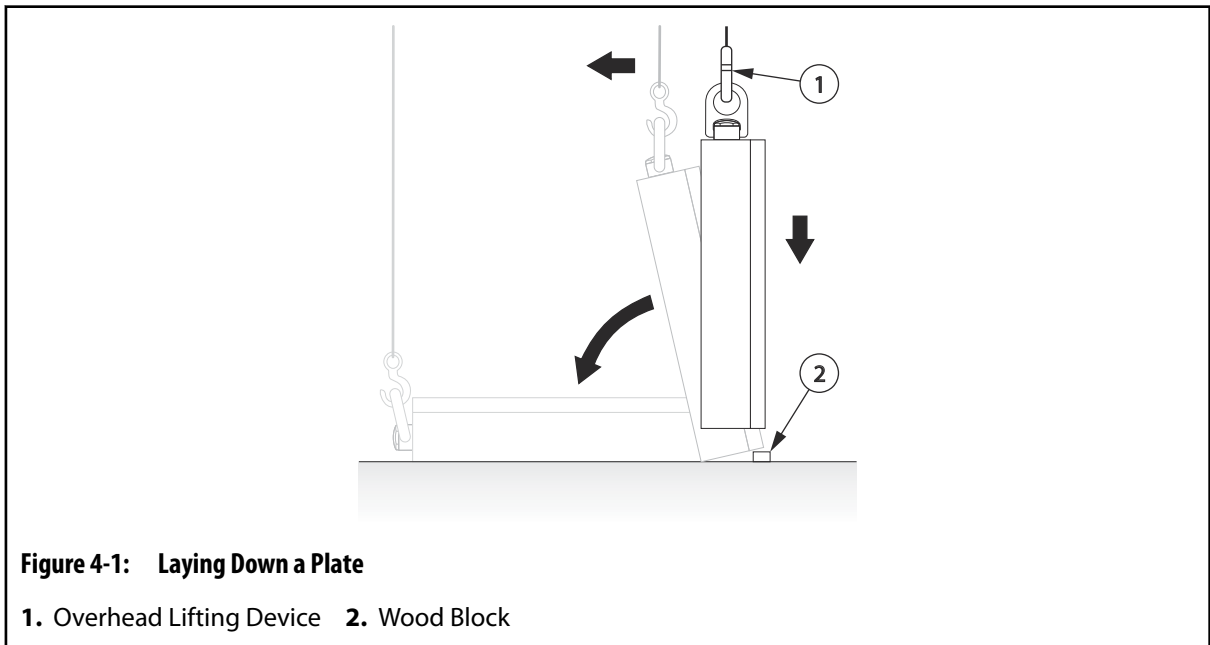

3. Secure a wood block to the work surface on the side opposite the area where the plate will be laid down.

4. Lower the plate slowly onto the edge of the secured wood block.
5. Continue to slowly lower the plate until it tips over towards the work surface.
6. Lay the plate down on the work surface.

4.1.1.2 Picking Up Plates Using a Single Lifting Point

When lifting a plate that has been laid down using a single lifting point, the lifting device may go slack just as the load is in its full vertical position. This may cause the plate to swing over-center in the opposite direction.

To prevent this from happening, do the following:



WARNING!

Crushing hazard – risk of death or serious injury. Inadequate lifting equipment can fail and could cause death or serious injury. Make sure all lifting equipment is rated for the load and in safe operating condition.

1. Install a lift bar or swivel hoist ring and connect it to an overhead lifting device.
 - For information about lifting using a lift bar, refer to [Section 4.1.3](#).
 - For information about lifting using swivel hoist rings, refer to [Section 4.1.4](#).
2. Secure a wood block to the work surface near the foot of the plate. This will prevent the plate from going over-center.

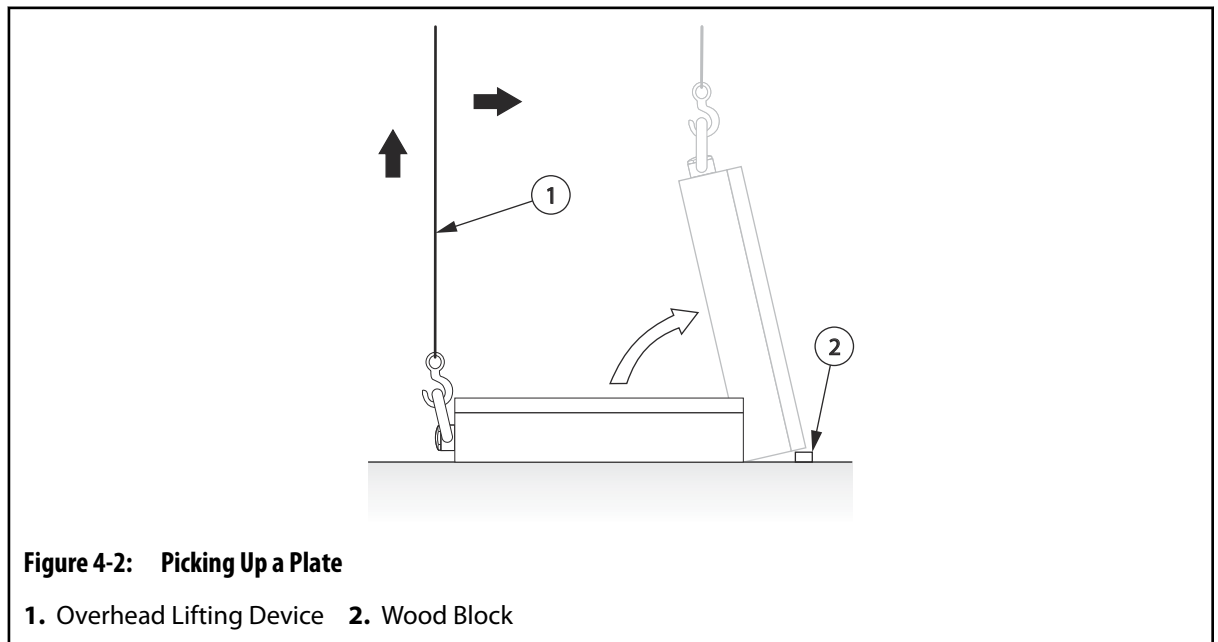

3. Lift the plate until it touches the secured wood block.



WARNING!

Impact hazard – risk of serious injury. The plate could swing in a pendulum motion just as the plate is lifted off of the wood block. Lift slowly to reduce the pendulum motion. Stand clear of the possible swing area to prevent injury.

4. Continue to lift the plate, keeping the tension on the lifting cable.

CAUTION!

Mechanical hazard – risk of damage to equipment. When storing the plate, make sure it is secured in the vertical or horizontal position. Do not rest the plate against another object.

5. After the plate has stabilized, move it to a safe location and remove the wood block.

4.1.2 Lifting and Handling Using Multiple Lifting Points

To lift a plate using more than one lifting point, do the following:



WARNING!

Crushing hazard – risk of death or serious injury. Inadequate lifting equipment can fail and could cause death or serious injury. Make sure all lifting equipment is rated for the load and in safe operating condition.

1. Install the swivel hoist rings in the designated lifting points. Make sure the swivel hoist rings are positioned on opposite sides of the plate to evenly distribute the weight when the plate is lifted vertically.

For information about lifting using swivel hoist rings, refer to [Section 4.1.4](#).

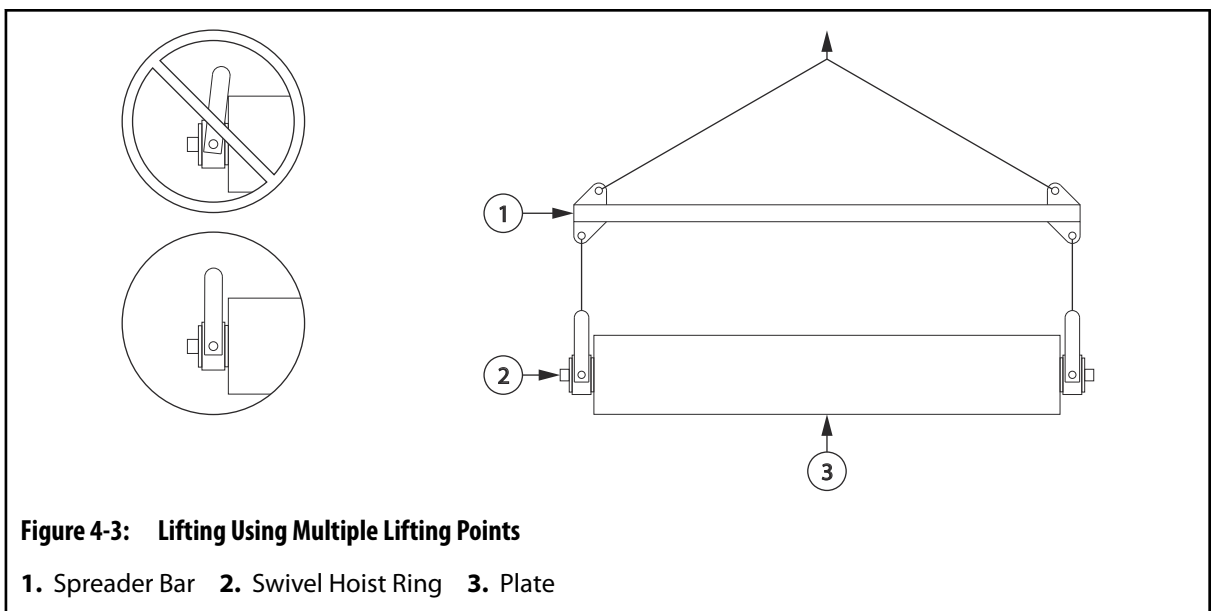

2. Connect the swivel hoist rings to an overhead lifting device. Use a spreader bar if either of the following conditions occur:
 - The pivot angle of any swivel hoist ring exceeds 90°.
 - The angle of lifting cables, slings or chains is less than 45°.
3. Lift the plate and move it to a safe location.

4.1.3 Lifting Using a Lift Bar

To properly lift plates and assemblies using a lift bar, do the following:

NOTE:

For the installation locations of the lift bars, refer to the hot runner for the markings “Lift Bar Only” or to the assembly drawings.

NOTE:

The maximum weight the bar can lift is stamped on the Husky lift bar. If using a lift bar that is not provided by Husky, make sure the lift bar is suitably rated for the weight of the mold/hot runner assembly.

1. Install the lift bar to the lifting holes on the top of the component.

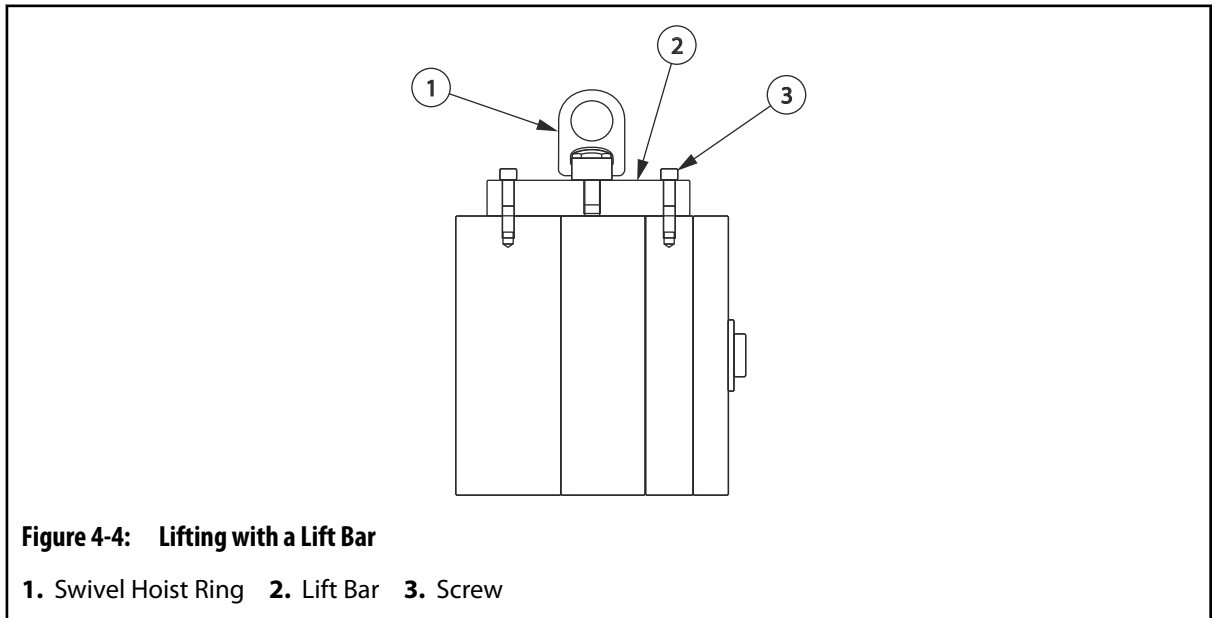

2. Torque the hoist ring to the specified value. Refer to [Section 3.11](#) for torque requirements.
3. Attach a suitable overhead lifting device to the swivel hoist ring and lift the plate or plate assembly vertically.
4. While the mold and hot runner are in operation, store the Husky provided lifting equipment together and in a readily accessible area.

4.1.4 Lifting Using Swivel Hoist Rings

When using swivel hoist rings, remember the following:

- For the installation locations of the swivel hoist rings, refer to the hot runner for the markings “Hoist Ring Only” or to the assembly drawings.
- Always make sure the swivel hoist ring is properly torqued before lifting.
- Make sure the swivel hoist ring used can support the weight of the plate or component at the chosen angle of attack.
- Do not lift more than the rated capacity.
- Depending upon the sling angle, the applied load may be more than the weight being lifted. Two point lifting of a 1000 kg (2000 lb) weight, with a sling angle of 30°, will result in an applied load of 1000 kg (2000 lb) to each hoist ring.
- After installation, make sure the hoist ring swivels and pivots freely in all directions. The side of the ring must not contact anything.
- After installation and during operation, store the Husky provided lifting equipment together and in a readily accessible area.
- Never use a hook or other lifting device which will pry or open the “U” shaped bar on center-pull hoist rings.
- Screws must be tightened to the recommended torque values.
- Do not apply shock loads. When lifting, apply force gradually.
- Do not use spacers between the hoist ring bushing and the work piece surface.
- The work piece surface must be flat, providing complete contact for the hoist ring bushing.

Metric and Imperial swivel hoist rings are available through your nearest Husky Parts Distribution Center.

Swivel hoist rings purchased from other suppliers must meet or exceed the following specifications.

Table 4-1: General Hoist Ring Specifications

Category	Specification
Material	4140 certified aircraft quality
Type	Forged hoist ring
Finish	Phosphate per DOD-P-16232F
Safety Factor	5:1
Swivel	Pivot 180° and swivel 360°
Thread	ISO 261 and ISO 965 - Coarse
Surface	Magnetic particle inspected (ASTM E709-80)
Certification	Individual certificate of conformance with the serial number specified on the hoist ring for traceability

Table 4-2: Specifications for Metric Coarse Swivel Hoist Rings

Part Number	Rated Capacity ^[1]	Torque	Thread Ø	Minimum Full Thread Depth	Pitch
2761800	1050 kg (2315 lb)	37 N·m (27 lbf·ft)	M12	24	1.75
2770570	1900 kg (4189 lb)	80 N·m (59 lbf·ft)	M16	32	2.00
2502267	4200 kg (9259 lb)	311 N·m (229 lbf·ft)	M24	48	3.00
536013	7000 kg (15432 lb)	637 N·m (470 lbf·ft)	M30	60	3.50
2761801	11000 kg (24250 lb)	1085 N·m (800 lbf·ft)	M36	72	4.00
2761803	12500 kg (27558 lb)	1085 N·m (800 lbf·ft)	M42	84	4.50

^[1] Minimum rated capacity at any pull angle (between 0° horizontal pull and 90° vertical pull)

Table 4-3: Specifications for Inch UNC Swivel Hoist Rings

Part Number	Rated Capacity ^[2]	Torque	Thread Ø	Minimum Full Thread Depth	Pitch
2732764	1130 kg (2500 lb)	38 N·m (28 lbf·ft)	1/2	1.0	13
2732765	2260 kg (5000 lb)	135 N·m (100 lbf·ft)	3/4	1.5	10
2760517	4530 kg (10000 lb)	310 N·m (229 lbf·ft)	1	2.0	8
2732766	6800 kg (15000 lb)	640 N·m (472 lbf·ft)	1 1/4	2.5	7
2732767	10880 kg (24000 lb)	1080 N·m (797 lbf·ft)	1 1/2	3.0	6

^[2] Minimum rated capacity at any pull angle (between 0° horizontal pull and 90° vertical pull)

4.2 Installing and Removing the Manifold Assembly

Use the following procedures to install and remove the Unify manifold assembly to the mold.

4.2.1 Installing the Manifold into the Plates

To install the Unify manifold into the plates, do the following:

1. Install the assembly guide rods into the tapped holes in the manifold plate pocket. Refer to the assembly drawing for the location of the tapped holes.
2. Install hoist rings to the designated lifting points on the manifold face. Refer to the assembly drawing for the location of the lifting points.
3. Attach the hoist rings to an overhead lifting device and lift the manifold only until the lifting chain has a slight tension on it.

4. Disconnect the overhead lifting device and remove the hoist rings from the manifold.
5. Install the screws that secure the manifold to the plate. Each drop has four screws surrounding it.

**IMPORTANT!**

Torque the screws that secure the manifold to the plate as specified in the assembly drawings. Do not over-torque the screws.

6. Starting from the drop closest to the center of the manifold, use a cross-pattern to hand tighten the screws, then repeat the same cross-pattern to torque the screws to half the torque value listed in the assembly drawing. Refer to [Figure 4-5](#).
 7. Repeat the same cross-pattern used in [step 6](#) to torque the screws to the full torque value listed in the assembly drawing. Make sure all screws are tightened to a uniform torque value.
-

NOTE:

It is recommended to go around the cross-pattern two to three times, torquing each drop screw, to make sure all of the screws are at the specified torque value. Keep going around the cross-pattern until there is no longer any rotation of the screws at the specified torque value.

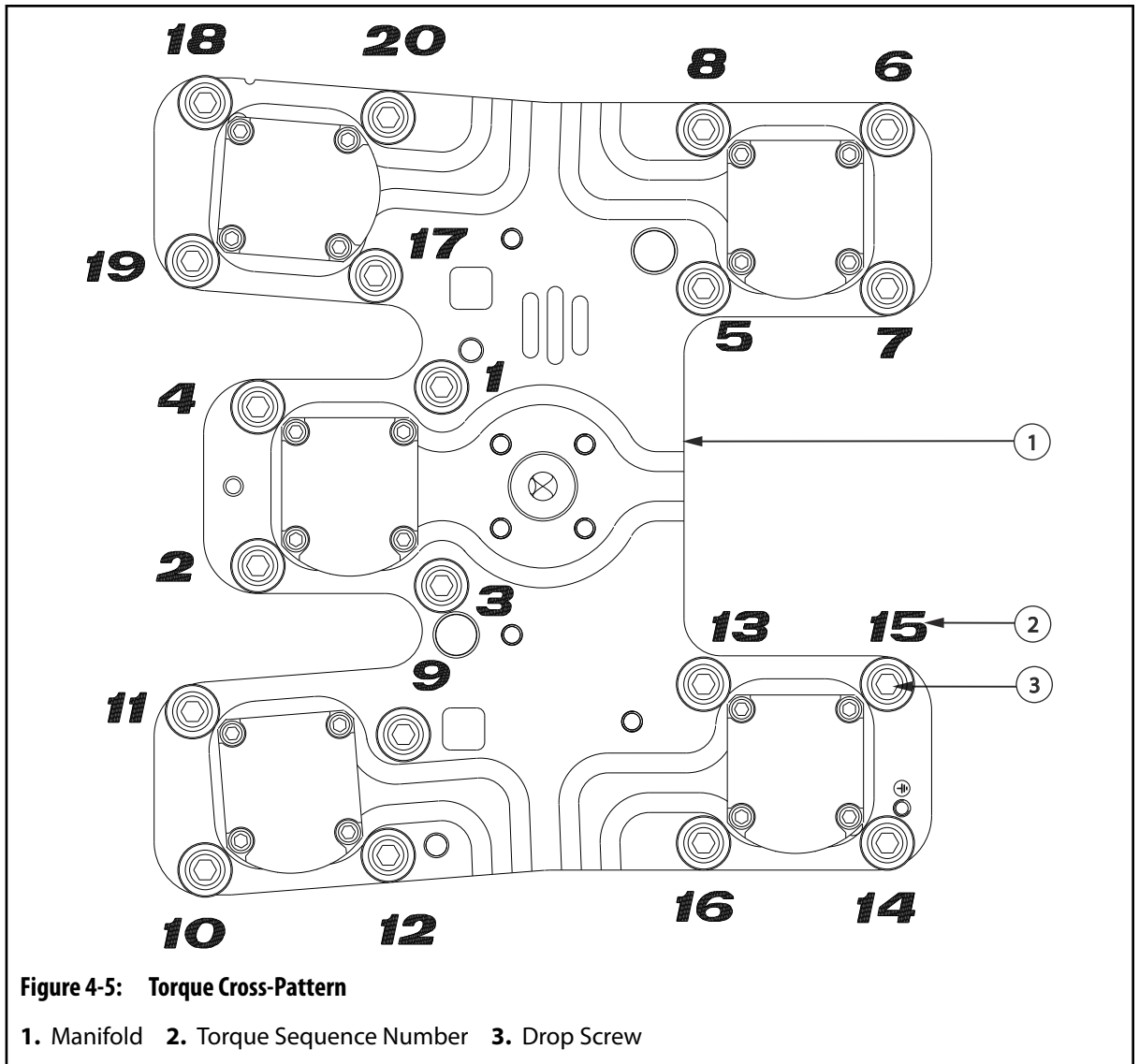

- 8. If desired, add hold down screws (M6 or 1/4 - 20) to each mounting tab on the unify frame and torque to the specified values.



IMPORTANT!

For cross Manifold design, make sure that the alignment pull dowels that keep the cross and main manifolds aligned during assembly, shipping, and installation are removed. Assembly dowels should be re-installed if manifolds are removed and serviced.

NOTE:

Hold down screws are optional. Husky does not provide the hold down screws.

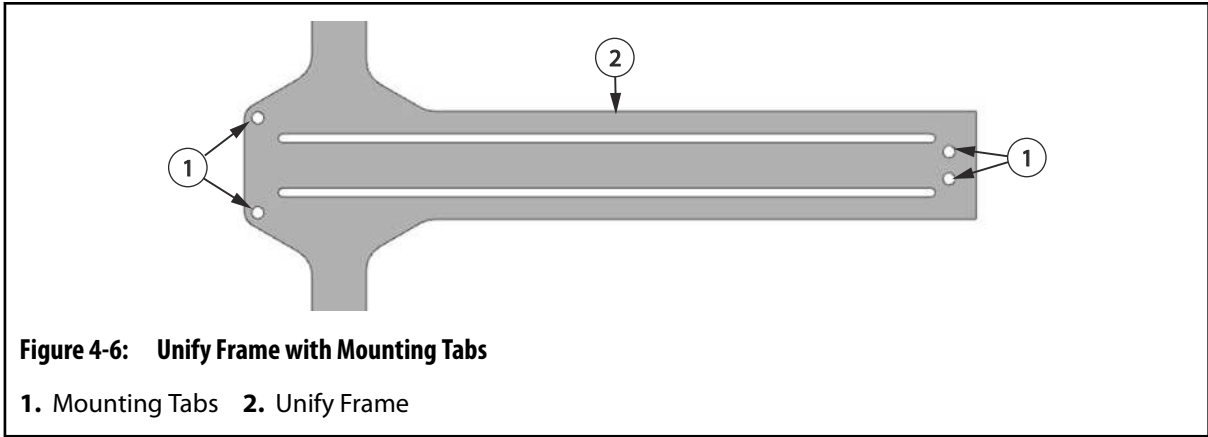

4.2.2 Removing the Manifold assembly from the Mold

To remove the Unify manifold assembly from the mold, do the following:

1. Lock out and tag the machine. Refer to [Section 2.5](#) for more information.
2. For a hydraulic manifold, disconnect the hydraulic and cooling hoses to the manifold. For a pneumatic manifold, disconnect the air and cooling hoses (if equipped) to the manifold.
3. Disconnect the electrical cables to the manifold.
4. Remove the mold from the machine. Refer to the machine and mold manufacturer’s manual for more information.
5. Remove the screws securing the manifold assembly to the mold.



IMPORTANT!

Do not lift the system using side mounted holes or from the wire and hose management channels.

6. If required, remove the hold down screws (M6 or ¼ - 20) from each mounting tab on the unify frame.

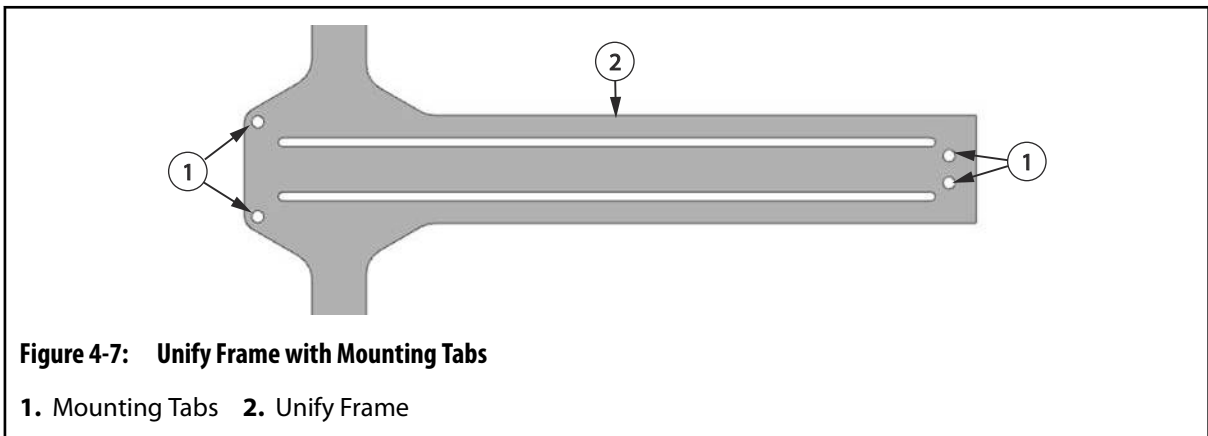

7. Install hoist rings into the designated lifting points on the manifold assembly. Refer to the assembly drawing for the location of the lifting points.

**WARNING!**

Crushing hazard – risk of death or serious injury. Inadequate lifting equipment can fail and could cause death or serious injury. Make sure all lifting equipment is rated for the load and in safe operating condition.

8. Attach an overhead lifting device to the hoist rings and lift only until the lifting chain has a slight tension on it.
-

CAUTION!

Mechanical hazard – risk of damage to equipment. When storing the hot runner, make sure it is secured in the vertical or horizontal position. Do not rest the assembly against another object.

CAUTION!

Mechanical hazard – risk of damage to the hot runner. The hot runner must be set on supports if it is laid down horizontally, such as on a work bench. Damage to the nozzle tips, sprue bushing and/or wires could occur.

9. Move the manifold assembly to a safe location.
 10. Remove the hoist rings from the designated lifting points on the manifold assembly.
-

Chapter 5 Startup and Operation

This chapter describes how to safely startup and operate the hot runner. Follow these instructions along with any in the machine manufacturer's documentation.

NOTE:

If the hot runner is installed in a Husky machine, refer to the startup instructions in the machine manufacturer's documentation.

To startup the hot runner for operation, perform the following procedures in order:

Step	Task	Reference
1	Prepare the hot runner	Section 5.1
2	Heat up the mold, hot runner and machine	Section 5.2
3	Precharge the hot runner with resin	Section 5.3
4	Produce test parts	Section 5.4



IMPORTANT!

The mold and hot runner must be installed properly by qualified personnel before production begins.

5.1 Preparing the Hot Runner

To prepare the hot runner for startup, do the following:

1. Lock out and tag the machine and controller (if equipped). Refer to [Section 2.5](#) for more information.
2. Make sure the mold and hot runner are installed properly.
3. Make sure the heaters and thermocouples are connected to the machine or a controller.
4. Make sure the resin type in the machine matches the required type indicated on the hot runner nameplate. Refer to [Section 1.7](#) for more information about the nameplate.

CAUTION!

Mechanical hazard – risk of damage to the hot runner. In the event of water leaking into the hot runner, the nozzle heaters could fail. Make sure all water is removed before starting up the hot runner.

5. Using compressed air, remove any water around the nozzle tips and parting lines.
6. Make sure all safety latches have been removed from the mold and hot runner.
7. Remove all locks and tags.

CAUTION!

Mechanical Hazard – Risk of damage to hot runner. Dry cycling the valve stems on a hot runner system is not recommended. Dry cycling can damage the valve stems, nozzle tips, and gate steel. If dry cycling is required for inspection of the hot runner, this should be kept to a minimum. If a long dry cycle of the injection molding machine is required, then it is not recommended to actuate valve stems during this operation.

5.2 Heating Up the Hot Runner, Mold and Machine

To bring the hot runner, mold and machine up to operating temperature, do the following:

1. If equipped, make sure the dryer is enabled and adjusted to the proper operating temperature.
2. Make sure the water chiller is enabled and adjusted to the proper operating temperature.
3. If equipped, make sure the mold enclosure de-humidifier, air compressor and water tower supplies are enabled.
4. Check the air pressure settings for the machine.
5. Make sure the compressed air for the mold is turned off. If the compressed air is left on as the hot runner heats up, air will leak from the system. This will cool the hot runner and delay the startup.
6. Slowly open the clamp to full shutheight.
7. Turn on the hot runner cooling system.



WARNING!

Hot resin spray hazard – risk of death or serious injury. Overheated resin can generate pressurized gas that when suddenly released can cause material to spray out. Do not allow resin to overheat. If the startup process is interrupted, turn off all barrel heaters and retract the injection unit to allow the hot runner to vent between the machine nozzle and the sprue bushing. For extended delays, follow the machine manufacturer’s and resin supplier’s procedures for machine shutdown.

8. Turn on the machine barrel heaters and allow them approximately 1/2 to 1 1/2 hours to reach operating temperature, depending on the size of the injection unit.

9. If equipped, turn on the controller.

CAUTION!

Mechanical hazard – risk of damage to the hot runner. Never operate the hot runner outside of the melt and mold temperatures indicated on the nameplate. Internal resin leakage or component damage could occur.

-
10. Set the temperature of the main manifold heaters, cross manifold heaters (if equipped) and sprue heater to the melt temperature indicated on the nameplate. Refer to [Section 1.7](#) for more information about the nameplate.



WARNING!

Hot resin spray hazard – risk of death or serious injury. The sprue heater must be turned on when the manifold heaters are turned on. Failure to do so could result in the generation of dangerous pressure levels in the manifold, resulting in the sudden release of hot resin.

-
11. Turn on the main manifold heaters, cross manifold heaters (if equipped) and sprue heater (if equipped) zones. Wait for the heaters to reach operating temperature. Wait an additional 10 minutes or more of soak time to make sure the resin has reached the operating temperature.
 12. Make sure the main manifold heaters and the cross manifold heaters (if equipped) reach the set temperature.
 13. Turn on the transfer bushing heaters (if equipped) zones. Wait for the heaters to reach the operating temperature and then wait an additional 10 minutes or more of soak time to make sure the resin has reached the operating temperature.
 14. Open the process material feed. Refer to the machine manufacturer's documentation for more information.

5.3 Precharging the Hot Runner

To precharge the hot runner with resin, do the following:

1. Close the clamp and apply tonnage.



WARNING!

Hot resin spray hazard – risk of death or serious injury. Molten resin under high pressure can suddenly release and spray out from the machine nozzle. Before purging the barrel or shooting pot, clear the area of all non-essential personnel and wear personal protective equipment consisting of a heat-resistant coat, heat-resistant gloves and a full face shield over safety glasses.

-
2. Purge the injection unit. Refer to the machine manufacturer's documentation for more information.

3. Clean the machine nozzle, stationary platen and purge guard of any resin deposits. Refer to the machine manufacturer's documentation for more information.
4. Make sure the machine nozzle is firmly seated against the sprue bushing.
5. Turn on the nozzle heaters and allow them approximately 5 to 7 minutes before mold operation to reach operating temperature.

CAUTION!

Mechanical hazard – risk of damage to equipment. Do not allow nozzle tips to stay energized for more than 10 minutes without injecting resin. Resin residing in the nozzle tip area will degrade.

-
6. While the nozzle heaters are reaching operating temperature, do the following:
 - a. Turn on the extruder screw to start plasticizing the resin.
 - b. Repeat [step 2](#) to [step 3](#).
 7. Move the machine nozzle forward until it is firmly seated against the sprue bushing.

NOTE:

The hot runner channels are properly filled with resin when the injection piston stops before making contact with the injection housing.

-
8. Inject resin into the hot runner until the injection piston stops. The piston must stop before it makes contact with the injection housing. If the piston makes contact with the injection housing, inject resin again.
 9. Once the injection piston stops, start the extruder screw and make sure it retracts fully.

5.4 Producing Test Parts

To produce test parts that will verify the settings and functions for the hot runner and machine, do the following:

1. Make sure the nozzle heaters have not timed out. If the nozzle heaters have timed out, do the following:
 - a. Enable the heaters and wait approximately 5 to 7 minutes to reach operating temperature.
 - b. Purge the injection unit. Refer to the machine manufacturer's documentation for more information.
 - c. Clean the machine nozzle, stationary platen and purge guard of any resin deposits. Refer to the machine manufacturer's documentation for more information.
2. Close the clamp and apply tonnage.
3. Make sure the machine nozzle is firmly seated against the sprue bushing.
4. Reduce the injection pressure to 70 bar (1000 psi) .
5. Disable all ejector functions to prevent the machine from automatically ejecting parts.
6. Cycle the machine once in normal mode to produce a set of parts.

- 7.** Check that all parts have been properly molded.
- 8.** Manually control the ejector functions to eject the parts.
- 9.** If all cavities are producing parts, reset the injection pressure to the recommended value.
- 10.** Cycle the machine four times in normal mode to produce parts. This will remove any air trapped in the resin.
- 11.** Visually inspect the last set of parts to verify the part quality. Repeat [step 10](#) until the part quality is satisfactory.
- 12.** Enable the ejector functions.
- 13.** If equipped, enable the product handling equipment.
- 14.** Cycle the machine 10 times in semi-cycle mode. During each cycle, if equipped, make sure the product handling equipment properly transfers the parts to the conveyor.
- 15.** Enable the auto-cycle mode for the machine and begin production.

Chapter 6 Maintenance

This chapter describes the maintenance tasks required to maintain the hot runner. Refer to [Section 6.1](#) for a full list of maintenance procedures.

NOTE:

Unless specified otherwise, all bolts, screws, fittings and other hardware should be torqued to the values listed on the assembly drawings specific to the hot runner.

**WARNING!**

Risk of injury. When entering the molding area, personal protective equipment must be worn to guard against burns, abrasions, hearing, foot, eye, and face hazards and any other procedure specific hazards listed in the manual.

**WARNING!**

Chemical hazard - Some of the chemicals used when servicing or maintaining Husky equipment are potentially hazardous and could cause injury and illness. Before storing, handling, or working with any chemical or hazardous material, thoroughly read and understand each applicable Material Safety Data Sheet (MSDS), use recommended personal protective equipment and follow the manufacturer's instructions.

**IMPORTANT!**

The procedures contained in this chapter were written for a standard hot runner and do not take special options into consideration.

6.1 Scheduled and Non-Scheduled Maintenance

Throughout the life of the mold and hot runner, various systems and components will need to be inspected and serviced on a scheduled or non-scheduled basis.

There are two types of maintenance procedures:

- Preventive procedures are performed at scheduled intervals
- Service procedures are performed when required

6.1.1 Preventive Maintenance

The following procedures must be performed when indicated as part of the recommended preventive maintenance program for the hot runner.

Interval	Cycles	Task Description	Reference
Every 6 Months	800,000	Test the hot runner heaters	Section 6.13
Every 18 Months	2,000,000	Change the hydraulic fluid	Machine manual
Every 36 months	Not applicable	Replace the manifold hoses	Section 6.11

6.1.2 Service Procedures

The following procedures are to be performed only when needed.

Procedure	Reference
Removing and Installing the nozzle stack	Section 6.2
Changing the resin color	Section 6.3
Extending nozzle and sprue heater (if equipped) wire leads	Section 6.4
Removing and Installing the hydraulic actuator	Section 6.5
Removing and Installing the pneumatic actuator	Section 6.6
Adjusting the valve stem preload for hydraulic actuators	Section 6.7
Replacing the hydraulic and pneumatic seals	Section 6.8
Removing and Installing valve stems	Section 6.9
Removing and Installing nozzle heaters	Section 6.10
Replacing the hydraulic or pneumatic manifold hoses	Section 6.11
Grounding the unify system	Section 6.12
Removing and Installing the cavity plate	Section 6.14
Inspecting and cleaning manifolds	Section 6.15
Removing insulating gate bubbles (if equipped)	Section 6.16
Removing and Installing the sprue heater	Section 6.17
Removing and Installing the sprue bushing	Section 6.18
Removing and Installing nozzle tip insulators	Section 6.19

6.2 Removing and Installing Nozzle Stacks

The nozzle stacks are pre-assembled and installed in the manifold system. To replace a nozzle stack component, use the following procedures to remove and install the nozzle stack. Part numbers and torque values are included in the assembly drawings.

6.2.1 Removing the Nozzle Stack

To remove the nozzle stack from a Unify manifold system, do the following:

1. Remove the Unify from the machine and position it so the nozzle stacks can be accessed. Refer to [Section 4.2.2](#).
2. Install the nozzle assembly tool over the housing assembly until the dowels of the tool engage with receiving holes in the manifold.
3. Remove the stepped washers and stepped washer fasteners.
4. Remove the nozzle assembly tool. Make sure to hold onto the nozzle stack housing assembly.
5. Remove the housing assembly from the manifold.

6.2.2 Installing the Nozzle Stack

To install the nozzle stack in the Unify manifold system, do the following:

1. Insert the locator and spring in the retainer, making sure the orientation is correct.

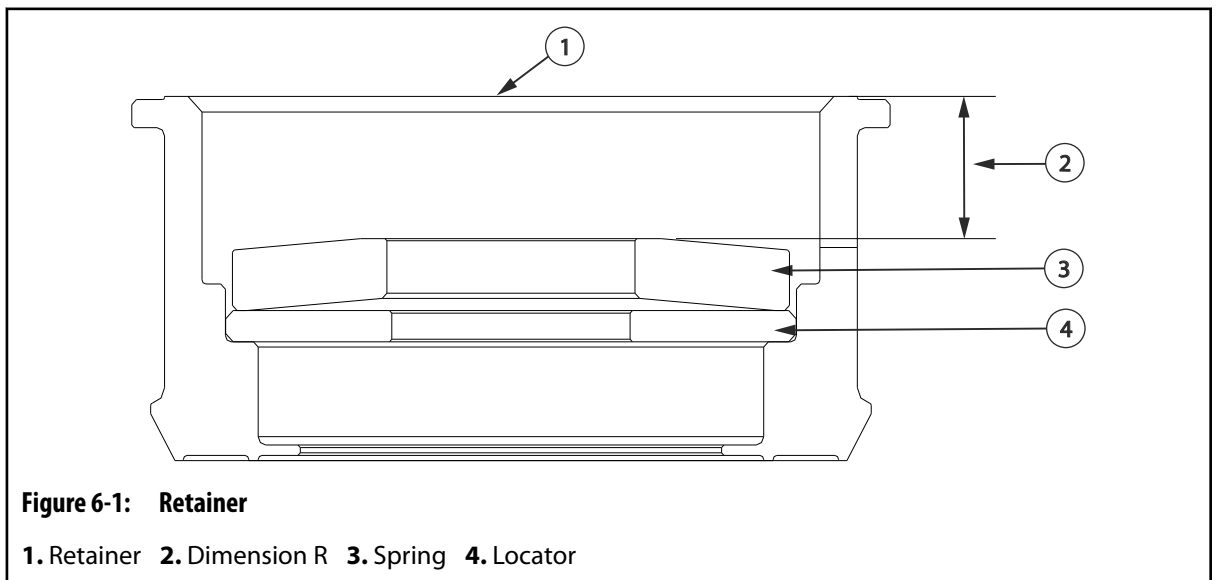

2. Measure the spring bore depth inside the retainer to verify it matches the dimension "R" on the assembly drawing.
3. Remove the locator and spring from the retainer.

4. Install the anti-rotation tab, spring and locator on the housing.

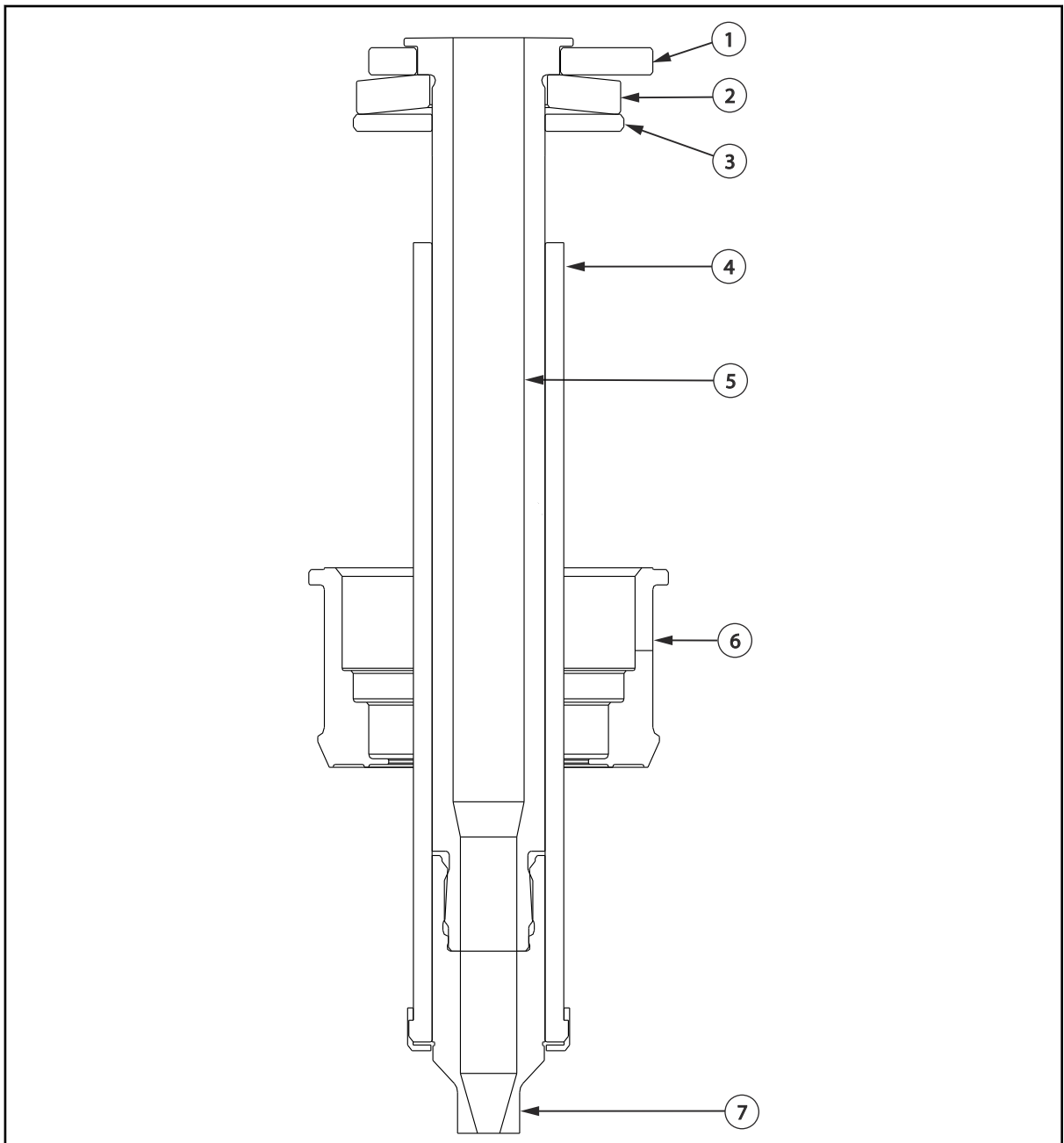
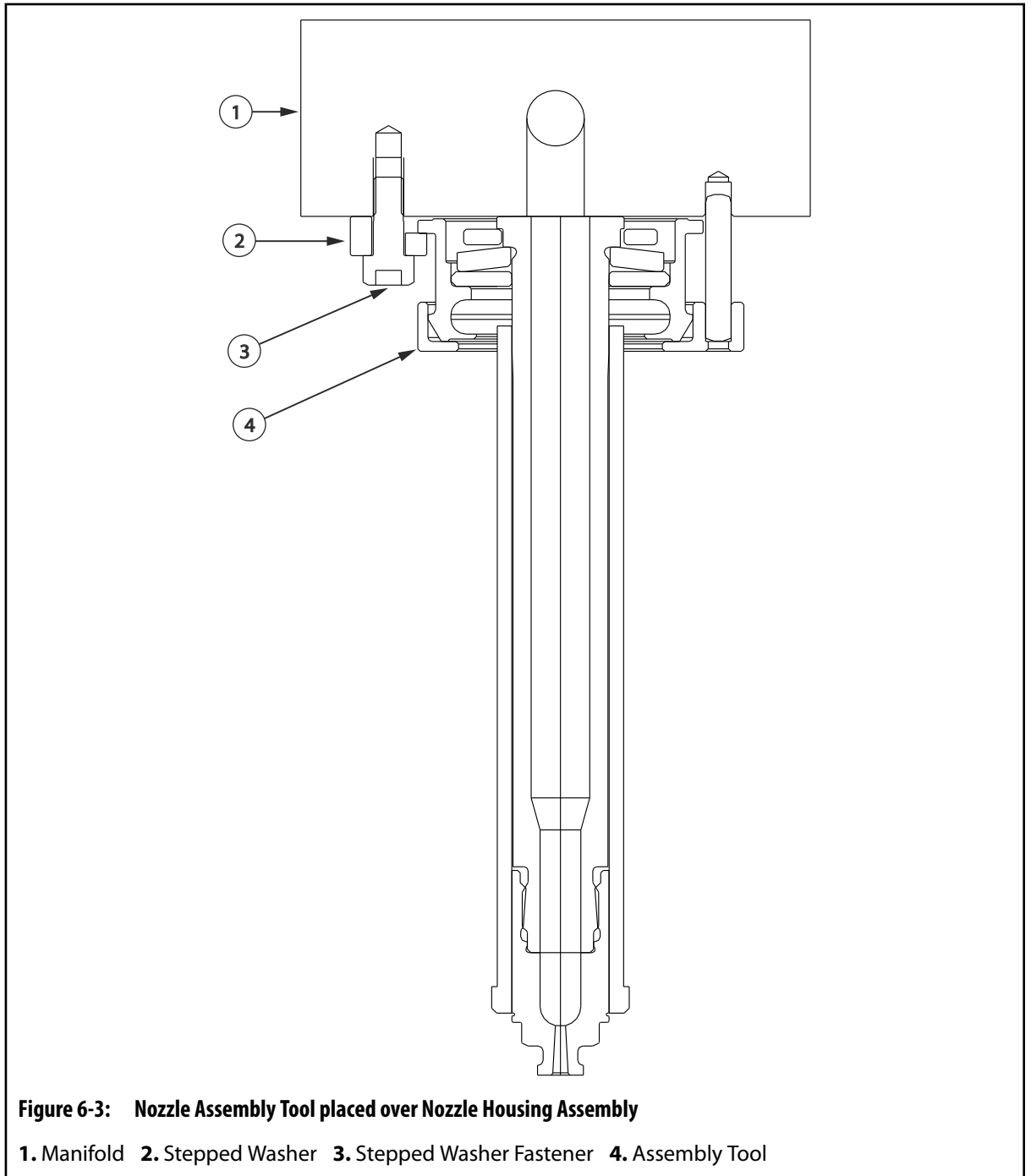

Figure 6-2: Anti-Rotation Tab, Spring and Locator on Nozzle Housing

1. Anti-Rotation Tab **2.** Spring **3.** Locator **4.** Nozzle Heater **5.** Nozzle Housing **6.** Retainer **7.** Nozzle Tip

- 5.** Install the nozzle tip and nozzle heater and thermocouple on the housing. Refer to [Figure 6-2](#).
- 6.** Install the retainer over the nozzle subassembly, guiding the nozzle heater and thermocouple wires through the retainer wire exit channel.
- 7.** Hold the housing subassembly from [step 6](#) and place it against the manifold drop, aligning the anti-rotation dowel with one of the corresponding slots on the retainer.

8. Install the nozzle assembly tool over the housing assembly until the dowels of the tool engage with receiving holes in the manifold.
9. With the assembly tool in place, install the stepped washers and stepped washer fasteners. Apply the fastener preload according to the assembly drawing.



10. Remove the nozzle assembly tool.
11. Measure the preloaded retainer height from the manifold (Dimension S) to verify it matches the assembly drawing. Refer to [Figure 6-4](#).

- 12. Measure the nozzle tip height from the manifold (Dimension T) to verify it matches the assembly drawing. Refer to [Figure 6-4](#).

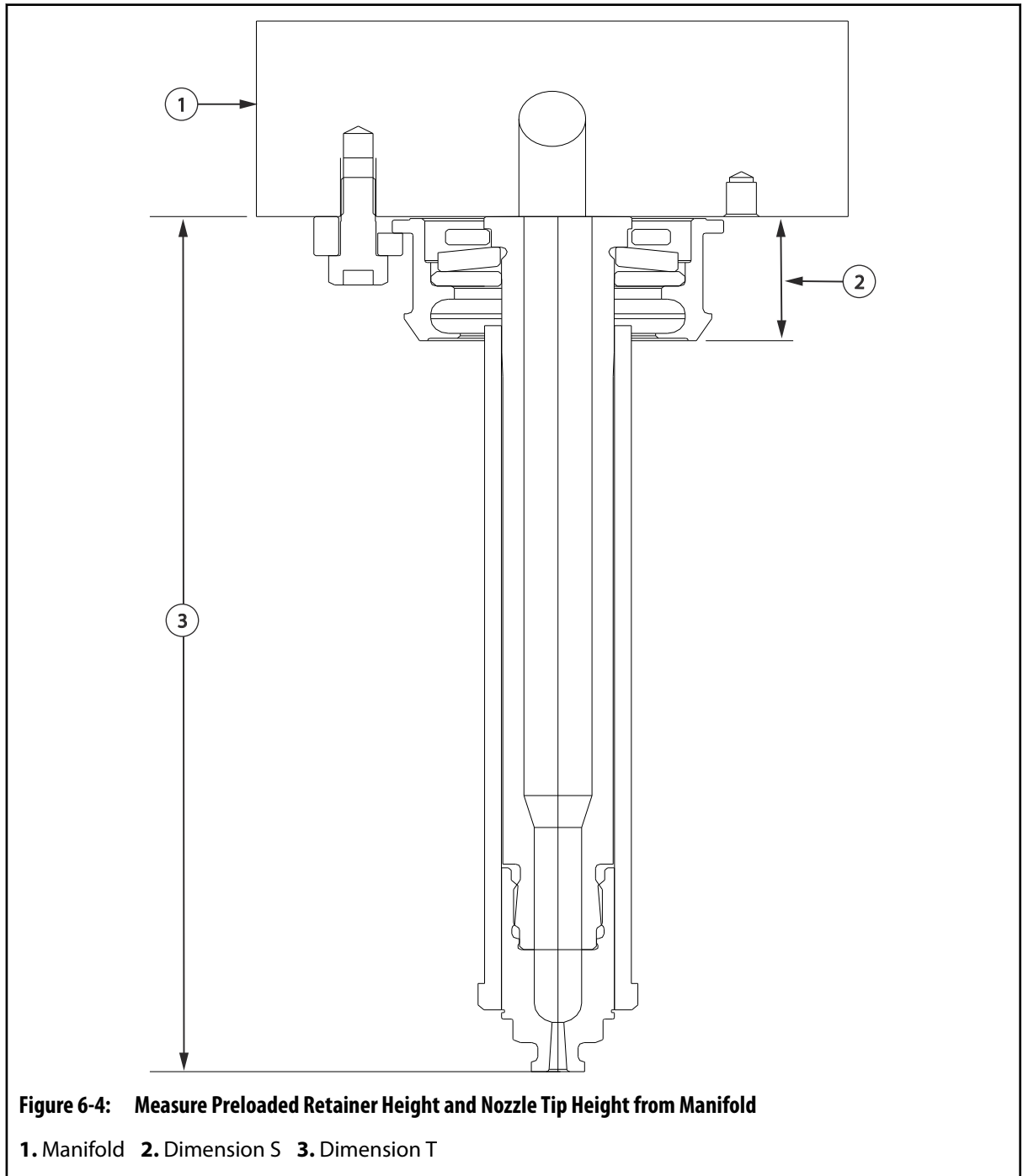

6.3 Changing the Resin Color

To change the color of the resin, do the following:

1. Lock out and tag the machine and controller (if equipped). For machine lockout and tag procedures refer to the machine documentation.
2. Remove all traces of the original resin from the material feed equipment.
3. Depending on application restrictions, add one of the following to the material feed equipment to reduce the cleaning time required:
 - Purge compound
 - Natural (uncolored) resin
 - New colored resin
4. Remove all locks and tags.
5. Power up the machine and turn on the controller (if equipped).



WARNING!

Hot resin spray hazard – risk of serious injury. Molten resin under high pressure can suddenly release and spray out from the machine nozzle. Before purging the injection unit, clear the area of all non-essential personnel and wear personal protective equipment consisting of a heat-resistant coat, heat-resistant gloves and a full face shield over safety glasses.

6. Purge the injection unit until all traces of the old color are eliminated. For instructions, refer to the machine manufacturer's documentation.
7. Increase the injection speed to the maximum value allowed by the application.
8. Reduce the hold time and cooling time to the minimum values allowed by the application.
9. Increase the temperature of the hot runner nozzle tips, manifold and sprue by 20 to 30 °C (68 to 86 °F) .
10. Repeat [step 3](#) to replenish the material feed system, if required.
11. Produce a series of test parts until all traces of the old color are eliminated.
12. When the color change is complete, decrease the temperature of the nozzle tips, manifold and sprue by 20 to 30 °C (68 to 86 °F) .
13. Return the hold time, cooling time and injection speed back to their original values.
14. Fill the material feed equipment with the new resin.

6.4 Extending Nozzle and Sprue Heater Wire Leads

The following procedure describes how to install the nozzle and sprue heater lead splice kit (P/N 4047310) to extend the length of the nozzle and sprue heater wires. This kit may be required on systems where the wire leads are not long enough to reach the electrical connectors.



IMPORTANT!

This procedure is only for nozzle and sprue heater leads when standard lead lengths are not long enough.

This procedure is not to be used for extending thermocouple wire leads. Splicing thermocouple wires will cause false and/or erratic temperature readings.

When required, standard thermocouples are available with longer wire lead lengths.

To install the kit, do the following:

1. Strip the ends of the wire and the wire supplied with the kit until 6 mm (0.2 in) of wire lead is exposed on both.
2. Slide heat shrink tubing over the butt connector. Make sure the butt connector is centered in the tubing.

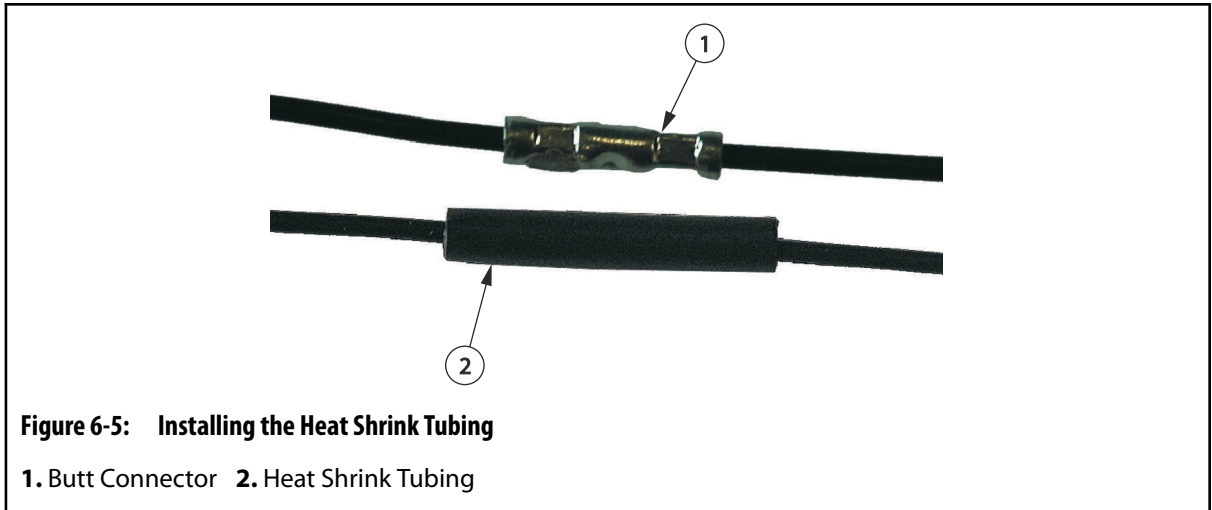

3. Insert the wires into both ends of the butt connector until no wire lead is visible.

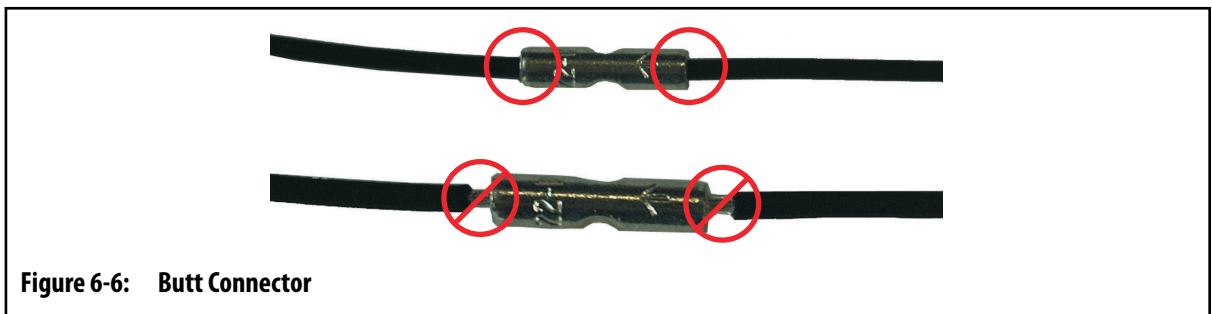

4. Using a crimping tool, crimp one end of the butt connector at a time.
5. Shrink the tubing using a heat gun.
6. Seal the ends of the heat shrink tubing where the tubing meets the wire lead insulation.

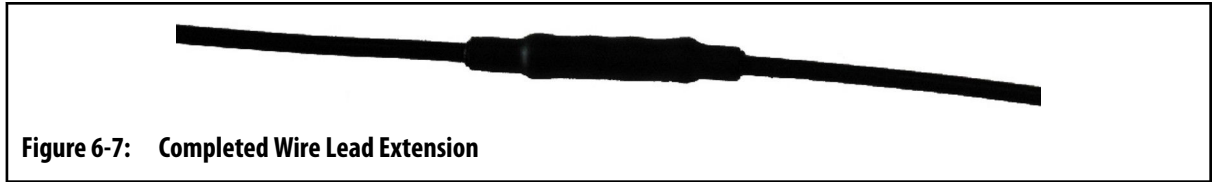

6.5 Removing and Installing the Hydraulic Actuator

This section describes how to remove and install the hydraulic actuator.

6.5.1 Removing the Hydraulic Actuator from the Manifold

To remove the hydraulic actuator from the manifold, do the following:



WARNING!

Skin puncture hazard – risk of serious injury. High pressure fluid injected into skin could result in death or amputation. Use a pressure gauge to verify all pressure has been removed before servicing a hydraulic circuit.

1. Make sure the oil pressure is depleted from all lines before removal.
 2. Remove the hydraulic and water hoses from the actuator.
-

NOTE:

Oil and water may drool from the actuator and hoses.

3. Pull the spring pin to disengage it from the valve stem.

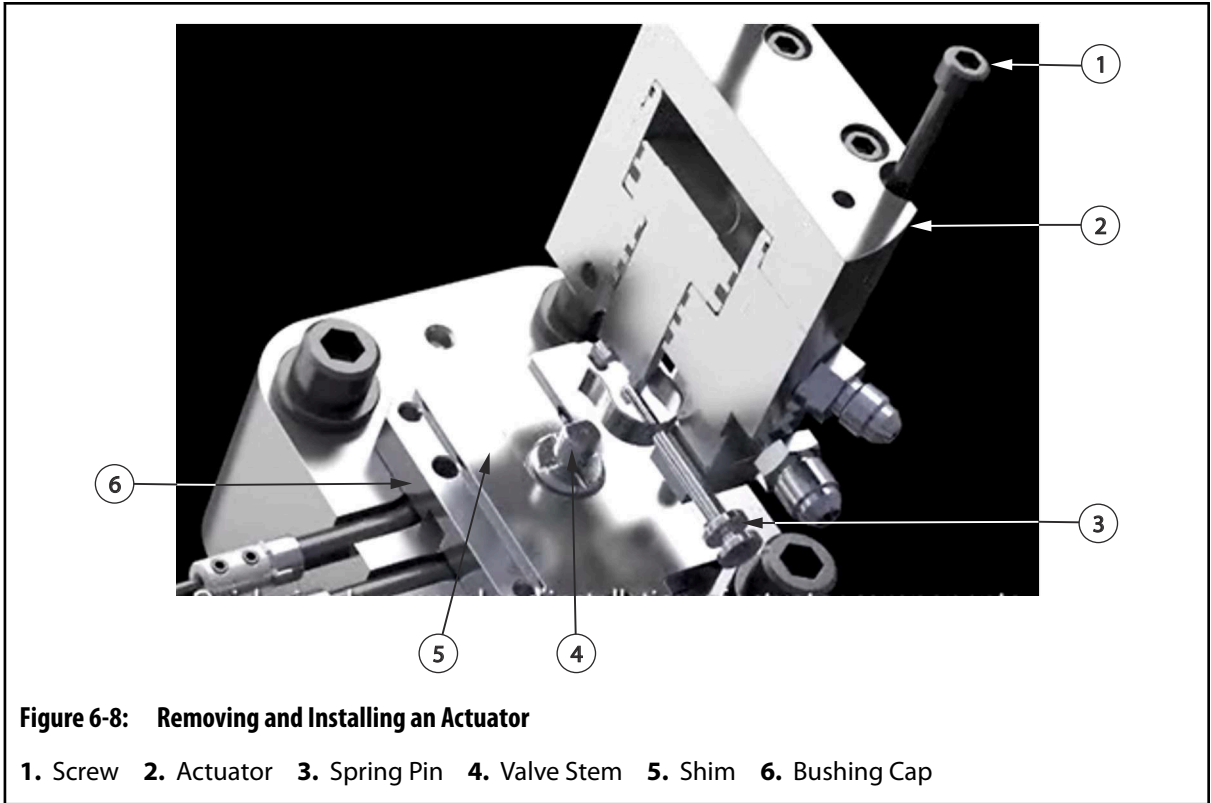

- 4. Loosen the screws on outer perimeter of actuator.
- 5. Remove the shim and label the shim with the drop location.
- 6. Remove the screws on the outer perimeter of actuator.
- 7. Lift the actuator vertically from the manifold.
- 8. Label the actuator with the drop location.

6.5.2 Installing the Hydraulic Actuator on the Manifold

To install the hydraulic actuator to the manifold, do the following:

- 1. Make sure that the piston in the actuator is in the closed position.
- 2. Install the shim on the bushing cap. The shim was labeled by drop location when the actuator was removed (Refer to [Section 6.5.1](#)). Make sure the correct shim is installed for the drop location.

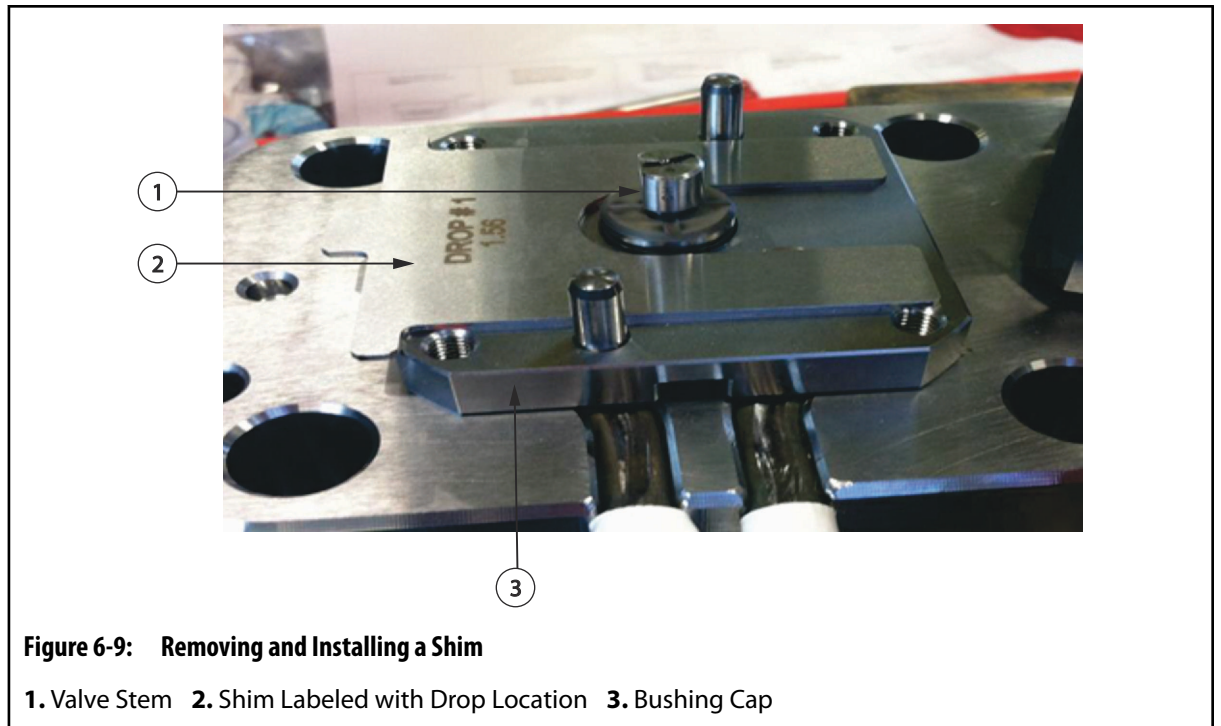

3. Lower the hydraulic actuator vertically onto the drop location. The actuator is labeled by drop location (Refer to [Section 6.5.1](#)). Make sure the correct actuator is installed for the drop location.
4. Install, but do not tighten, the screws on the outer perimeter of the actuator.

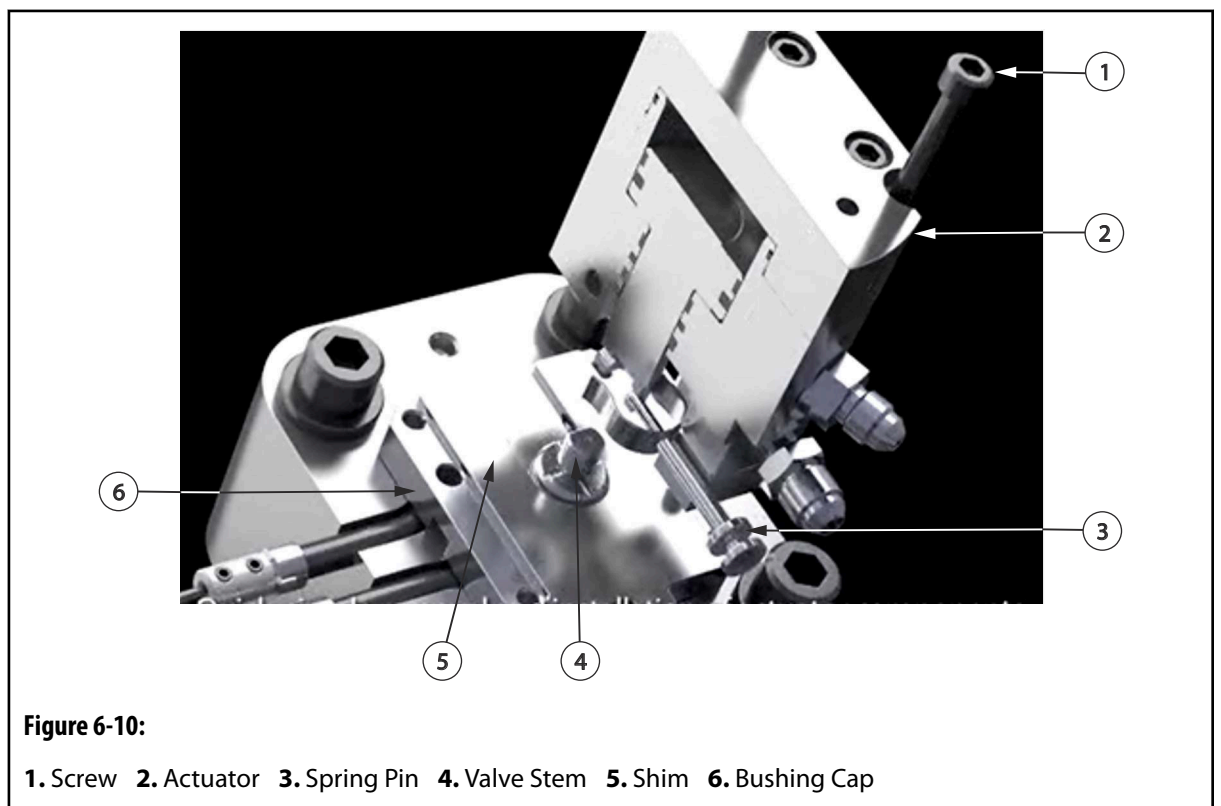

5. Tighten the screws installed in [step 4](#). Refer to the assembly drawings for torque specifications.
6. Push the spring pin to engage it with the valve stem.
7. Connect the hydraulic and water hoses to the actuator.

6.6 Removing and Installing the Pneumatic Actuator

This section describes how to remove and install the pneumatic actuator on the manifold.

6.6.1 Removing the Pneumatic Actuator from the Manifold

To remove the pneumatic actuator from the manifold, do the following:

1. Remove all air pressure from the air lines.
2. Disconnect the air hoses from the actuator.
3. If equipped with a thermal regulator, remove water hoses from the thermal regulator.

NOTE:

Water may drool from the actuator and hoses.

4. Loosen the screws on the outer perimeter of actuator.

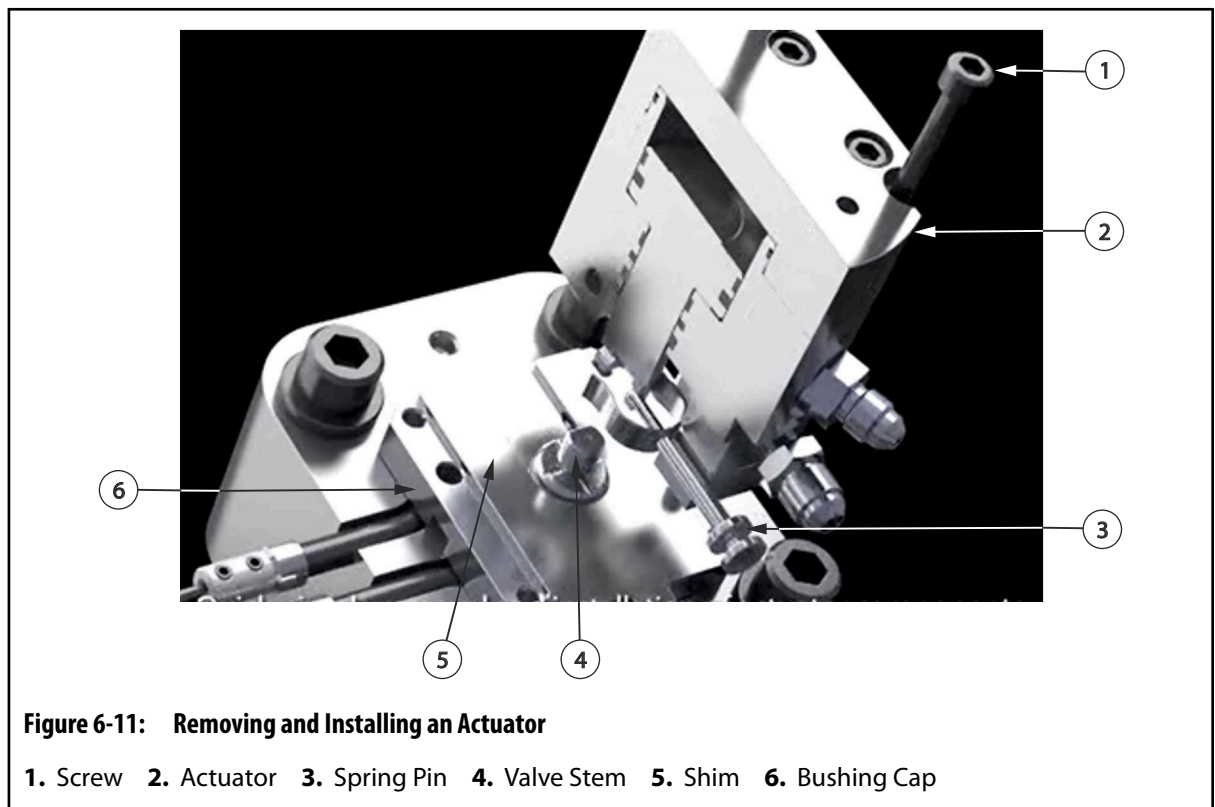

5. Pull the spring pin to disengage it from the valve stem.

6. Remove the screws on the outer perimeter of the actuator.
7. Remove the actuator vertically from the manifold.
8. Label the actuator with the drop location.

6.6.2 Installing the Pneumatic Actuator to the Manifold

To install the pneumatic actuator to the manifold, do the following:

1. Make sure that the piston in the actuator is in the closed position.
2. If equipped with a thermal regulator, install the disc spring at the drop location that will contain the thermal regulator.
3. If equipped, install the thermal regulator onto the disc spring.
4. Install the actuator at the drop location or over the thermal regulator, if equipped. The actuator is labeled by drop location (Refer to [Section 6.6.1](#)). Make sure the correct actuator is installed for the drop location.

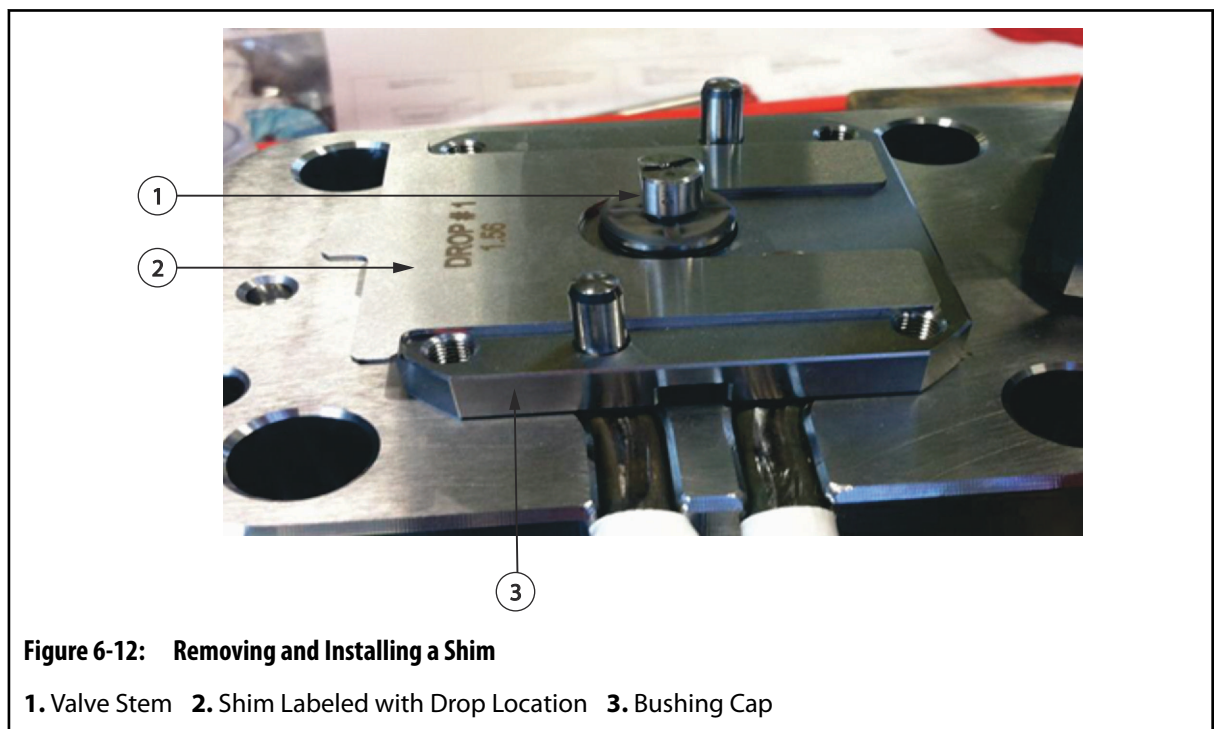

5. Install, but do not tighten, the screws on the outer perimeter of the actuator.

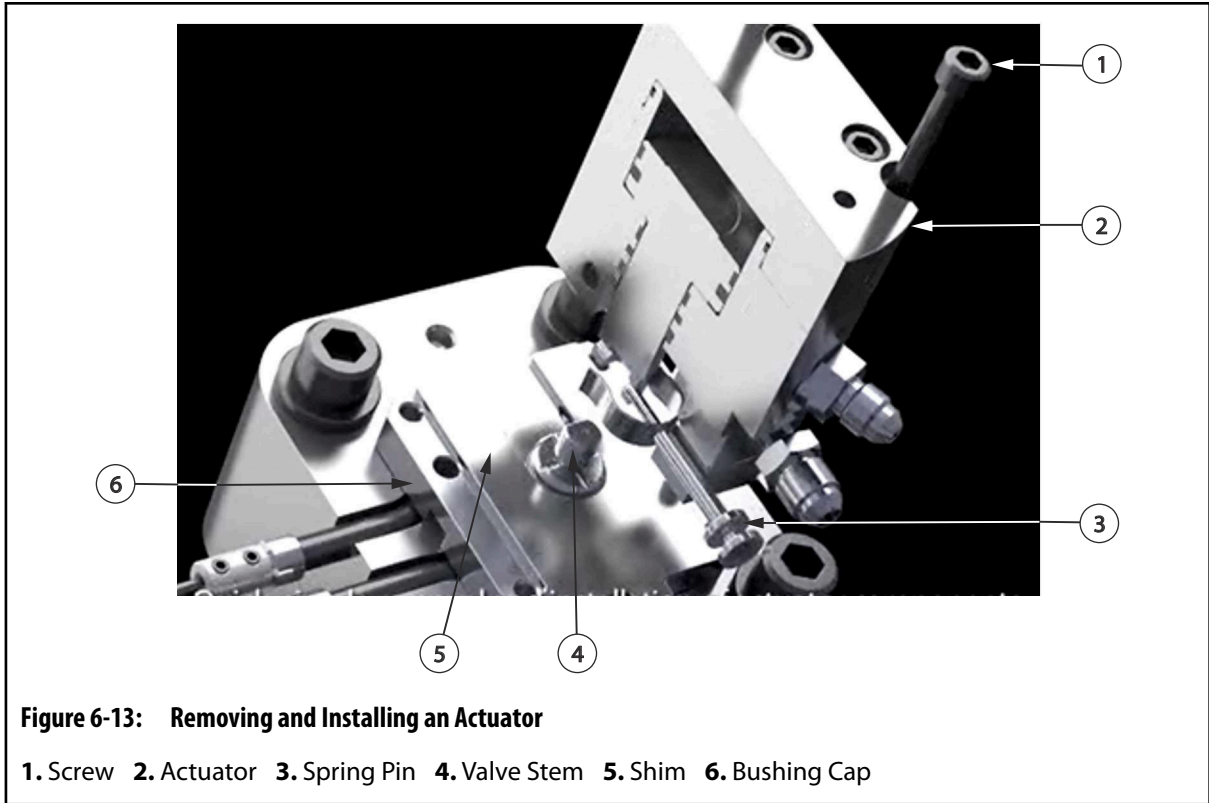

Figure 6-13: Removing and Installing an Actuator

1. Screw 2. Actuator 3. Spring Pin 4. Valve Stem 5. Shim 6. Bushing Cap

- 6. Push the spring pin to engage it with the valve stem.
- 7. Tighten the screws installed in [step 5](#). Refer to the assembly drawings for torque specifications.
- 8. If equipped with a thermal regulator, connect the water hoses to the thermal regulator.
- 9. Connect the air hoses to the actuator.

6.7 Adjusting the Valve Stem Preload for Hydraulic Actuators

For VX style nozzle tips and tapered stem shut-off, where the stems shut-off on the nozzle tips, Husky delivers the stem preload as identified on the assembly drawing.

For VG style nozzle tips, where tapered stems shut-off on a gate or cavity insert, Husky delivers the stem preload as identified on the assembly drawing. This assumes that the gate insert L dimension is within specification.

A shim is included in every hydraulic actuator assembly to control tapered valve stem preload.

To verify or change the valve stem preload for a hydraulic actuator, do the following:

- 1. Remove the hydraulic actuator and shim (refer to [Section 6.5](#)) from the nozzle drop to expose the valve stem head. Make sure that the stem is in the fully forward (stem closed) position.
- 2. Measure and record the stem seat depth of the piston in the cylinder assembly (Dimension V) as shown in [Figure 6-14](#).

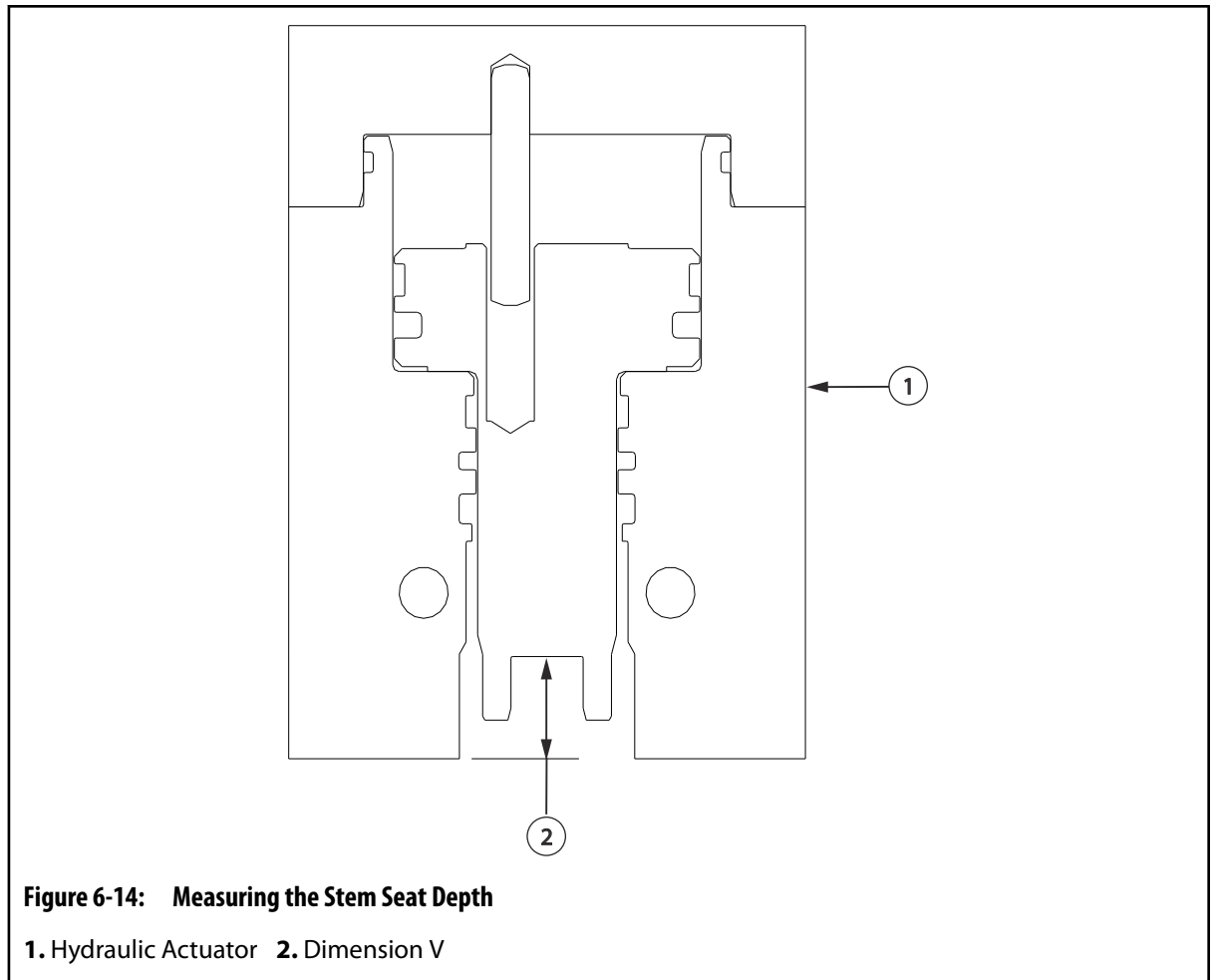

3. Measure and record the height of the stem from the bushing cap (Dimension W) as shown in [Figure 6-15](#).

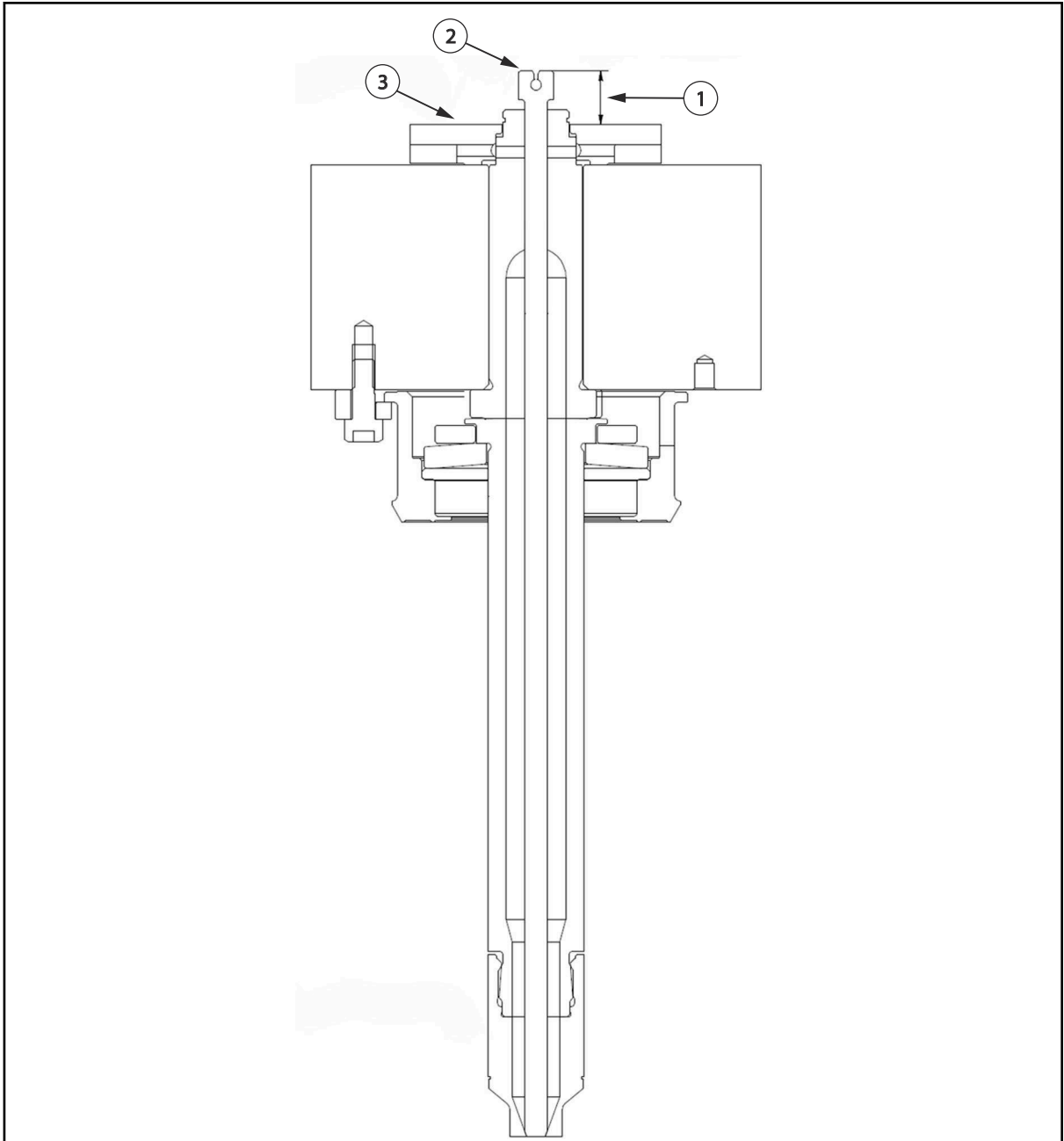
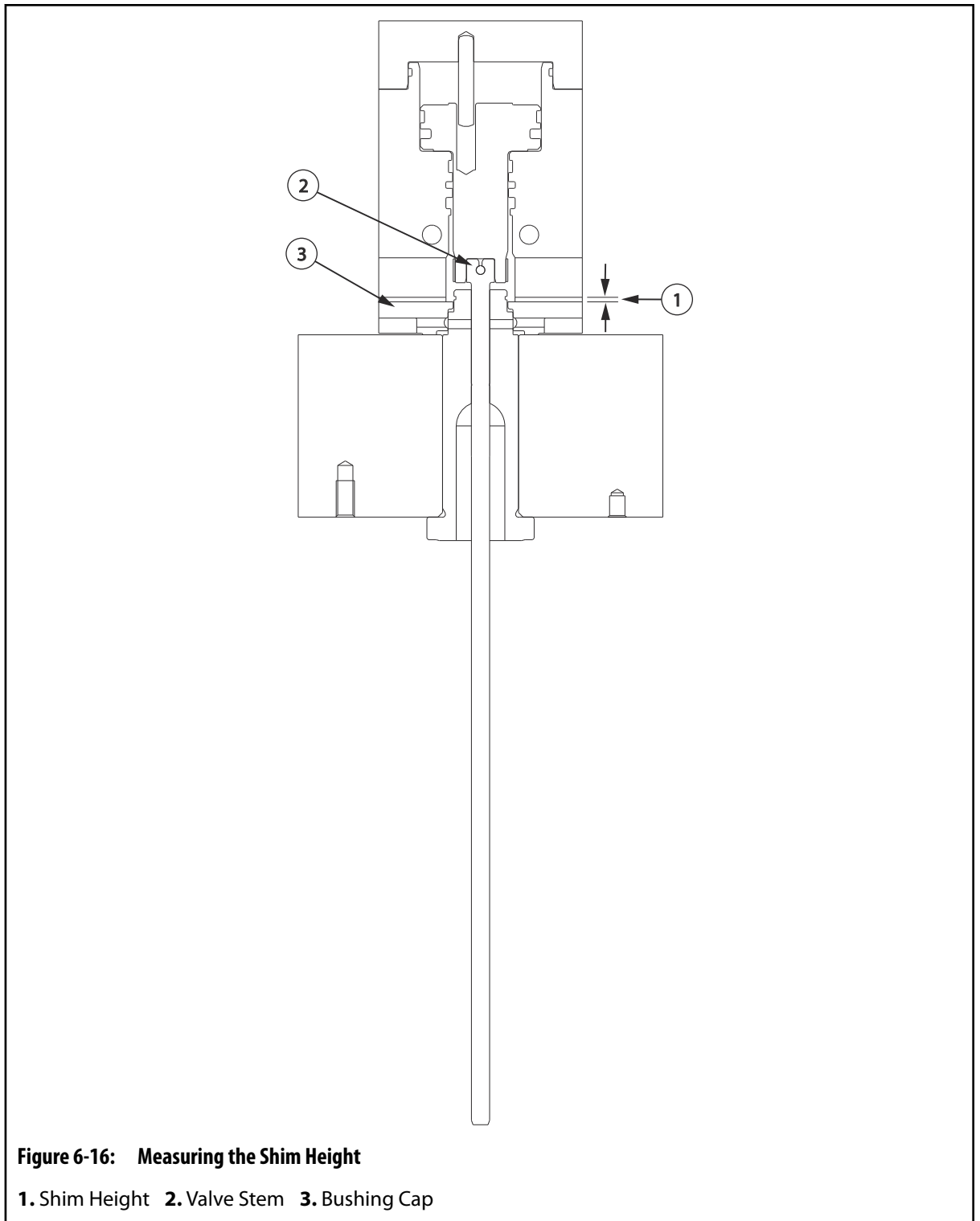

Figure 6-15: Measuring the Stem Height

1. Dimension W 2. Valve Stem 3. Bushing Cap

4. The shim thickness is engraved on the shim. Refer to [Figure 6-15](#). Record this value. If the shim thickness has been modified, measure and record the new shim thickness. Refer to [Figure 6-16](#).
5. Calculate the current valve stem preload with the following equation:

$$\text{Valve Stem Preload} = \text{Dimension W} - \text{Dimension V} - \text{Shim Thickness}$$
6. To achieve the desired preload, modify the shim thickness.



6.8 Replacing the Hydraulic and Pneumatic Seals

The life of hydraulic or pneumatic actuator seals will decrease if the system operates outside of the operating limits.

The following options are available if hydraulic or pneumatic actuator seals need to be replaced. Contact Husky for more information.

- Order new pre-assembled actuators, which have been fully tested, from Husky.
- Husky can refurbish the actuator.
- Husky can replace the seals or a seal kit that includes new seals can be ordered from Husky.

NOTE:

It is recommended that Husky performs the actuator seal replacement.

Instructions on disassembling the actuator and installing the new seals are included in the seal kit.

Actuator Type	Part Description	Part Number
Small Hydraulic	Seal Kit	7296393
Large Hydraulic	Seal Kit	6735248
Small and Large Hydraulic	Tool Kit - Not included in the seal kit	6618499
Small Pneumatic	Seal Kit	6990407
Large Pneumatic	Seal Kit	6990408
Small and Large Pneumatic	Outer Piston Seal	6718718
	O-ring Piston	212808
	Outer Rod Seal	671824
	O-ring Rod	642805

6.9 Removing and Installing Valve Stems

The following procedures describe how to remove and install the valve stems.

6.9.1 Removing a Valve Stem

To remove a valve stem, do the following:

1. Remove the actuator. Refer to [Section 6.5](#) for the hydraulic actuator or [Section 6.6](#) for the pneumatic actuator.
2. Clean the manifold bushing cap to provide a clean surface.
3. Use the Unify Stem Removal tool (HPN 6700292) to slide the stem adapter over the valve stem head. Make sure that the removal tool assembly is sitting squarely on the manifold bushing cap.

NOTE:

Husky recommends that the stack be heated with the nozzle heater and or manifold to soften the resin.

CAUTION!

Mechanical hazard - risk of damage to the valve stem. Do not use a slide hammer when removing the valve stem.

4. Remove the valve stem.

6.9.2 Installing a Valve Stem

To install a valve stem, do the following:

1. Make sure all components are clean and free of resin, scratches, nicks or burrs. Replace components if required.

NOTE:

Husky recommends that the stack be heated with the nozzle heater and or manifold to soften the resin.

2. Carefully insert the valve stem assemblies into the manifold bushing cap. Make sure the pistons are seated below the top surface of the cylinders.

6.10 Removing and Installing Nozzle Heaters

The following procedures describe how to remove and install nozzle heaters. The following types of nozzle heaters are supported:

**IMPORTANT!**

Husky nozzle heaters are rugged and have a long service life. Only replace nozzle heaters with Husky approved parts. Use of components not sold or approved by Husky will void the hot runner warranty.

- Ultra Nozzle Heaters (UNH) for U750 systems

- Bi-metal heaters for U750 and U1000 systems
- Triton heaters for U750-UP systems
- HTM heaters for U1000 systems

6.10.1 Removing and Installing Ultra Nozzle Heaters (UNH) on U750 Systems

The following procedures describe how to remove and install Ultra Nozzle Heaters (UNH) nozzle on U750 systems.

6.10.1.1 Removing Ultra Nozzle Heaters (UNH) on U750 Systems

To remove an Ultra Nozzle Heater (UNH) on U750 Systems, do the following:

1. Separate or remove the cavity plate from the manifold.
2. Remove the nozzle retainer.

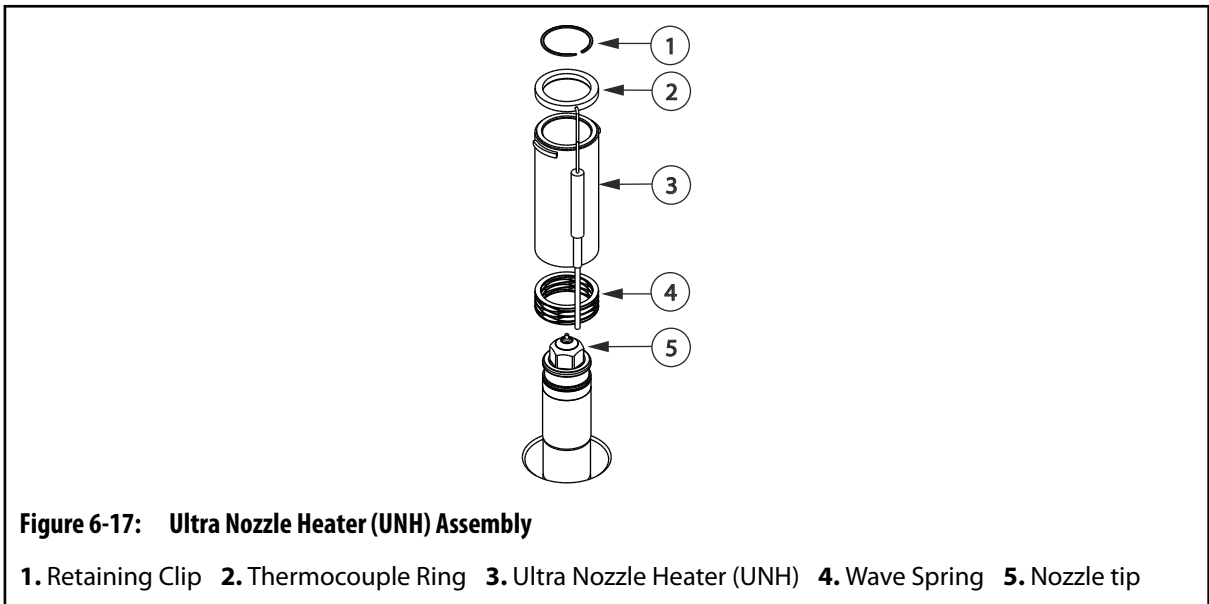

3. While holding the retaining clip and nozzle heater firmly against the wave springs, remove the retaining clip from the nozzle tip.
4. Remove the thermocouple ring.
5. Remove the nozzle heater.
6. Remove and discard the wave springs.

6.10.1.2 Installing Ultra Nozzle Heaters (UNH) on U750 Systems

To install an Ultra Nozzle Heater (UNH) on U750 Systems, do the following:

1. If required, separate or remove the cavity plate from the manifold.
2. Remove the nozzle retainer.
3. Install new wave springs over the nozzle housing and nozzle tips.

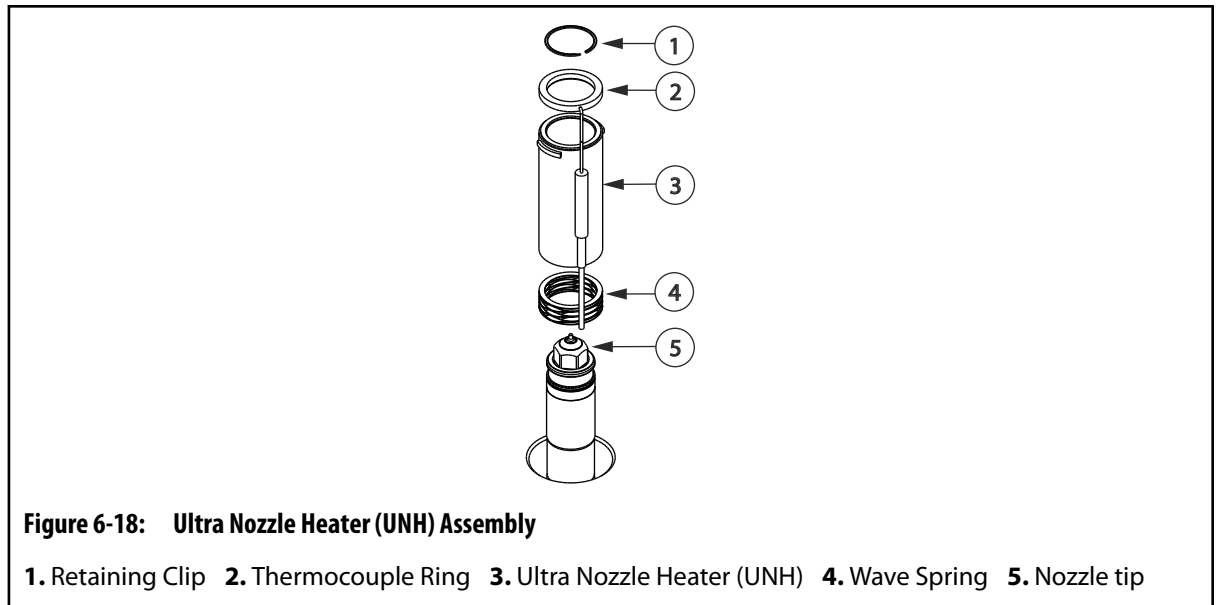

4. Slide the nozzle heater over the nozzle housing far enough to show the retaining clip groove on the nozzle tip.
5. Slide the thermocouple ring over the nozzle tip, onto the nozzle heater, far enough to show the retaining clip groove on the nozzle tip.
6. Install the retaining clip on the nozzle tip and pull the nozzle heater and thermocouple ring up against it.

CAUTION!

Mechanical hazard – risk of damage to the hot runner. Do not bend the nozzle heater wires at a 90° angle. Do not bend the nozzle heater wires directly at the lead exit of the heater body. The wires will crack or break over time.

7. On U750 heaters, bend the nozzle heater wires in an arc against the heater body. Make sure each bend has a minimum 10 mm (0.4 in) radius.

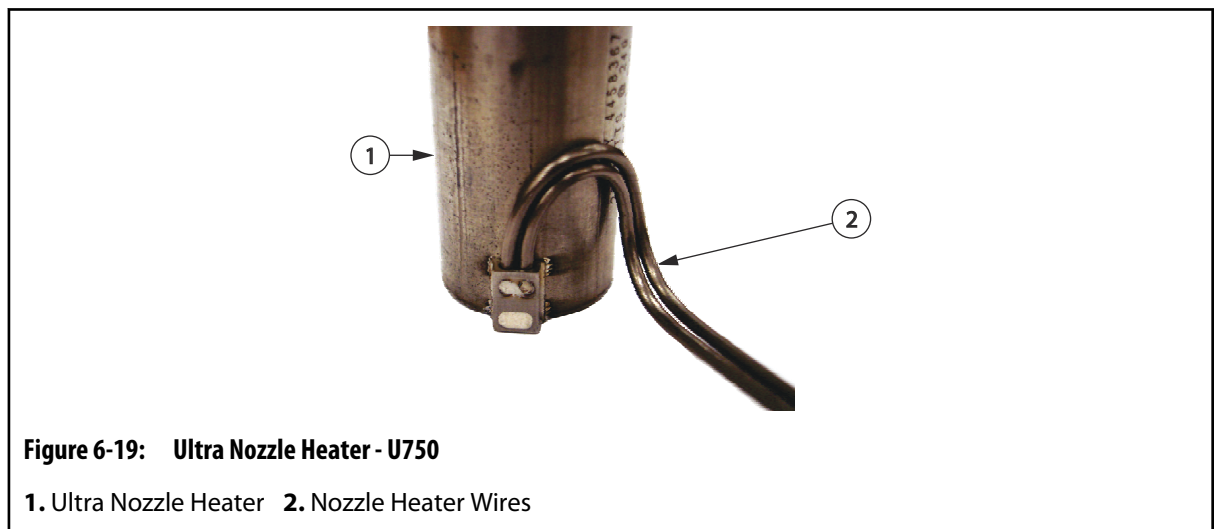

- 8. Install the nozzle retainer but do not tighten it.
- 9. Route the nozzle heater and thermocouple wires through the wire passages on the nozzle retainer. Refer to [Figure 6-20](#).

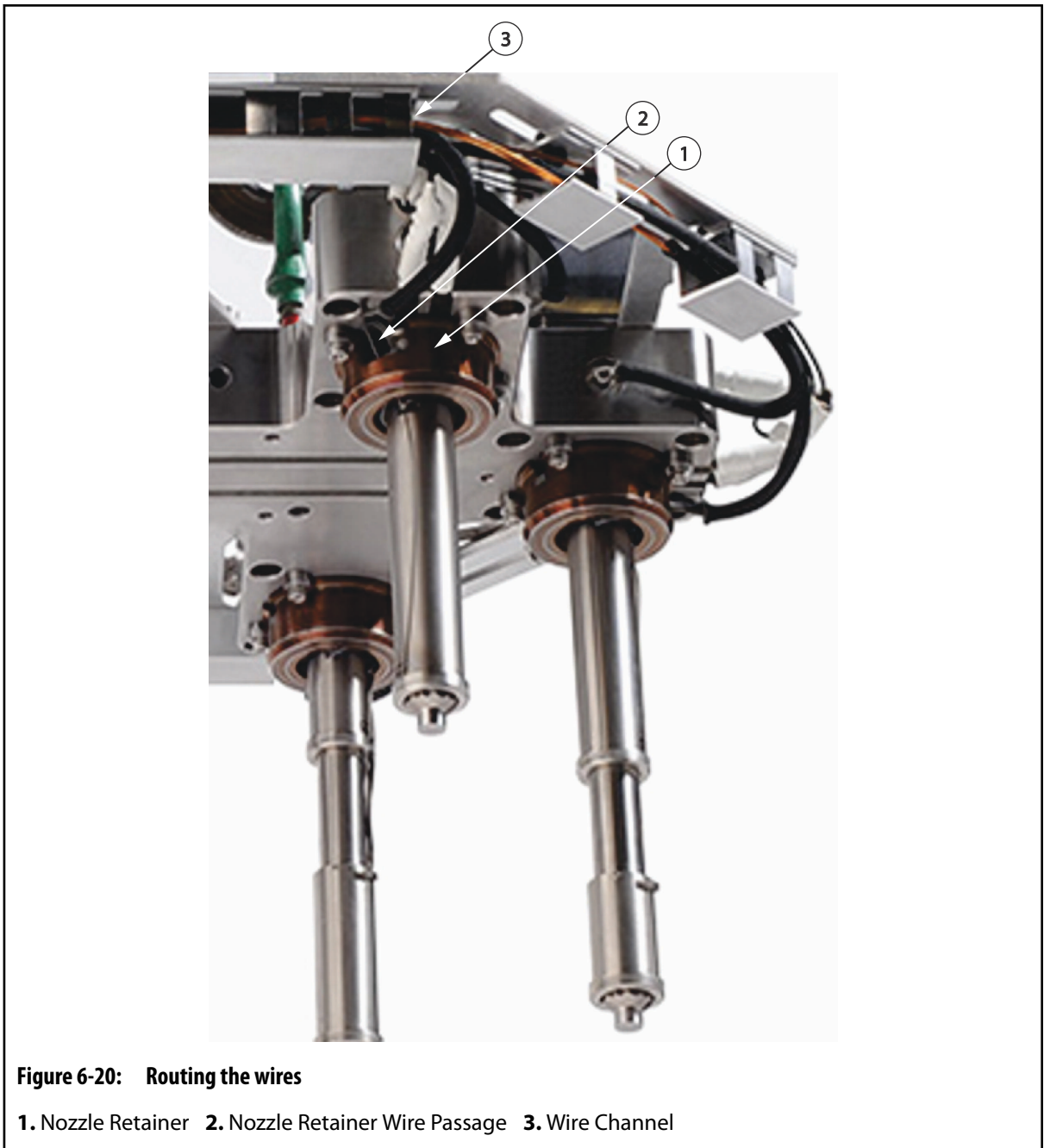

- 10. Tighten the nozzle retainer.
- 11. Route the wires into the wire channel on the manifold frame. Make sure all wiring is properly retained in the wire channel using wire clips.
- 12. Make sure to stagger the knuckles in the wire channel.



Figure 6-21: Staggering the Knuckles in the Wire Grooves

NOTE:

All wire, including heater or thermocouple wire, that could contact a heated component such as a nozzle housing or manifold must be mineral insulated high temperature wire (hard lead). If the mineral insulated lead is not long enough to allow this, additional steps must be taken, such as using high temperature sleeving, to prevent the knuckles and PTFE or Kapton insulated wire (soft lead) from overheating.

13. Label each wire with the heater zone number. Refer to the electrical schematic for the zone number.
14. Crimp the wire ends and connect the wires to the appropriate multi-pin connectors. Refer to the electrical schematic for more information.
15. Test each nozzle heater. Refer to [Section 6.13](#) for more information.

6.10.2 Removing and Installing Ultra Nozzle Heaters (UNH) With Ring Thermocouples

The following procedures describe how to remove and install ultra nozzle heaters with ring thermocouples (UNH 500 and UNH 750).

6.10.2.1 Removing Ultra Nozzle Heaters (UNH) With Ring Thermocouples

To replace an Ultra Nozzle Heater (UNH) with a ring thermocouple, do the following:

1. Separate or remove the cavity plate from the hot runner. Refer to [Section 6.14](#) for more information.
2. Remove the retaining clip from the nozzle tip.
3. Remove the necessary wire clips to expose the nozzle heater and thermocouple wires.
4. Remove the ring thermocouple.

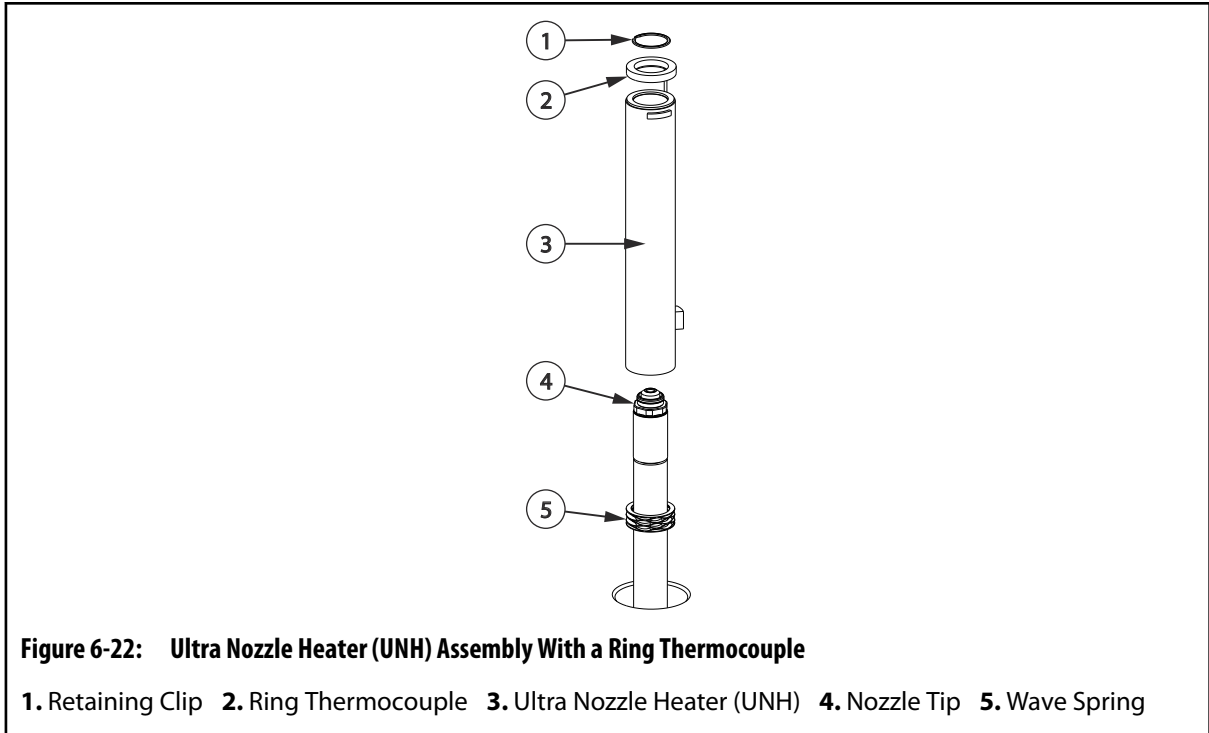

- 5. Remove the nozzle heater.
- 6. Remove and discard the wave springs.

6.10.2.2 Installing Ultra Nozzle Heaters (UNH) With Ring Thermocouples

To install an Ultra Nozzle Heater (UNH) with a ring thermocouple, do the following:

- 1. Install new wave springs over the nozzle housing and nozzle tip.

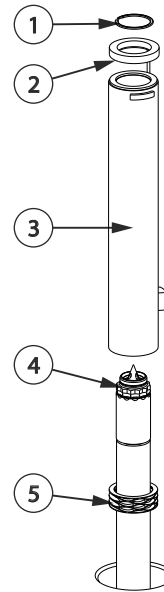

Figure 6-23: Ultra Nozzle Heater (UNH) Assembly With a Ring Thermocouple

1. Retaining Clip 2. Ring Thermocouple 3. Ultra Nozzle Heater (UNH) 4. Nozzle Tip
5. Wave Spring

2. Slide the nozzle heater over the nozzle housing far enough to show the retaining clip groove on the nozzle tip.
3. Slide the ring thermocouple over the nozzle tip, on to the nozzle heater, far enough to show the retaining clip groove on the nozzle tip.
4. Install the retaining clip on the nozzle tip and pull the nozzle heater and ring thermocouple up against it.



IMPORTANT!

Make sure the retaining ring is snapped fully into the retaining clip groove around the whole diameter of the nozzle tip. Refer to the following figure.

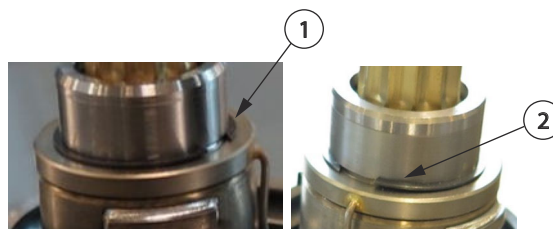

Figure 6-24: Retaining Ring in Nozzle Tip Groove

1. Retaining Clip Fully Seated in Groove (Correct)
2. Retaining Clip Not Fully Seated in Groove (Incorrect)

CAUTION!

Mechanical hazard – risk of damage to the hot runner. Do not bend the nozzle heater wires at a 90° angle. Do not bend the nozzle heater wires directly at the lead exit of the heater body. The wires will crack or break over time.

5. On U750 heaters, bend the nozzle heater wires in an arc against the heater body. Make sure each bend has a minimum 10 mm (0.4 in) radius.

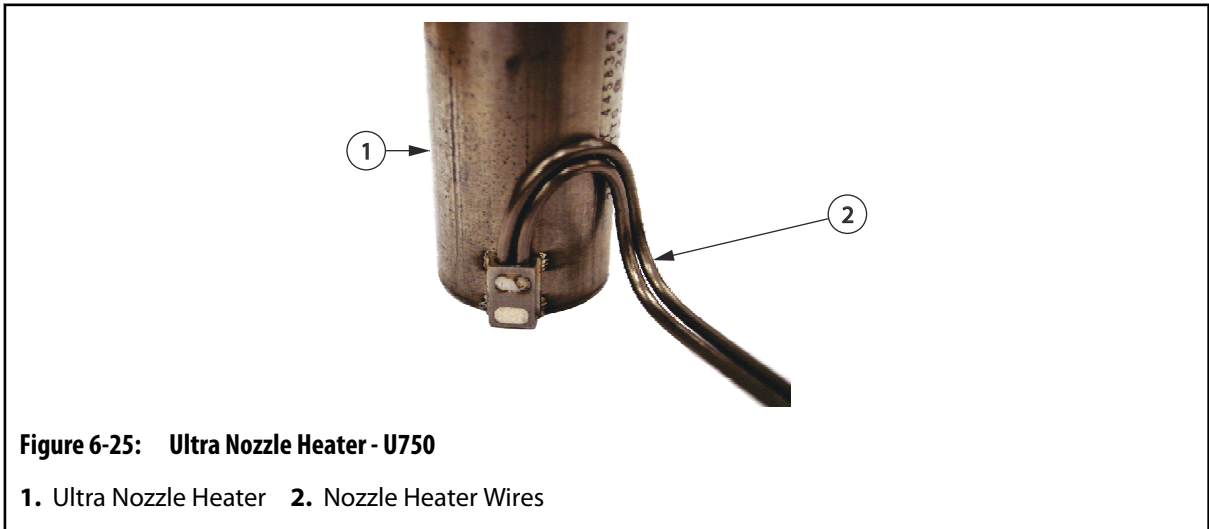

6. On U500 heaters, first bend the leads along the curvature of the heater, and then bend them up or down (away from the lead exit of the heater body) to meet the manifold plate wire groove as required.

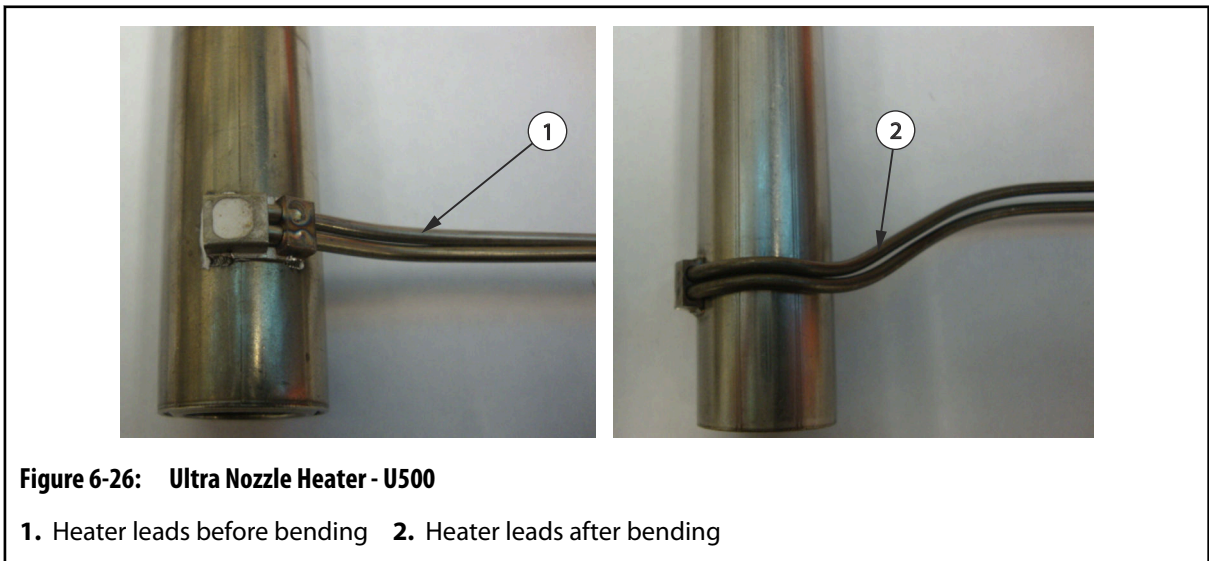

7. Route the nozzle heater and thermocouple wires through the wire channels in the manifold plate. Make sure all wiring is properly retained in the wire channels using wire clips. Make sure of the following:
 - a. Wiring does not protrude above the plate surface.

- b.** The heater and thermocouple spring back to the retaining ring and maintain contact with each other after being pushed down (0.5 to 2mm) on the housing. See the following figure.

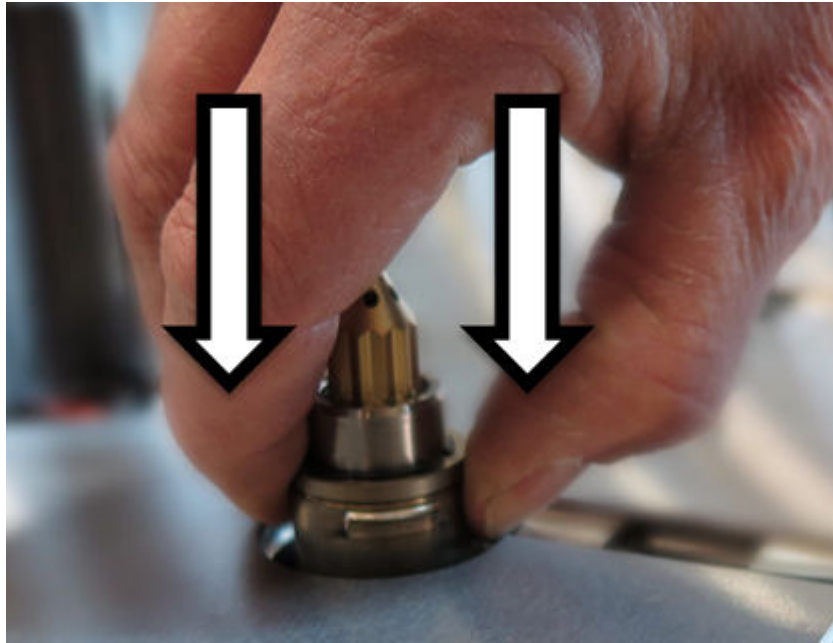

Figure 6-27: Heater/ Thermocouple Spring Back to Retaining Ring

NOTE:

If the heater and thermocouple do not spring back to the snap ring or maintain contact with each other, the bends in the wiring may be at fault.

- Wire routing must not over constrain heater positioning on nozzle.
- Wiring contacting a wire groove clip can restrict spring-back motion.
- Adjust wiring by pushing it down towards the bottom of the wire groove.
- Wiring must not protrude above the plate surface.

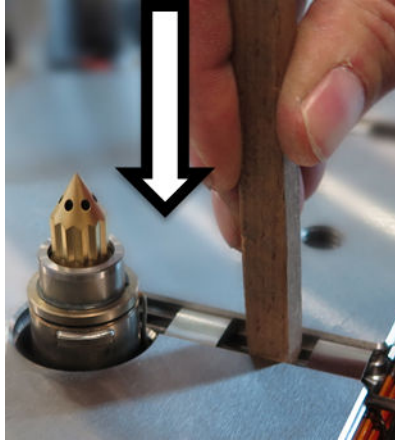

Figure 6-28: Wiring Placement in Groove

NOTE:

Proper operation of the Ultra Nozzle Heater requires the force of the wave spring to maintain contact between the thermocouple ring and nozzle heater. Improper installation may result in processing issues.

8. Make sure to stagger the knuckles in the wire grooves.



Figure 6-29: Staggering the Knuckles in the Wire Grooves

NOTE:

All wire, including heater or thermocouple wire, that could contact a heated component such as a nozzle housing or manifold must be mineral insulated high temperature wire (hard lead). If the mineral insulated lead is not long enough to allow this, additional steps must be taken, such as using high temperature sleeving, to prevent the knuckles and PTFE or Kapton insulated wire (soft lead) from overheating.

9. Label each wire with the heater zone number. Refer to the electrical schematic for the zone number.

10. Crimp the wire ends and connect the wires to the appropriate multi-pin connectors. Refer to the electrical schematic for more information.
11. Test each nozzle heater. Refer to [Section 6.13](#) for more information.
12. Remove all locks and tags. Refer to [Section 2.5](#) for more information.

6.10.3 Removing and Installing Bi-Metal Heaters on U750 and U1000 Systems

The following procedures describe how to remove and install bi-metal nozzle heaters on U750 and U1000 systems.

6.10.3.1 Removing Bi-Metal Nozzle Heaters on U750 and U1000 Systems

To remove a bi-metal nozzle heater, do the following:

1. Separate or remove the cavity plate from the manifold.
2. Remove the nozzle retainer.
3. Remove the front ring.

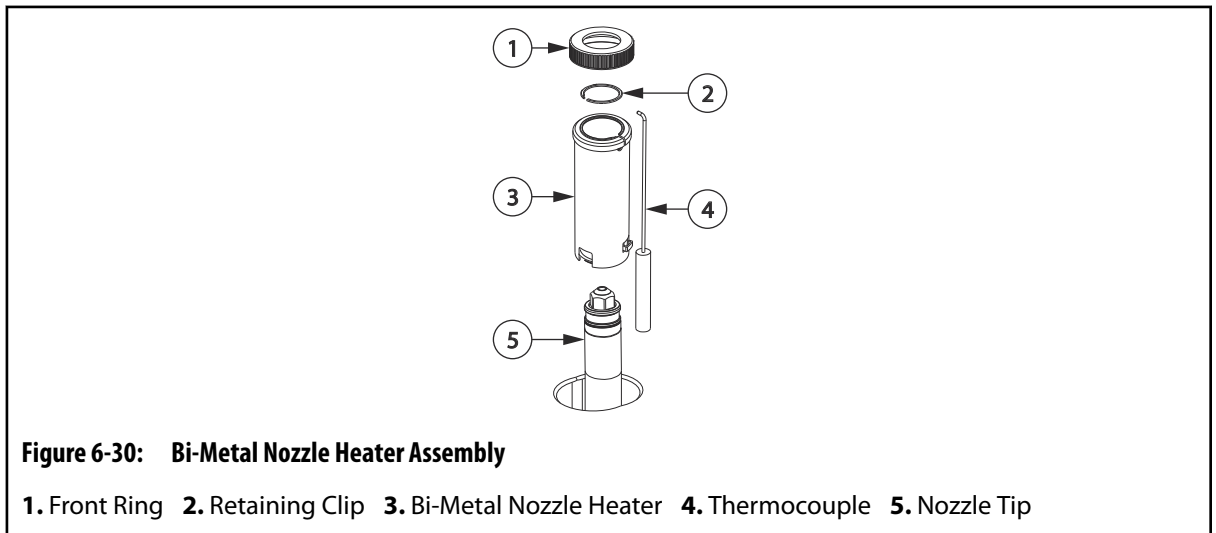

4. Disconnect the thermocouple from the nozzle heater.
5. Remove the retaining clip from the nozzle tip.
6. Remove the necessary wire clips to expose the nozzle heater and thermocouple wires.
7. Remove the nozzle heater and thermocouple.

6.10.3.2 Installing Bi-Metal Nozzle Heaters on U750 and U1000 Systems

To install a bi-metal nozzle heater, do the following:

1. Separate or remove the cavity plate from the manifold.
2. Remove the nozzle retainer.

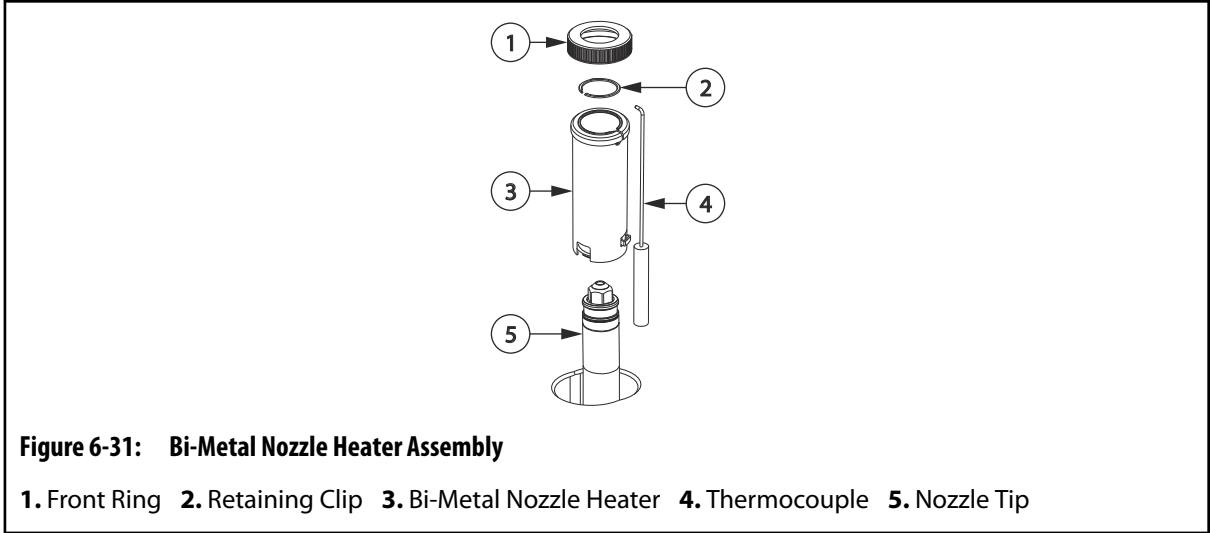

3. Install the retaining clip around the nozzle tip.
4. Connect the thermocouple to the nozzle heater.
5. Pull the nozzle heater up against the retaining clip.
6. Install the front ring and tighten it by hand.
7. Route the nozzle heater and thermocouple wires through the wire passages on the nozzle retainer.



Figure 6-32: Routing the wires

1. Nozzle Retainer **2.** Nozzle Retainer Wire Passage **3.** Wire Channel

- 8.** Install the nozzle retainer but do not tighten it.
- 9.** Route the wires into the wire channel on the manifold frame. Make sure all wiring is properly retained in the wire channel using wire clips.
- 10.** Tighten the nozzle retainer.
- 11.** Make sure to stagger the knuckles in the wire grooves.



Figure 6-33: Staggering the Knuckles in the Wire Grooves

NOTE:

All wire, including heater or thermocouple wire, that could contact a heated component such as a nozzle housing or manifold must be mineral insulated high temperature wire (hard lead). If the mineral insulated lead is not long enough to allow this, additional steps must be taken, such as using high temperature sleeving, to prevent the knuckles and PTFE or Kapton insulated wire (soft lead) from overheating.

12. Label each wire with the heater zone number. Refer to the electrical schematic for the zone number.
13. Crimp the wire ends and connect the wires to the appropriate multi-pin connectors. Refer to the electrical schematic for more information.
14. Test each nozzle heater. Refer to [Section 6.13](#) for more information.

6.10.4 Removing and Installing Triton Heaters on U750-UP Systems

The following procedures describe how to remove and install Triton nozzle heaters on U750-UltraPackaging (UP) Systems.

6.10.4.1 Removing Triton Nozzle Heaters on U750-UP Systems

To remove a Triton nozzle heater, do the following:

1. Separate or remove the cavity plate from the manifold.
2. Remove the nozzle retainer.
3. While holding the retaining clip and nozzle heater firmly against the wave springs, remove the retaining clip from the nozzle tip.

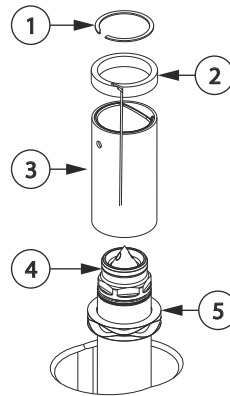

Figure 6-34: Triton Heater Assembly

1. Retaining Clip 2. Thermocouple and Retaining Ring 3. Triton Nozzle Heater 4. Nozzle Tip 5. Wave Spring

4. Remove the necessary wire clips to expose the nozzle heater and thermocouple wires.
5. Disconnect the thermocouple and retaining ring from the nozzle heater.
6. Remove the thermocouple and retaining ring from the nozzle heater.
7. Remove the nozzle heater.
8. Remove and inspect the wave springs. Discard the wave springs if they are compressed by more than 3 mm (0.12 in) or show signs of wear or damage.

6.10.4.2 Installing Triton Nozzle Heaters on U750-UP Systems

To install a Triton nozzle heater, do the following:

1. If required, separate or remove the cavity plate from the manifold.
2. Remove the nozzle retainer.
3. If the wave springs were discarded when removing the nozzle heater, install new wave springs over the nozzle housing and nozzle tips.

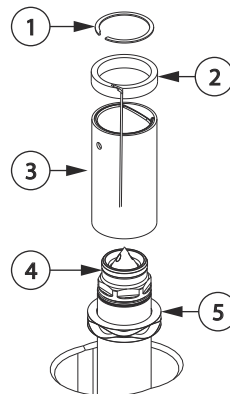

Figure 6-35: Triton Heater Assembly

1. Retaining Clip 2. Thermocouple and Retaining Ring 3. Triton Nozzle Heater 4. Nozzle Tip 5. Wave Spring

4. Slide the nozzle heater over the nozzle housing far enough to show the retaining clip groove on the nozzle tip.
5. Slide the thermocouple and retaining ring over the nozzle tip, onto the nozzle heater, far enough to show the retaining clip groove on the nozzle tip.
6. Orient the thermocouple wires on the same side as the nozzle heater wires.
7. While holding the nozzle heater and thermocouple and retaining ring firmly against the wave springs, install the retaining clip into the groove in the nozzle housing.
8. Install the nozzle retainer but do not tighten it.
9. Route the nozzle heater and thermocouple wires through the wire passages on the nozzle retainer.



Figure 6-36: Routing the wires

1. Nozzle Retainer 2. Nozzle Retainer Wire Passage 3. Wire Channel

10. Tighten the nozzle retainer.
11. Route the wires into the wire channel on the manifold frame. Make sure all wiring is properly retained in the wire channel using wire clips.
12. Make sure to stagger the knuckles in the wire grooves.



NOTE:

All wire, including heater or thermocouple wire, that could contact a heated component such as a nozzle housing or manifold must be mineral insulated high temperature wire (hard lead). If the mineral insulated lead is not long enough to allow this, additional steps must be taken, such as using high temperature sleeving, to prevent the knuckles and PTFE or Kapton insulated wire (soft lead) from overheating.

13. Label each wire with the heater zone number. Refer to the electrical schematic for the zone number.
14. Crimp the wire ends and connect the wires to the appropriate multi-pin connectors. Refer to the electrical schematic for more information.
15. Test each nozzle heater. Refer to [Section 6.13](#) for more information.

6.10.5 Removing and Installing HTM Nozzle Heaters for U1000 Systems

The following procedures describe how to remove and install HTM nozzle heaters for U1000 systems.

6.11 Replacing the Hydraulic or Pneumatic Manifold Hoses

Husky recommends that hydraulic or pneumatic manifold hoses be replaced after three years of operation. Contact Husky for more information about the options below.

- To replace the hoses, return the Unify system to Husky. Husky will assemble, correctly route and test the new hoses.
- Order a complete hose package from Husky.
- To order a single hose, contact Husky support and provide the following information for the hose that needs to be replaced: drop number, fluid type, open/close (for hydraulic fluid), or in/out (for water).

6.12 Grounding the Unify System

When the Unify system is installed in the mold plates, a path to ground exists through the manifold assembly and into the mold plates. However, when the system is removed from the mold plates for bench testing, a separate ground wire must be installed and connected to ground.

To install a separate ground wire for testing, do the following:



WARNING!

Electrical hazard - risk of death or serious injury. The Unify system must be grounded when it is removed from the plates for bench testing. Either of the ground tap locations can be used for the full manifold assembly, but if the frame is removed from the manifold then both locations must be used.

1. Connect the ground wire to one of the two ground taps. Connect one wire to the manifold surface and one wire on the electrical box mounting plate. Both locations are clearly marked with a protective conductor terminal symbol. Refer to [Figure 6-38](#).
2. If the frame is removed from the manifold, connect the ground wire to both of the ground taps.

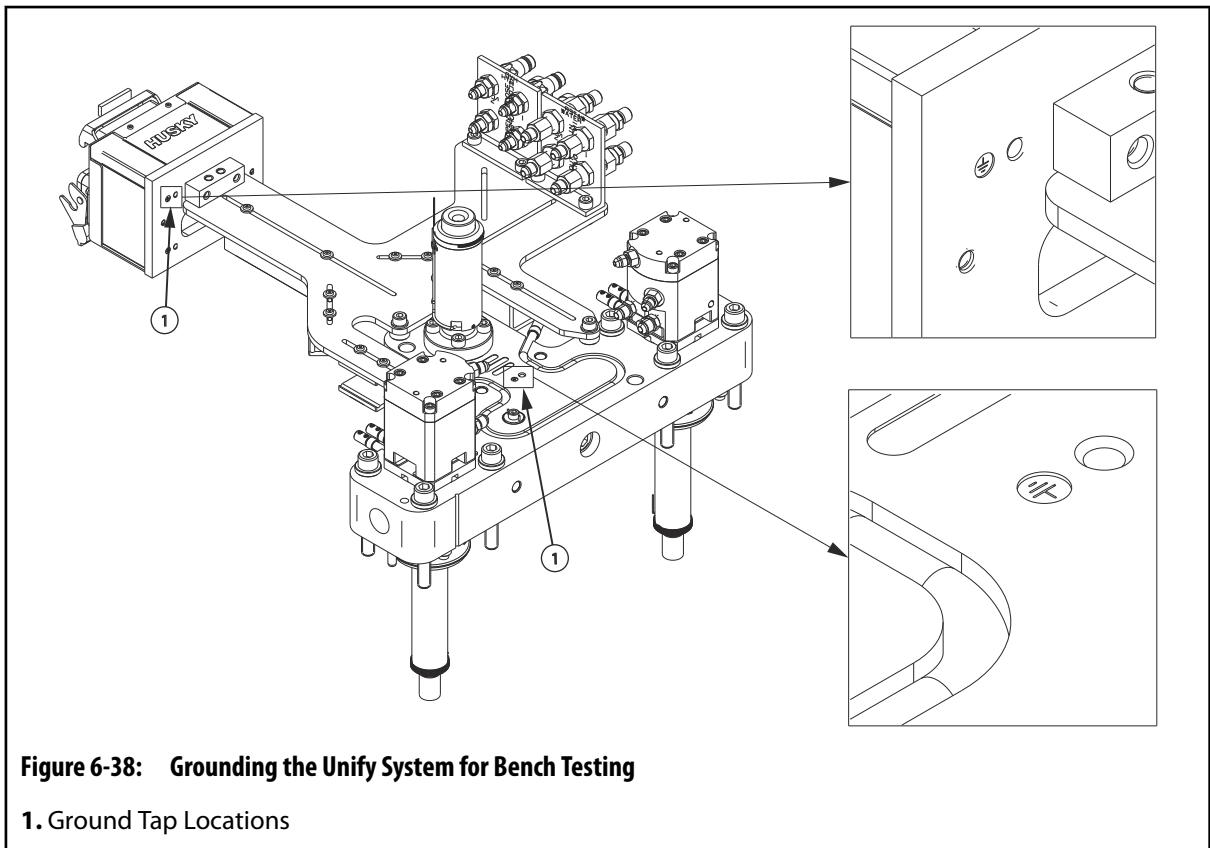

Figure 6-38: Grounding the Unify System for Bench Testing

1. Ground Tap Locations

6.13 Testing Heaters

To confirm a heater is functioning properly, do the following:

1. Make sure the system is grounded correctly. Refer to [Section 6.12](#) for more information
2. With the heater at or near room temperature, use an ohmmeter to measure the resistance through the heater. Refer to the electrical schematic for the required ohms measurement.

The normal tolerance for all heaters is $\pm 15\%$.



IMPORTANT!

A common problem with heaters is moisture absorption due to the hygroscopic nature of the insulation. A heater with a low case to center conductor insulation reading ($< 10K \Omega$) should be baked out and retested to determine if moisture was the cause. Contact Husky for more information.

-
3. Using an ohmmeter, measure the resistance through each lead to ground. A measurement from either lead to ground that is below $100K \Omega$ indicates a short to ground. A measurement from $100K \Omega$ to $1M \Omega$ is often associated with a wet heater.

A measurement greater than $1M \Omega$ is good.

NOTE:

A short reading can be the result of either a pinched wire or a broken heater element. Inspect the wires first to make sure there are no pinched or damaged lead wires. A heater wire can be spliced, however, this should only be done by a certified electrician. The splice should include dual layer heat shrink tubing with an adhesive inner layer to avoid potential water shorts. The heat shrink should be rated for $150 \text{ }^\circ\text{C}$ ($203 \text{ }^\circ\text{F}$) minimum.

NOTE:

Refer to the electrical schematics for resistance information.

6.14 Removing and Installing the Cavity Plate

Removing the cavity plate provides access to wiring, nozzle tips, nozzle heaters and gates. The cavity plate can be removed when the mold and hot runner assembly is in the machine or on a work bench.

CAUTION!

Risk of damage to the sealing surfaces. Hot runner nozzles must be at room temperature (<25 °C or <77 °F) before removing or installing the cavity plate to avoid damage to the sealing surfaces.

6.14.1 Removing the Cavity Plate On a Work Bench

To remove the cavity plate from the hot runner when the assembly is on a work bench, do the following:

NOTE:

The following procedure requires the use of an overhead lifting device. Refer to [Section 4.1](#) for lifting and handling instructions.

CAUTION!

Mechanical hazard – risk of damage to the hot runner. Make sure all valve stems are in the open position during tool shutdown.

1. Remove the hot runner and cavity plate assembly from the machine and set it on a work bench with the nozzles facing up. Refer to [Section 4.2](#) for more information.

CAUTION!

Mechanical hazard – risk of damage to the nozzle sealing surfaces. The temperature of the nozzle tips must cool to room temperature <25 °C (<77 °F) before the cavity plate is removed. Damage to the nozzle sealing surfaces will occur if the temperature is too high.

2. Remove the screws that secure the cavity plate to the hot runner.



WARNING!

Crushing hazard – risk of death or serious injury. Inadequate lifting equipment can fail and could cause death or serious injury. Make sure all lifting equipment is rated for the load and in safe operating condition.

3. Install hoist rings in the designated lifting points marked on the cavity plate.

CAUTION!

Mechanical hazard – risk of damage to the mold and hot runner. Lift the cavity plate slowly until the alignment dowels are cleared. Damage to the cavity plate and/or alignment dowels could occur.

4. Attach an overhead lifting device to the hoist rings and lift the cavity plate. Use the pry slots between the plate and hot runner to help separate the cavity plate.

**WARNING!**

Crushing hazard – risk of death or serious injury. Do not work under suspended loads. To prevent injury, install safety blocks.

5. If equipped, install feet on the bottom of the cavity plate to protect the hose fittings.
6. Move the cavity plate out of the work area. Store the plate in a location where the plate cannot fall or tip over.
7. If equipped, remove the nozzle tip insulators from the nozzle tips and/or cavity plate. Refer to [Section 6.19](#) for more information.
8. Remove any insulating gate bubbles on the nozzle tips or in the cavity plate gate details. Refer to [Section 6.16](#) for more information.

6.14.2 Installing the Cavity Plate On a Work Bench

To secure the cavity plate to the hot runner when the assembly is on a work bench, do the following:

NOTE:

The following procedure assumes the cavity plate was removed as described in [Section 6.14.1](#)

NOTE:

The following procedure requires the use of an overhead lifting device. Refer to [Section 4.1](#) for lifting and handling instructions.

CAUTION!

Mechanical hazard – risk of damage to the hot runner. Make sure all valve stems are in the still in the open position prior to installation.

1. Make sure the hot runner is on a work bench with the nozzle tips facing up. The hot runner must be supported by two blocks.
2. Make sure the nozzle and cavity plate sealing diameters are clean and free of burrs or oil.

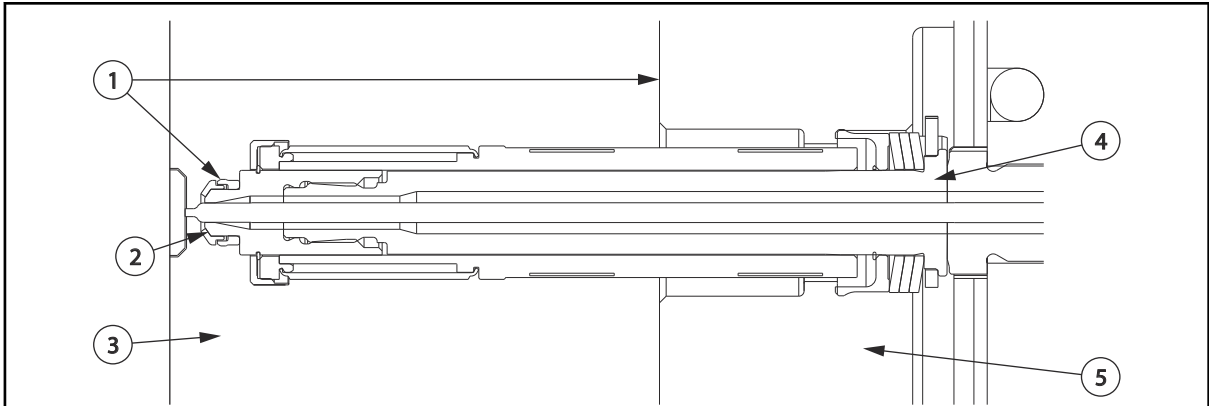

Figure 6-39: Cavity and Nozzle Sealing Diameters

1. Nozzle and Cavity Plate Sealing Diameters 2. Gate Bubble 3. Cavity Plate 4. Nozzle Housing 5. Manifold Plate

- 3. Apply a static application grease to the hot runner alignment dowels. Refer to [Section 3.9](#) for information about recommended lubricants.
- 4. If equipped, install a nozzle tip insulator on each nozzle tip. Refer to [Section 6.19](#) for more information.



WARNING!

Crushing hazard – risk of death or serious injury. Inadequate lifting equipment can fail and cause death or serious injury. Make sure all lifting equipment is rated for the load and in safe operating condition.

- 5. Install hoist rings in the designated lifting points marked on the cavity plate.
- 6. Attach an overhead lifting device to the hoist rings and lift the cavity plate over the hot runner.



IMPORTANT!

When assembling the cavity plate to the hot runner, special attention should be given to preventing damage to the nozzle tips, valve stems and wires. The cavity plate should mate with the hot runner without any resistance. If resistance is encountered, remove the plate and check for any interference points.

CAUTION!

Mechanical hazard – risk of damage to equipment. Do not force the plate into position as serious damage to the nozzle tips, valve stems and wires can result.

CAUTION!

Mechanical hazard – risk of damage to the mold and hot runner. The nozzles and manifold must be at room temperature (< 25 °C or < 77 °F) before the cavity plate is connected to the hot runner. Severe damage to the nozzle and cavity plate sealing diameters can result if the mold is still hot.

7. Align the cavity plate with the alignment dowels and lower the plate onto the hot runner. Make sure the wires in the wire channels are not pinched between the plates while closing.
8. Disconnect the overhead lifting device and remove the hoist rings.
9. Remove the feet from the bottom of the cavity plate.
10. Install safety latch bars between the cavity plate and hot runner on both sides of the assembly. A minimum of two safety latch bars are required.
11. Install the screws that secure the cavity plate to the hot runner and torque them to the specified value. Refer to the manufacturer's documentation for torque requirements.
12. Check the electrical circuit with an ohmmeter to make sure no wires were damaged during installation. Refer to the electrical schematic to identify each zone.

6.14.3 Removing the Cavity Plate In the Machine

To remove the cavity plate from the hot runner when the assembly is in the machine, do the following:



WARNING!

Hot resin spray hazard – risk of serious injury. Residual pressure from gases in the hot runner could cause hot resin to spray from the nozzle tips when released. Make sure the valve gates are open when turning off the heaters to relieve pressure in the hot runner.

CAUTION!

Mechanical hazard – risk of damage to the hot runner. Do not actuate the valve stems when the hot runner is cold. Damage to the valve stems could occur.

1. Open the valve gates.
2. Cool the mold by running coolant through it until the hot runner nozzles and manifold(s) are at room temperature (< 25 °C or < 77 °F). This may take 1/2 to 4 hours depending on the size of the hot runner.
3. Open the clamp.
4. Lock out and tag the machine and controller (if equipped). Refer to [Section 2.5](#) for more information.
5. Purge all cooling water from the cooling hoses to minimize the risk of a coolant spill should a hose come loose during maintenance. Refer to the machine manufacturer's documentation for more information.

6. Install safety latch bars between the cavity plate and hot runner on both sides of the assembly. A minimum of two safety latch bars are required.

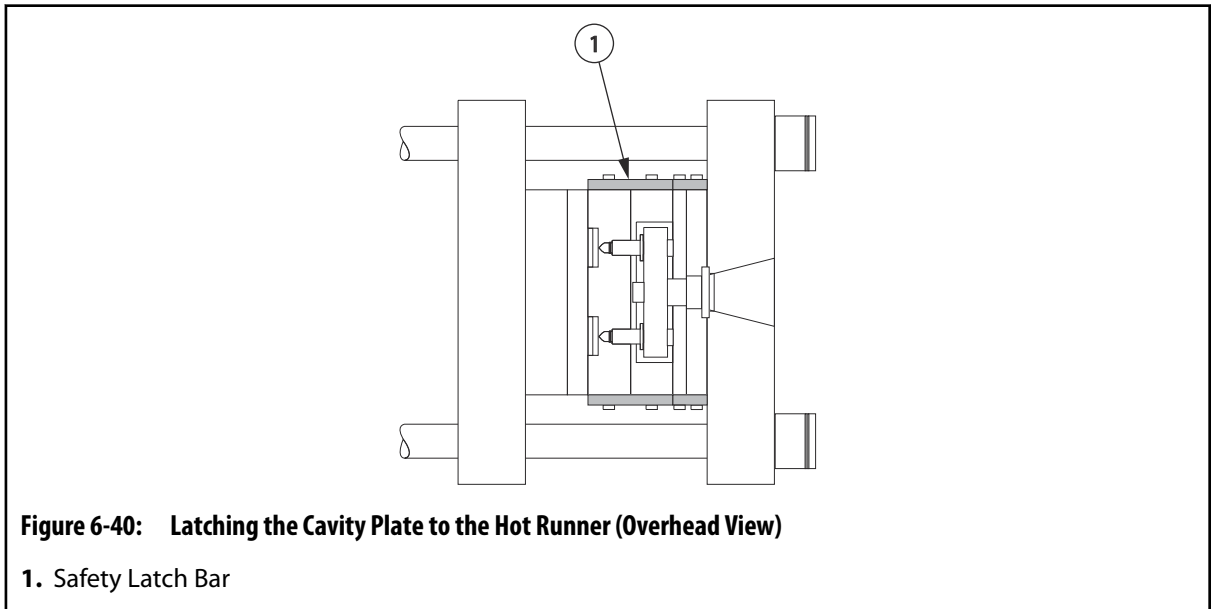

CAUTION!

Mechanical hazard – risk of damage to the nozzle sealing surfaces. The temperature of the nozzle tips must cool to room temperature <25 °C (<77 °F) before the cavity plate is removed. Damage to the nozzle sealing surfaces will occur if the temperature is too high.

7. Remove the screws that secure the cavity plate to the hot runner.
8. Remove all locks and tags.
9. Reduce the clamp opening and closing speed.
10. Slowly close the clamp.
11. Lock out and tag the machine and controller (if equipped).
12. Remove all safety latch bars.

CAUTION!

Mechanical hazard – risk of damage to the machine, mold and hot runner. Make sure the hoses attached to the cavity plate are long enough to allow latching without damaging the hoses. In some cases it may be necessary to relieve residual pressure in the system and then disconnect the hoses.

13. Install safety latch bars between the cavity plate and core plate on both sides of the assembly. A minimum of two safety latch bars are required.
14. Remove all locks and tags.

CAUTION!

Mechanical hazard – risk of damage to the mold and hot runner. The nozzles and manifold must be at room temperature (< 25 °C or < 77 °F) before the cavity plate is separated from the hot runner. Severe damage to the nozzle and cavity plate sealing diameters could result if the mold is still hot.

15. Open the clamp.
16. Lock out and tag the machine and controller (if equipped).
17. If equipped, remove the nozzle tip insulators from the nozzle tips and/or cavity plate. Refer to [Section 6.19](#) for more information.
18. Remove any insulating gate bubbles on the nozzle tips or in the cavity plate gate details. Refer to [Section 6.16](#) for more information.

6.14.4 Installing the Cavity Plate In the Machine

To secure the cavity plate to the hot runner when the assembly is in the machine, do the following:

NOTE:

The following procedure assumes the cavity plate was removed as described in [Section 6.14.3](#).

1. Lock out and tag the machine and controller (if equipped). Refer to [Section 2.5](#) for more information.
2. Make sure the nozzle and cavity plate sealing diameters are clean and free of burrs or oil.

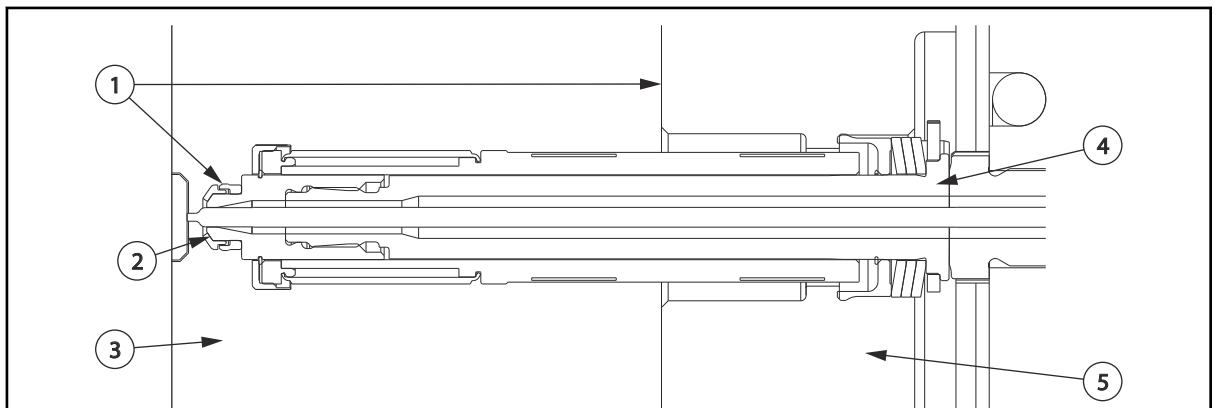

Figure 6-41: Cavity and Nozzle Sealing Diameters

1. Nozzle and Cavity Plate Sealing Diameters
 2. Gate Bubble
 3. Cavity Plate
 4. Nozzle Housing
 5. Manifold Plate
3. Apply a static application grease to the hot runner alignment dowels. Refer to [Section 3.9](#) for information about recommended lubricants.
 4. If equipped, install the nozzle tip insulators. Refer to [Section 6.19](#) for more information.
 5. Remove all locks and tags.
 6. Reduce the clamp opening and closing speed.

CAUTION!

Mechanical hazard – risk of damage to the mold and hot runner. The nozzles and manifold must be at room temperature (< 25 °C or < 77 °F) before the cavity plate is connected to the hot runner. Severe damage to the nozzle and cavity plate sealing diameters could result if the mold is still hot.

7. Slowly close the clamp to move the cavity plate into position. Make sure the wires in the wire channels are not pinched between the plates while closing.
8. Lock out and tag the machine and controller (if equipped).
9. Remove all safety latch bars.
10. Install safety latch bars between the cavity plate and hot runner on both sides of the assembly. A minimum of two safety latch bars are required.

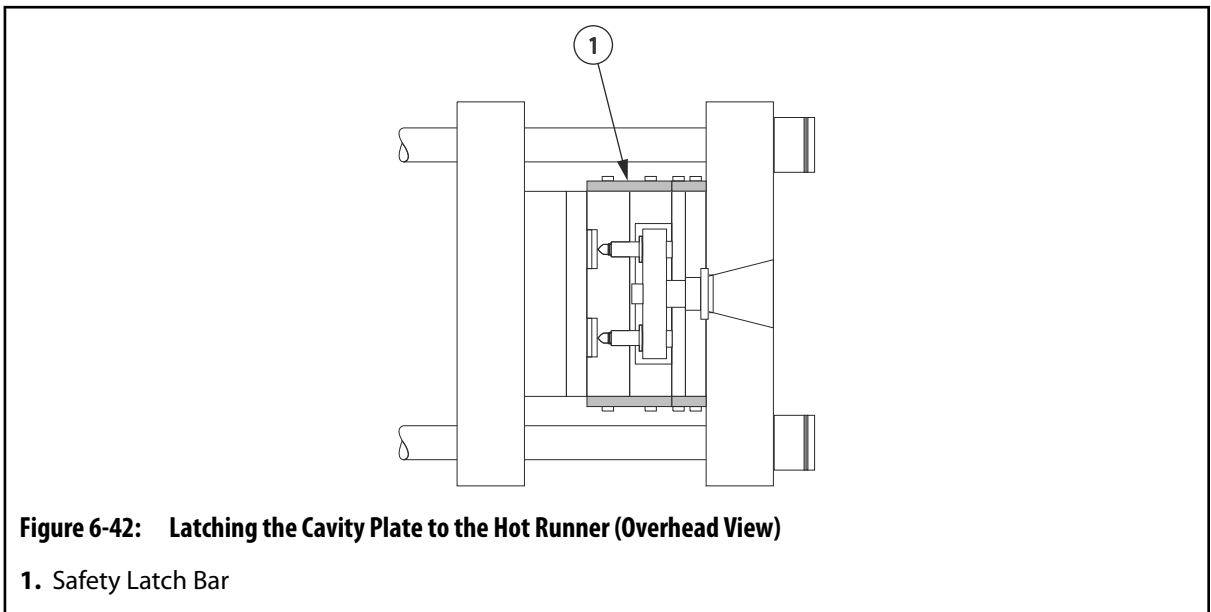

11. Remove all locks and tags.
12. Reduce the clamp opening and closing speed.
13. Slowly open the clamp to move the cavity plate away from the core plate.
14. Lock out and tag the machine and controller (if equipped).
15. Install the screws that secure the cavity plate to the hot runner and torque them to the specified value. Refer to the manufacturer's documentation for torque requirements.
16. Remove all safety latch bars.
17. Check the electrical circuit with an ohmmeter to make sure no wires were damaged during installation. Refer to the electrical schematic to identify each zone.

6.15 Inspecting and Cleaning Manifolds

To inspect and clean a manifold, do the following:

NOTE:

A fluidized bed cleaning process is recommended for cleaning manifolds and manifold components.

1. Clean the manifold in a fluidized bed. Refer to [Section 6.15.1](#) for more information.
However, if fluidized bed cleaning is unavailable, do the following:
 - a. Using brass scrapers, remove any resin left protruding from the manifold. Do not damage the sharp corners or sealing surfaces.
 - b. Clean the manifold bushing and seating surfaces using brass scrapers. Do not damage the sharp corners or sealing surfaces.
 - c. Remove all resin from the backup pads and manifold pocket.
 2. Clean the mating surfaces on the manifold with a medium India stone (240 grit oilstone). Do not scratch the manifold.
 3. Make sure all contact surfaces on the manifold plate and manifold bushings are clean and free of resin, scratches, nicks or burrs.
 4. Clean the mating surfaces on the manifold insulators with a medium India stone (240 grit oilstone). Do not scratch the manifold insulators.
-

CAUTION!

Mechanical hazard – risk of damage to the nozzle housings. Do not hone the back surface of the nozzle housing to remove nicks and burrs. The back surface is a precision made section of the housing with a contoured surface. Honing this section will cause the system to leak and void the leak proof guarantee for the hot runner.

5. Inspect the nozzle housings. Make sure they are free of nicks, burrs and any resin, especially in the melt channels. If the sealing surfaces are damaged in any way, replace the nozzle housings.
 6. Make sure the manifolds are clean and flat.
-

NOTE:

Use only Husky recommended high temperature power and thermocouple wire.

NOTE:

Refer to the electrical schematic when replacing wiring.

7. Check all manifold, heater and thermocouple wiring. Replace as necessary.
-

6.15.1 Cleaning Using a Fluidized Bed Process

The following sections describe fluidized bed cleaning and how to prepare the hot runner.

Cleaning the manifold passages is rarely required. However, if necessary, manifold passages must be cleaned using the fluidized bed process. Only the fluidized bed cleaning process will successfully remove the resin completely from the melt channels of the hot runner components.

Fluidized bed cleaning is a process with aluminum oxide particles in a high temperature retort. The heated air at 343 to 454 °C (650 to 850 °F) levitates the aluminum oxide particles creating a liquid-like behavior. The temperature and flow of the fluidized bed pyrolyzes (thermally decomposes) the polymer.

NOTE:

Husky does not recommend using a fluidized bed to clean mold plates and components.

6.15.1.1 Assistance

Husky provides a full system repair and cleaning service, in addition to helping customers find a local fluidized bed cleaning process.

Contact your nearest Husky Regional Service and Sales office for more information.

6.15.1.2 Disassembling the Hot Runner for Fluidized Bed Cleaning

When disassembling a hot runner for fluidized bed cleaning, do the following:



IMPORTANT!

Before disassembling a hot runner for fluidized bed cleaning, please note the following:

- When removing resin from the mold, make sure the faces of the manifold are kept scratch free. Scratches around the nozzle housing, valve bushing, manifold bushing and piston cylinder, or sprue bushing/sprue bar surfaces may cause severe resin leakage.
- The thickness of the manifold(s) is extremely important for the performance of the hot runner. There is a risk that cleaning the surface through grinding or sanding would change the total height of the stack and thereby increase the cold clearance. This would result in a resin leak.



IMPORTANT!

The fluidized bed cleaning process will anneal Beryllium Copper (BeCu), causing rapid failure of the components when returned to service.

Mechanical cleaning of BeCu components must not damage any of the sealing surfaces. Use only soft brass, hardwood sticks, Scotch-Brite, or soft brass brushes. Do not use abrasive methods to clean BeCu components.

**WARNING!**

Poison hazard - risk of death or serious injury. Do not use abrasives in an open air environment to clean BeCu components. Airborne beryllium particles are known carcinogens. Only rework BeCu components using abrasives under flood coolants to prevent airborne particles.

**IMPORTANT!**

The Husky Warranty does not cover BeCu components used outside the operating temperature range, or cleaned using the fluidized bed process.

CAUTION!

Do not remove any surface or melt channel plugs. This will void the leak proof guarantee for the hot runner. Plugs can only be removed by Husky.

1. Any system that is to be sent for fluidized bed cleaning is to be completely disassembled. However do not send the following items for cleaning:
 - Set screws
 - Polyetheretherketone (PEEK) bushings (refer to [Section 6.15.1.3](#)) or ceramic bushings
 - Surface hex head plugs
 - Nozzle tip insulators
 - Nozzle heaters
 - Sprue bushing heaters
 - Beryllium Copper (BeCu) components, such as manifold bushings, manifold inserts, some nozzle tips and tip retainers, etc.
-

NOTE:

Contact Husky for verification of the component's material before cleaning it with a fluidized bed process.

2. Make sure all electrical wiring and thermocouples are removed.
3. When packing for shipment, make sure the manifold heater ends do not get damaged during shipping.

The best method is to pack the manifold in a crate where it cannot move, or place the manifold between two pieces of plywood cut approximately 50 mm (2 in) larger all around. Hold the manifold and plywood pieces together with bolts using existing hold down holes or clearance holes in the manifold. Only use plywood thick enough to protect the manifold and absorb impacts if the manifold is dropped.

4. Send a complete packing list of all the components shipped to make sure nothing is overlooked when the components are returned.

6.15.1.3 Removing the PEEK Bushings

Due to the extreme temperatures in a fluidized bed (454 °C or 850 °F), Polyetheretherketone (PEEK) bushings must be removed from the manifold heater ends. The PEEK bushings will melt if subjected to the cleaning process.

To remove the PEEK bushings, twist the bushings 1/4 turn to break the adhesive used to attach it.



Figure 6-43: PEEK Bushing Removal and Installation

The bushings must be installed after the fluidized bed cleaning process. New adhesive is not necessary.

6.16 Removing Insulating Gate Bubbles (If Equipped)

In place of nozzle tip insulators, some hot runners form a bubble of resin at the nozzle tip referred to as an insulating gate bubble. The bubbles provide thermal insulation between the nozzle tip and the cold cavity plate steel. They also increase the speed of color changes and prevent the degradation of some heat sensitive resins. The gate bubble needs to be removed if the gate hole is blocked by contamination.

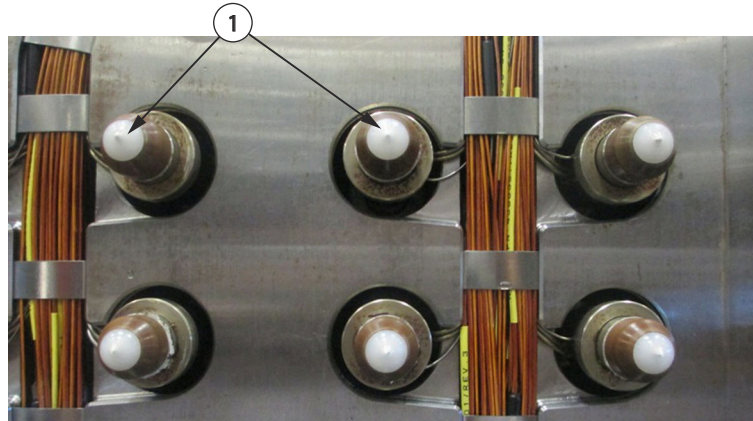

Figure 6-44: Gate Bubbles

1. Gate Bubbles

To remove the insulating gate bubbles, do the following:

1. Remove the cavity plate. Refer to [Section 6.14](#) for more information.
2. Connect the hot runner to a controller.
3. Turn on the controller.



DANGER!

Electrocution hazard – risk of serious injury and/or damage to the hot runner. Do not turn on the heaters if water has leaked into the hot runner. If water has leaked into the hot runner, the hot runner must be completely disassembled, dried and assembled before the heaters are turned on.



WARNING!

Hot resin spray hazard – risk of serious injury. Hot resin may unexpectedly spray from the nozzle tips while the hot runner is reaching operating temperature. To avoid serious burns, wear personal protective equipment consisting of a heat-resistant coat, heat-resistant gloves and a full face shield over safety glasses. Use adequate ventilation for fumes.



WARNING!

Burn hazard – risk of serious injury. Hot runner components stay hot for long periods of time after heaters have been turned off. Wear personal protective equipment when working near the hot runner and place a warning sign in the area before leaving the hot runner unattended.

4. Increase the temperature of a row of nozzle tips to a temperature high enough to soften the insulating gate bubble.

NOTE:

The Vicat Softening Temperature for the resin type is recommended. Refer to the resin supplier’s documentation for more information.

5. Once the nozzle tips have reached their setpoint approximately 120 °C (248 °F), wait until the gate bubble on the first nozzle tip is soft enough to remove and then turn off all the nozzle tip heaters.



WARNING!

Electrocution hazard - risk of death or serious injury. Complete the lockout/tagout procedure of the electrical power source before disconnecting the electrical connectors.

6. Lock out and tag the electrical power source.



IMPORTANT!

Do not allow the nozzle tips to overheat or degraded material will have to be cleaned out of the nozzle housing before a new nozzle tip can be installed.

7. Disconnect the controller.
8. Remove all gate bubbles from the row with brass pliers, a clean cloth or a soft wire brush.
9. Repeat [step 4](#) to [step 8](#) for all subsequent rows.



WARNING!

Burn, fire and gas hazard – risk of death or serious injury, and property damage. Use of an open flame to remove resin could produce harmful gases (depending on the resin type), damage components and increase the risk of fire. Only use open flames sparingly and in a controlled environment.



WARNING!

Burn hazard – risk of serious injury. To avoid serious burns, wear personal protective equipment consisting of a heat-resistant coat, heat-resistant gloves, and a full face shield over safety glasses. Use adequate ventilation for fumes.

CAUTION!

Mechanical hazard – risk of damage to the equipment. Abrasives should never be used to clean the nozzle tips, as this could damage the critical sealing surfaces.

Do not remove the gate bubble with a hammer or tools made of hard material. Use tools made of soft materials such as brass, copper or wood. Hammering or using hard material tools could result in damage to the nozzle tips.

10. Remove any insulating gate bubbles in the cavity plate. If required, carefully heat the gate bubbles with a propane torch and then wipe the deposits away with a clean, soft cloth or soft wire brush. This may have to be repeated several times.

CAUTION!

Mechanical hazard – risk of damage to the hot runner. Do not allow molten resin to drop on or build up under the nozzle tip insulators while the gate bubbles are being removed. The additional material will increase the calculated preload for the nozzle tip insulator and damage the hot runner during assembly with the cavity plate.

Make sure all nozzle tip insulators are clean and seated correctly before installing the cavity plate.

-
11. Make sure all nozzle tip insulators (if equipped) are seated correctly with a minimal and even gap between the nozzle tip insulator and the nozzle housing. For reused nozzle tips, the gap may not be noticeable. When plastic is under the nozzle tip insulator, it will have a larger than usual and/or uneven gap in relation to the nozzle housing. If plastic is under the nozzle tip insulator it must be cleaned or replaced. For more information on removing and installing the nozzle tip insulator refer to [Section 6.19](#).



Figure 6-45: Seating the Nozzle Tip Insulator (Example)

To remove, clean and install the nozzle tip insulator, do the following:

- a. Mark the orientation of the nozzle tip insulator.
- b. Remove the nozzle tip insulator.

**IMPORTANT!**

If the nozzle tip insulator is damaged or cannot be cleaned then it must be replaced.

-
- c. Clean the nozzle tip insulator by heating to melt the residual plastic and wiping it clean.
 - d. Install the nozzle tip insulator. Nozzle tip insulators must be installed on the same nozzle tip in the original orientation.
12. Make sure the hot runner is at room temperature <math><25\text{ }^\circ\text{C}</math> (<math><77\text{ }^\circ\text{F}</math>).

NOTE:

If the hot runner is still in the machine the cooling water can be turned on to cool the hot runner down.

13. Install the cavity plate. Refer to [Section 6.14](#) for more information.

6.17 Removing and Installing the Sprue Heater (If Equipped)

The following procedures describe how to remove and install a sprue heater with a built-in thermocouple or a separate thermocouple.

6.17.1 Removing a Sprue Heater with a Built-In Thermocouple

To remove a sprue heater that has a built-in thermocouple, do the following:

1. If necessary, remove the hot runner from the machine. Refer to [Section 4.2.2](#) for more information.
2. Disconnect the sprue heater and thermocouple wires from the multi-pin connectors.

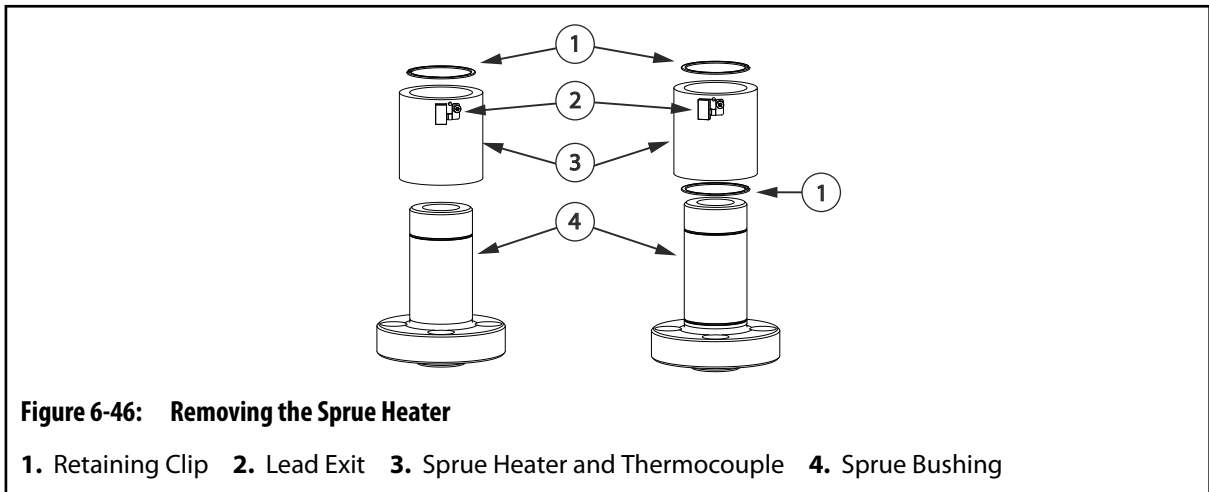

3. Remove the sprue heater and thermocouple wires from the wire channels in the manifold plate.
4. Remove the retaining clip from the sprue bushing.
5. Remove the sprue heater and thermocouple from the sprue bushing.

6.17.2 Removing a Sprue Heater with a Separate Thermocouple

To remove a sprue heater that has a separate thermocouple, do the following:

1. If necessary, remove the hot runner from the machine. Refer to [Section 4.2.2](#) for more information.
2. Disconnect the sprue heater and thermocouple wires from the multi-pin connectors.

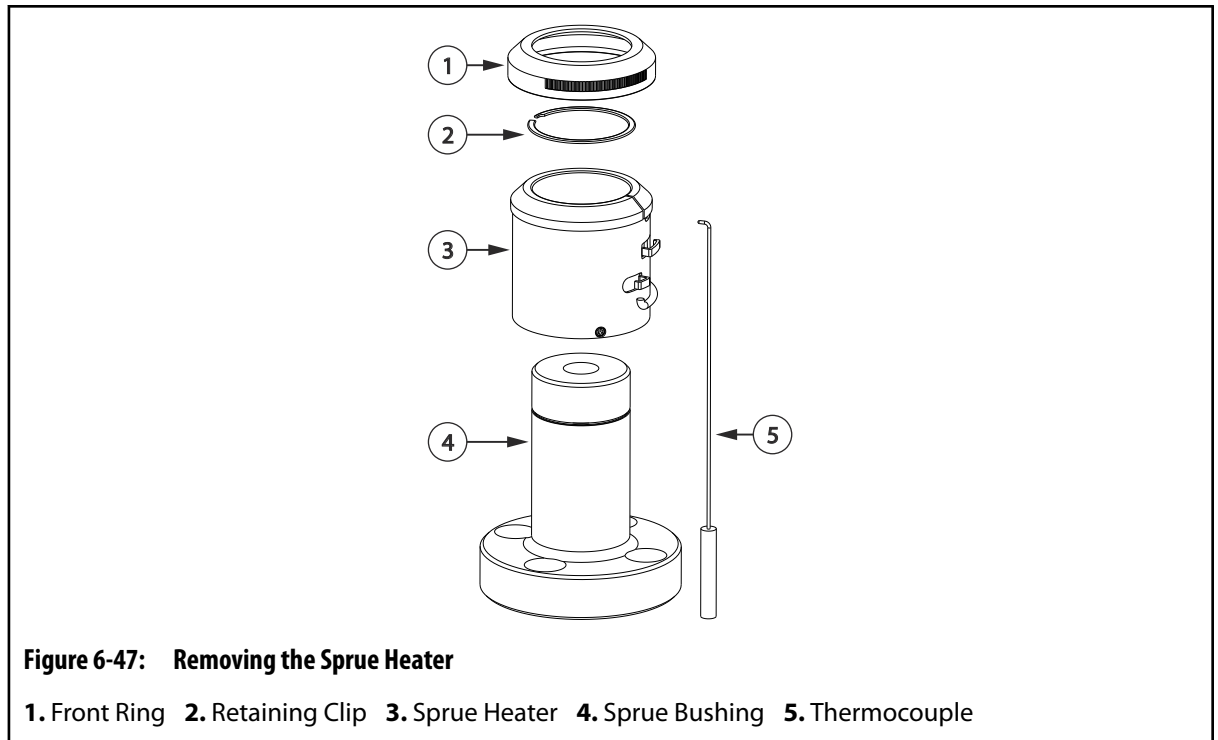

3. Remove the sprue heater and thermocouple wires from the wire channels in the manifold plate.
4. Remove the front ring, retaining clip and thermocouple.
5. Using a heater removal tool, remove the sprue heater from the sprue bushing. Refer to [Section 1.8](#) for a list of special Husky tools and order numbers.

6.17.3 Installing a Sprue Heater with a Built-In Thermocouple

To install a sprue heater with a built-in thermocouple, do the following:

1. If there are two retaining clip grooves, install a retaining clip in the groove closest to the manifold.
2. With the lead exit facing away from the manifold, slide the sprue heater onto the sprue bushing. Make sure the sprue heater is below the retaining clip groove in the sprue bushing.

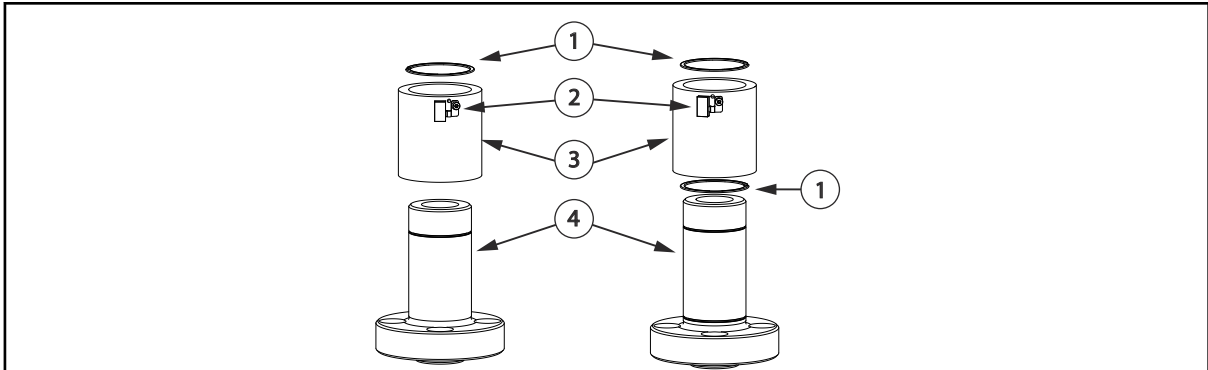

Figure 6-48: Installing the Sprue Heater

1. Retaining Clip 2. Lead Exit 3. Sprue Heater and Thermocouple 4. Sprue Bushing

3. Align the thermocouple wires with the wire channels in the backing plate.
4. Install the retaining clip into the groove on the sprue bushing.
5. Pull the sprue heater up until it makes contact with the retaining clip.

NOTE:

All wiring near the sprue heater must be either a high temperature braid or sleeved using a high temperature sleeving.

6. Route the sprue heater and thermocouple wires through the wire channels in the manifold plate. Make sure all wiring is properly retained in the wire channels using wire clips.
7. Label each wire with the heater zone number. Refer to the electrical schematic for the zone number.
8. Crimp the wire ends and connect them to the appropriate multi-pin connectors. Refer to the electrical schematic for more information.
9. Test the sprue heater. Refer to [Section 6.13](#) for more information.
10. Install the hot runner into the machine. Refer to [Section 4.2.1](#) for more information.

6.17.4 Installing a Sprue Heater with a Separate Thermocouple

To install a sprue heater with a separate thermocouple, do the following:

1. Slide the sprue heater onto the sprue bushing. Make sure the sprue heater is below the retaining clip groove in the sprue bushing.

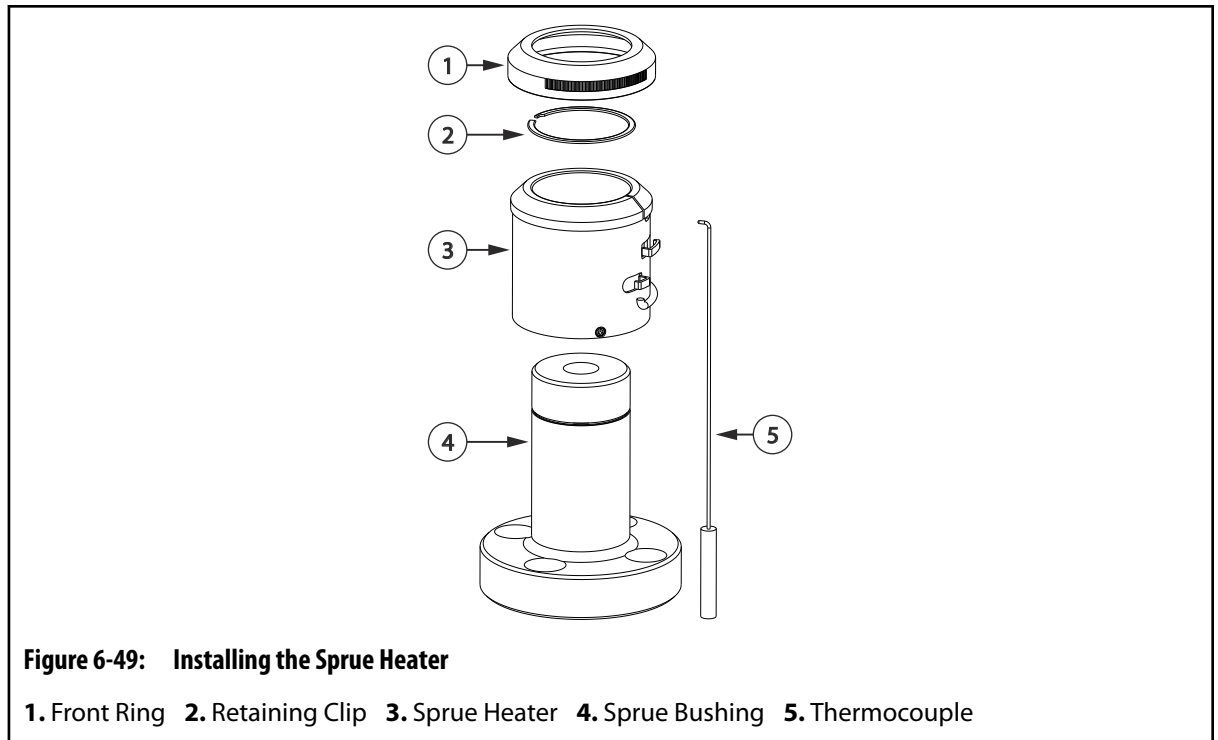

2. Install the retaining clip into the groove on the sprue bushing.
3. Using a heater removal tool, pull the sprue heater up until it makes contact with the retaining clip. Refer to [Section 1.8](#) for a list of special Husky tools and order numbers.

NOTE:

All wiring near the sprue heater must be either a high temperature braid or sleeved using a high temperature sleeving.

4. Connect the thermocouple to the sprue heater.
5. Route the sprue heater and thermocouple wires through the wire channels in the manifold plate. Make sure all wiring is properly retained in the wire channels using wire clips.
6. Thread the front ring onto the sprue heater and tighten by hand.
7. Label each wire with the heater zone number. Refer to the electrical schematic for the zone number.
8. Crimp the wire ends and connect them to the appropriate multi-pin connectors. Refer to the electrical schematic for more information.
9. Test the sprue heater. Refer to [Section 6.13](#) for more information.
10. Install the hot runner into the machine. Refer to [Section 4.2](#) for more information.

6.18 Removing and Installing the Sprue Bushing

The following procedures describe how to remove, maintain and install the sprue bushing.

6.18.1 Removing the Sprue Bushing

To remove the sprue bushing, do the following:

1. Remove the hot runner from the machine. Refer to [Section 4.2.2](#) for more information.
2. Remove the sprue heater. Refer to [Section 6.17](#) for more information.
3. Remove the screws that secure the sprue bushing to the manifold.

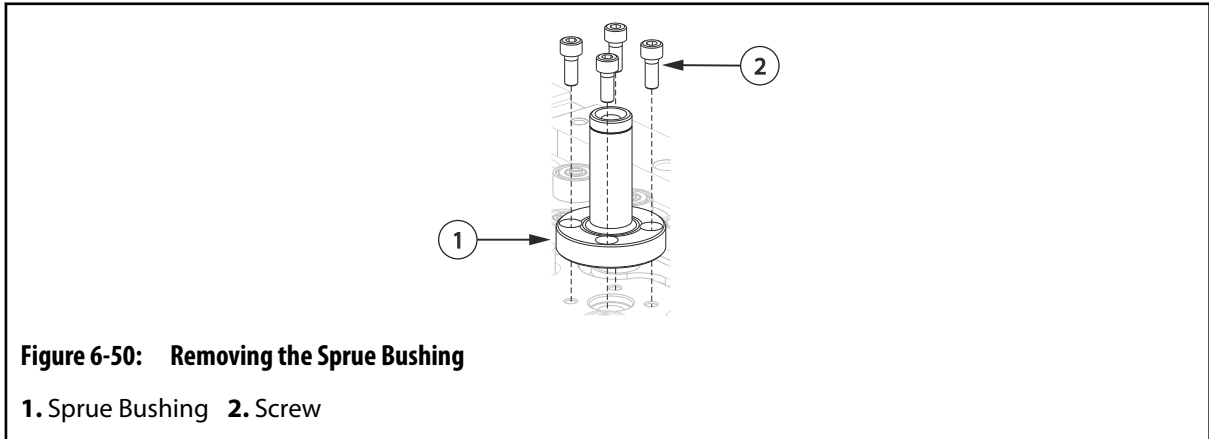

4. Remove the sprue bushing.
5. Using a brass rod, remove the resin slug from the sprue bushing melt channel.
6. Clean the sprue bushing. Do not damage any sealing surfaces.
7. Check and repair the nozzle radius, if required.

6.18.2 Installing the Sprue Bushing

To install the sprue bushing, do the following:



WARNING!

Hot resin spray hazard – risk of serious injury. Any contamination or damage at the sprue bushing and manifold interface may cause hot resin to spray out of the mold, possibly resulting in serious burns. Both the mounting faces of the sprue bushing and manifold must be spotlessly clean and undamaged. The mounting screws must also be torqued to the specified value.

NOTE:

The supplied screws used to install the sprue bushing are of a special quality and must not be substituted.

1. Clean the surfaces on the sprue bushing and manifold where the two components will interface.

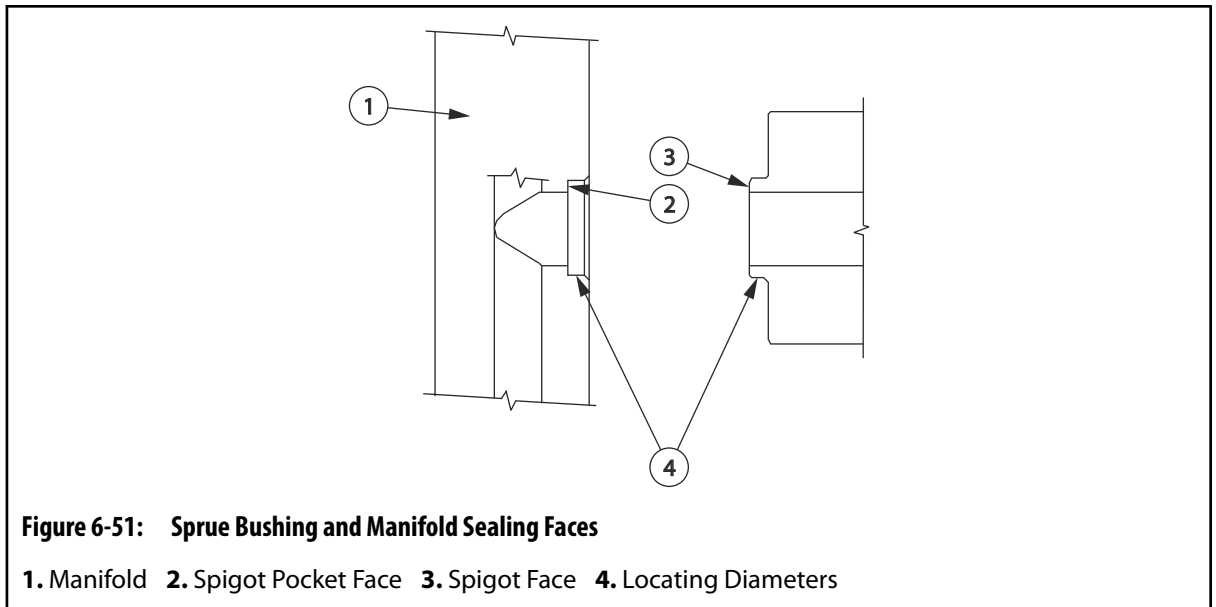
**CAUTION!**

Crushing hazard – risk of damage to equipment. Screws used to install the sprue bushing must meet specific requirements. Only use the screws specified in the assembly drawings. Failure to use these screws could result in equipment damage.

- Apply a high temperature anti-seize lubricant to the screws used to install the sprue bushing. Refer to [Section 3.5](#) for information about recommended lubricants.

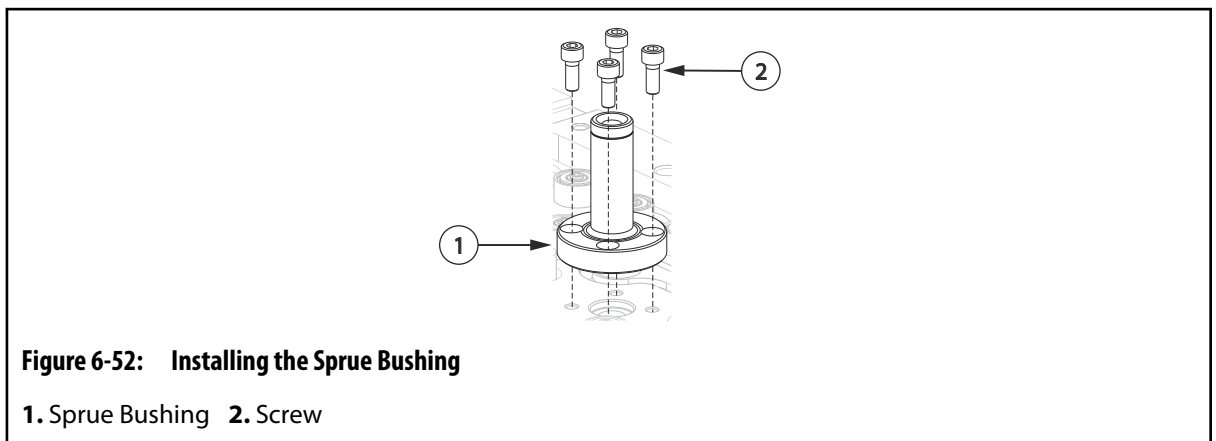

- Install the sprue bushing and torque all screws to half the specified value in a cross pattern. Refer to the assembly drawings for torque requirements.
- Torque the screws fully to the specified value to make sure an even seal is made between the sprue bushing and manifold. Refer to the assembly drawings for torque requirements.
- Install the sprue heater. Refer to [Section 6.17](#) for more information.
- Install the hot runner into the machine. Refer to [Section 4.2](#) for more information.

6.19 Removing and Installing Nozzle Tip Insulators (If Equipped)

Nozzle tip insulators protect the gate details and nozzle tips from damage and prevent resin leaks.

The following procedures describe how to remove and install nozzle tip insulators.

6.19.1 Removing the Nozzle Tip Insulators

To remove the nozzle tip insulators, do the following:



WARNING!

Burn hazard – risk of serious injury. To avoid serious burns, wear personal protective equipment consisting of a heat-resistant coat, heat-resistant gloves, and a full face shield over safety glasses. Use adequate ventilation for fumes.

1. Separate the cavity plate from the hot runner. Refer to [Section 6.14](#) for more information.

NOTE:

Some nozzle tip insulators may remain in the gate detail in the cavity plate.

2. Lock out and tag the machine. For machine lockout and tag procedures refer to the machine documentation.



IMPORTANT!

Due to geometric variations between the gate details and the witness marks left in the nozzle tip insulators by the nozzle tips, Husky does not recommend reusing nozzle tip insulators. Previously used nozzle tip insulators should always be replaced with new nozzle tip insulators. If reuse is absolutely necessary (i.e. unscheduled maintenance with no spares on hand), order new nozzle tip insulators and replace as soon as possible. Contact your nearest Husky Regional Service and Sales Office or www.husky.co.



IMPORTANT!

Nozzle tip insulators form to the dimensions of the nozzle tip and gate detail when compressed. Before removing a nozzle tip, make sure to record the nozzle tip location and the orientation of the nozzle tip insulator. This will help avoid resin leakage if the nozzle tip insulators are reused.

3. If nozzle tips must be reused, record the position and orientation of each nozzle tip insulator.

CAUTION!

Mechanical hazard – risk of equipment damage. Do not allow molten resin to drop on nozzle tip insulators while the insulators are being removed. The additional material will increase the calculated preload for the nozzle tip insulator and damage the hot runner during assembly with the cavity plate.

Make sure all nozzle tip insulators are clean during removal and installation.

4. Remove the nozzle tip insulators from the nozzle tips using needle nose pliers. Be careful not to damage the nozzle tips or sealing surfaces.
5. If a nozzle tip insulator is found in the gate detail in the cavity plate, remove the nozzle tip insulator using a 10 mm or 3/8"-18 NPT tap or pipe and then clean the gate.

Clean the gate detail using a pointed hardwood stick and soft cloth, or a Scotch-Brite No. 7447 (Maroon). Care must be taken not to scratch the cylindrical sealing surfaces between the gate insert and nozzle housing. Even a slight scratch may cause leaks at high injection pressures.

6. Inspect the nozzle tip insulators for resin. If resin is found, the nozzle tip insulator is leaking and will not function as required.

Determine the following:

- The cause of the leak by inspecting the gate insert dimensions.
- The nozzle tip position to make sure it is correct before a new insulator is installed.

7. Remove all locks and tags.

6.19.2 Installing Nozzle Tip Insulators

To install nozzle tip insulators, do the following:

**IMPORTANT!**

Due to geometric variations between the gate details and the witness marks left in the nozzle tip insulators by the nozzle tips, Husky does not recommend reusing nozzle tip insulators. Previously used nozzle tip insulators should always be replaced with new nozzle tip insulators. If reuse is absolutely necessary (For example, unscheduled maintenance with no spares on hand), order new nozzle tip insulators and replace as soon as possible. Contact your nearest Husky Regional Service and Sales Office or www.husky.co.

CAUTION!

Mechanical hazard – risk of damage to the hot runner. Make sure all nozzle tip insulators are clean before they are installed. Any additional material on the nozzle tip insulator will increase the calculated preload and damage the hot runner during assembly with the cavity plate.

1. Make sure the hot runner is either installed in the machine or laying on a work bench with the nozzle tips facing up.
2. Make sure all nozzle tip insulators are clean and in good condition.

CAUTION!

Mechanical hazard – risk of damage to the hot runner. Due to geometric variations between the gate details and the witness marks left in nozzle tip insulators by the nozzle tips, Husky does not recommend reusing nozzle tip insulators. Previously used nozzle tip insulators should always be replaced with new nozzle tip insulators whenever possible.

3. Place a nozzle tip insulator on each nozzle tip. If used nozzle tip insulators are being installed, make sure they are installed on the same nozzle tip as previously removed and in the same orientation.



Figure 6-53: Nozzle Tip Insulator

4. Install the cavity plate. Refer to [Section 6.14](#) for more information.

Chapter 7 Storage and Shipping

Hot runner surfaces are sensitive to many environmental conditions and require special methods for storage and shipping to avoid damage.

NOTE:

The storage instructions in [Section 7.2](#) are recommended when shipping the hot runner by air.

NOTE:

The storage instructions in [Section 7.3](#) are recommended when shipping the hot runner overseas.

CAUTION!

Mechanical hazard – risk of damage to the hot runner. Store all hot runners in an air conditioned environment.

7.1 Corrosion Protection

Humidity, salt in the air, rapid weather changes, and even condensation that forms during operation can quickly damage an unprotected hot runner.

Use a protective spray that does not contain chlorofluorocarbons (CFCs), has good moisture and oxidation resistance, and is resistant to mild acids and alkaline.

For additional corrosion protection during storage, add a moisture-absorbing silicate bag before sealing the hot runner in a vacuum polyethylene bag.

**WARNING!**

Poison hazard – risk of death or serious injury. Before using any corrosion protection product, always follow the supplier's recommendations for use and thoroughly review the Material Safety Data Sheet (MSDS).

7.2 Short Term Storage

Short term storage is intended for periods less than three months and can be done either in the machine or separately.

7.2.1 Storing in the Machine

1. Open the clamp to full shutheight.
2. Lock out and tag the machine and controller (if equipped). Refer to [Section 2.5](#) for more information.
3. Clean the mold, hot runner and molding surfaces of dirt, debris and condensation.
4. Perform all required preventive maintenance procedures. Refer to [Section 6.1](#) for more information.
5. Inspect all moving components for damage. Replace or repair as needed.



WARNING!

Poison hazard – risk of death or serious injury. Protective sprays can cause headaches, dizziness, nausea and anesthetic effects. Wear a face shield and solvent resistant gloves. If used in an enclosed area, use an organic vapor respirator or self-contained breathing apparatus.

6. Spray all accessible faces and molding surfaces with a protective spray. Allow surfaces to dry for approximately two hours. Refer to [Section 3.9](#) for information about recommended lubricants.

If additional coats are required, make sure the hot runner has thoroughly dried before the next application.

7. Leave the mold open.

7.2.2 Storing Outside the Machine

To store the hot runner separately from the machine for a period of less than three months, do the following:

1. Open the clamp to full shutheight.
2. Lock out and tag the machine and controller (if equipped). Refer to [Section 2.5](#) for more information.
3. Purge all cooling water from the hot runner. Refer to the machine manufacturer's documentation for more information.
4. Clean the mold, hot runner and molding surfaces of dirt, debris and condensation.
5. Perform all required preventive maintenance procedures as required. Refer to [Section 6.1](#) for more information.
6. Inspect all moving components for damage. Replace or repair as needed.



WARNING!

Poison hazard – risk of death or serious injury. Protective sprays can cause headaches, dizziness, nausea and anesthetic effects. Wear a face shield and solvent resistant gloves. If used in an enclosed area, use an organic vapor respirator or self-contained breathing apparatus.

7. Spray all accessible faces and molding surfaces with LPS 2 protective spray. Allow surfaces to dry for approximately two hours. Refer to [Section 3.10](#) for specifications on protective spray.
If additional coats are required, make sure the hot runner has thoroughly dried before the next application.
8. Remove the hot runner from the machine. Refer to [Removing the Manifold assembly from the Mold](#) for more information
9. Place a cover over the hot runner to protect it during storage.
10. Store the hot runner in an air conditioned environment.

7.3 Long Term Storage

To store the mold and/or hot runner for a period of more than three months, do the following:

NOTE:

The following procedure can also be used to store spare parts.

1. Prepare the mold and/or hot runner for storage and remove it from the machine. Refer to [Section 7.2.2](#) for more information.
2. Place the mold and/or hot runner on a wooden platform.
3. Place the mold and/or hot runner in a 0.1 mm (0.004 in) or heavier (thicker) polyethylene bag along with a suitably sized moisture absorbing silicate bag.
The silicate bag offers additional corrosion protection.
4. Remove the lift bar and hoist ring.
5. Vacuum heat seal the polyethylene bag to retain the protective spray and prevent invasion of dirt or moisture.

7.4 Shipping the Hot Runner

The following guidelines should be followed when shipping a hot runner:

CAUTION!

Mechanical hazard – risk of damage to equipment. Residual coolant could freeze when transporting the hot runner in cold climates. Make sure all coolant is drained fully from the system before transporting it. Failure to do so could cause severe damage to the hot runner.

1. Before shipping the hot runner, check that all coolant has been drained fully.
2. Pack the hot runner, regardless of where it is being shipped, in a shipping crate. This will provide the best possible protection from any damage. For Cross Manifold design, and prior

to manifold removal, make sure that the alignment pull dowels that keep the cross and main manifolds aligned during assembly are re-installed.

- 3.** When returning a mold and/or hot runner to Husky for refurbishing, include the following items for testing purposes:
 - All electrical cables and switch boxes
 - All lift bars and latch bars installed in their shipping position on the hot runner
 - All mechanisms that had to be removed from the hot runner for any reason