

Ultra Valve Gate Hot Runner

Hot Runner Service Manual

Issue: v 2.3 — March 2022

Document No.: 5275156

This product manual is intended to provide information for safe operation and/or maintenance. Husky reserves the right to make changes to products in an effort to continually improve the product features and/or performance. These changes may result in different and/or additional safety measures that are communicated to customers through bulletins as changes occur.

This document contains information which is the exclusive property of Husky Injection Molding Systems Limited. Except for any rights expressly granted by contract, no further publication or commercial use may be made of this document, in whole or in part, without the prior written permission of Husky Injection Molding Systems Limited.

Notwithstanding the foregoing, Husky Injection Molding Systems Limited grants permission to its customers to reproduce this document for limited internal use only.

Husky[®] product or service names or logos referenced in these materials are trademarks of Husky Injection Molding Systems Ltd. and may be used by certain of its affiliated companies under license.

All third-party trademarks are the property of the respective third-party and may be protected by applicable copyright, trademark or other intellectual property laws and treaties. Each such third-party expressly reserves all rights into such intellectual property.

©2010 – 2022 Husky Injection Molding Systems Ltd. All rights reserved.

General Information

Telephone Support Numbers

North America	Toll free	1-800-465-HUSKY (4875)
Europe	EC (most countries)	008000 800 4300
	Direct and Non-EC	+ (352) 52115-4300
Asia	Toll Free	800-820-1667
	Direct:	+86-21-3849-4520
Latin America	Brazil	+55-11-4589-7200
	Mexico	+52-5550891160 option 5

For on-site service, contact your nearest Husky Regional Service and Sales office.

For non-emergency questions and issues you may also e-mail Husky at techsupport@husky.ca.

Husky Regional Service and Sales Offices

For the location closest to you, please visit www.husky.co.

Product Upgrades

Upgrades are available that can improve your output, reduce cycle times, and add functionality to your Husky equipment.

To see what upgrades are available for your Husky equipment, visit our website at www.husky.co or call your nearest Husky Regional Service and Sales Office.

Ordering Spare Parts

All spare parts for Husky equipment can be ordered through your nearest Husky Parts Distribution Center or online at www.husky.co.

Hot Runner Refurbishing

Husky offers services for repairing, modifying, and retrofitting Husky hot runners. Contact your Husky Regional Service and Sales office for details.

Table of Contents

General Information.....	iii
Telephone Support Numbers.....	iii
Husky Regional Service and Sales Offices.....	iii
Product Upgrades.....	iii
Ordering Spare Parts.....	iii
Hot Runner Refurbishing.....	iv
Chapter 1: Introduction.....	11
1.1 Purpose of the Equipment.....	11
1.2 Restrictions of Use.....	11
1.3 Unauthorized Modifications.....	11
1.4 Auxiliary Equipment.....	11
1.5 Documentation.....	12
1.5.1 Manuals.....	12
1.5.2 Engineering Drawings and Schematics.....	13
1.5.3 Safety Alert Conventions.....	13
1.6 Training.....	14
1.7 Nameplates.....	14
1.7.1 Hot Runner Nameplate.....	14
1.8 Special Tools.....	16
1.8.1 Nozzle Tip Sockets and Heater Removal Tools.....	16
1.8.2 Valve Stem Removal Tools.....	17
1.8.3 Backup Pad Removal Tools.....	17
1.8.4 Alignment Bushing Installation Tool.....	17
1.8.5 Front Ring Removal Tools.....	18
1.8.6 Double Delta Seal Installation Tools.....	18
1.8.7 Retaining Clip Installation Tool.....	18
1.8.8 Standard Nozzle Tip Sockets.....	18
1.8.9 Thermocouple Wire Stripping Tools.....	19
1.8.10 Single Probe Thermocouple Removal Tools.....	20
1.8.11 Crimping Tools for Contact Pins (25 or 64 Pin Connectors).....	20
Chapter 2: Safety Summary.....	21
2.1 Qualified Personnel.....	21
2.2 Safety Guidelines.....	21
2.3 Safety Hazards.....	21
2.3.1 Mechanical Hazards.....	22
2.3.2 Burn Hazards.....	22
2.3.3 High Pressure Hazards.....	23
2.3.4 Electrical Hazards.....	24
2.3.5 Gas, Vapor and Dust Emissions.....	24
2.3.6 Slip, Trip or Fall Hazards.....	24
2.3.7 Lifting Hazards.....	24

2.4	Safety Signs.....	24
2.5	Lockout and Tagout.....	26
2.6	Personal Protective Equipment and Safety Equipment.....	27
2.6.1	Personal Protective Equipment (PPE).....	27
2.6.2	Safety Equipment.....	28
2.7	Material Safety Data Sheet (MSDS).....	29
2.8	Materials, Parts and Processing.....	29
2.9	Safety Latch Bars.....	29
2.10	Lift Bars and Swivel Hoist Rings.....	30
Chapter 3: Specifications.....		31
3.1	Weight.....	31
3.2	Operating Temperature.....	31
3.3	Electrical System Specifications.....	31
3.3.1	Controller Requirements.....	31
3.3.2	Nozzle Heaters.....	32
3.3.3	Manifold Heaters.....	32
3.3.3.1	Spare Thermocouple Wires.....	32
3.3.4	Power Fluctuation.....	33
3.4	Pneumatic Specifications.....	33
3.5	Recommended Lubricants.....	34
3.6	Rust Inhibitor Specifications.....	35
3.7	Torque Specifications.....	36
Chapter 4: Installation and Removal.....		37
4.1	Lifting and Handling.....	37
4.1.1	Lifting and Handling Using a Single Lifting Point.....	38
4.1.1.1	Laying Down Plates Using a Single Lifting Point.....	38
4.1.1.2	Picking Up Plates Using a Single Lifting Point.....	39
4.1.2	Lifting and Handling Using Multiple Lifting Points.....	40
4.1.3	Lifting Using a Lift Bar.....	41
4.1.4	Lifting Using Swivel Hoist Rings.....	42
4.2	Mounting Methods.....	43
4.2.1	Direct Bolting.....	43
4.2.2	Clamping.....	44
4.2.3	Quick Mold Changers and Clamping Systems.....	45
4.3	Removing and Installing the Hot Runner.....	45
4.3.1	Installing the Hot Runner.....	45
4.3.2	Removing the Hot Runner.....	47
Chapter 5: Startup and Operation.....		51
5.1	Preparing the Hot Runner.....	51
5.2	Heating Up the Hot Runner, Mold and Machine.....	52
5.3	Precharging the Hot Runner.....	53
5.4	Producing Test Parts.....	54
Chapter 6: Maintenance.....		57

6.1	Scheduled and Non-Scheduled Maintenance.....	57
6.1.1	Preventive Maintenance.....	58
6.1.2	Service Procedures.....	58
6.2	Changing the Resin Color.....	59
6.3	Extending Nozzle and Sprue Heater Wire Leads.....	60
6.4	Measuring Preload.....	61
6.4.1	Measuring Preload for Manifolds in VG-LX and EX Systems.....	62
6.4.2	Measuring Preload for Manifolds in VG-SX Systems.....	62
6.4.3	Measuring Preload for Cross Manifolds in Two Plate Systems (If Equipped).....	64
6.4.4	Measuring Preload for Cross Manifolds in Three Plate Systems (If Equipped).....	65
6.5	Testing Heaters.....	67
6.6	Removing and Installing the Cavity Plate.....	67
6.6.1	Removing the Cavity Plate On a Work Bench.....	68
6.6.2	Installing the Cavity Plate On a Work Bench.....	69
6.6.3	Removing the Cavity Plate In the Machine.....	71
6.6.4	Installing the Cavity Plate In the Machine.....	73
6.7	Removing and Installing the Backing Plate.....	74
6.7.1	Removing the Backing Plate.....	75
6.7.2	Installing the Backing Plate.....	77
6.8	Removing and Installing the Center Plate (If Equipped).....	79
6.8.1	Removing the Center Plate (If Equipped).....	79
6.8.2	Installing the Center Plate (If Equipped).....	81
6.9	Removing and Installing Manifolds.....	83
6.9.1	Removing a Cross Manifold (If Equipped).....	83
6.9.2	Removing a Manifold.....	84
6.9.3	Inspecting and Cleaning Manifolds.....	86
6.9.4	Installing a Manifold.....	87
6.9.5	Installing a Cross Manifold (If Equipped).....	90
6.10	Removing and Installing VG-LX and EX Backup Pads.....	91
6.10.1	Removing the VG-LX and EX Backup Pads.....	91
6.10.2	Installing the VG-LX and EX Backup Pads.....	92
6.11	Removing and Installing VG-SX Cylinders.....	93
6.11.1	Removing Cylinders.....	93
6.11.2	Installing Cylinders.....	94
6.12	Removing and Installing Valve Stems.....	95
6.12.1	Removing the Valve Stems for U350 and U500 VG-SX Systems.....	96
6.12.2	Installing the Valve Stems for U350 and U500 VG-SX Systems.....	100
6.12.3	Removing the Valve Stems for U500 and U750 VG-LX and EX Systems.....	105
6.12.4	Installing the Valve Stems for U500 and U750 VG-LX and EX Systems.....	109
6.12.5	Removing the Valve Stems for U1000 VG-LX Systems.....	111
6.12.6	Installing the Valve Stems for U1000 VG-LX Systems.....	116
6.13	Replacing the Double Delta Seals.....	118
6.14	Removing and Installing Nozzle Tips.....	119
6.14.1	Removing the Nozzle Tips when Hot.....	120
6.14.2	Removing the Nozzle Tips when Cold.....	122
6.14.3	Removing U750 Nozzle Tips with U1000 VG-EXX RGA Nozzles.....	124
6.14.4	Installing the Nozzle Tips.....	125
6.14.5	Installing U750 Nozzle Tips with U1000 VG-EXX RGA Nozzles.....	127
6.14.6	Troubleshooting Nozzle Tip Heights.....	128

6.15	Refurbishing Ultra Flow VG Nozzle Tips.....	129
6.16	Removing and Installing Nozzle Housings.....	129
6.16.1	Removing VG-LX and EX and SX Nozzle Housings.....	130
6.16.2	Installing VG-LX and EX and SX Nozzle Housings.....	130
6.16.3	Removing VG-HP and VX-HP Nozzle Housings.....	131
6.16.4	Installing VG-HP and VX-HP Nozzle Housings.....	132
6.16.5	Inspecting and Cleaning Nozzle Housings.....	133
6.17	Removing and Installing Nozzle Heaters.....	134
6.17.1	Removing and Installing HTM Nozzle Heaters for U350, U500 and U750 Systems.....	134
6.17.1.1	Removing HTM Nozzle Heaters for U350, U500 and U750 Systems.....	134
6.17.1.2	Installing HTM Nozzle Heaters for U350, U500 and U750 Systems.....	135
6.17.2	Removing and Installing HTM Nozzle Heaters for U1000 Systems.....	137
6.17.2.1	Removing HTM Nozzle Heaters for U1000 Systems.....	137
6.17.2.2	Installing HTM Nozzle Heaters for U1000 Systems.....	137
6.17.3	Removing and Installing Copper Nozzle Heaters.....	139
6.17.3.1	Removing Copper Nozzle Heaters.....	139
6.17.3.2	Installing Copper Nozzle Heaters.....	140
6.17.4	Removing and Installing Ultra Nozzle Heaters With Front Rings (UNH 500 and 750).....	141
6.17.4.1	Removing Ultra Nozzle Heaters (UNH) With Front Rings.....	141
6.17.4.2	Installing Ultra Nozzle Heaters (UNH) with Front Rings.....	142
6.17.5	Removing and Installing Ultra Nozzle Heaters (UNH) With Ring Thermocouples.....	144
6.17.5.1	Removing Ultra Nozzle Heaters (UNH) With Ring Thermocouples.....	144
6.17.5.2	Installing Ultra Nozzle Heaters (UNH) With Ring Thermocouples.....	145
6.17.6	Removing and Installing Bi-Metal Nozzle Heaters.....	150
6.17.6.1	Removing Bi-Metal Nozzle Heaters.....	150
6.17.6.2	Installing Bi-Metal Nozzle Heaters.....	150
6.17.7	Removing and Installing VG-HP Nozzle Heaters.....	151
6.17.7.1	Removing VG-HP Nozzle Heaters.....	152
6.17.7.2	Installing VG-HP Nozzle Heaters.....	152
6.18	Removing and Installing Nozzle Tip Insulators (If Equipped).....	154
6.18.1	Removing the Nozzle Tip Insulators.....	154
6.18.2	Installing the Nozzle Tip Insulators.....	155
6.19	Removing Insulating Gate Bubbles (If Equipped).....	156
6.20	Removing and Installing Manifold Bushings.....	160
6.20.1	Removing and Installing Press Fit Manifold Bushings.....	160
6.20.2	Removing Slip Fit Manifold Bushings.....	160
6.20.3	Installing Slip Fit Manifold Bushings.....	161
6.21	Removing and Installing the Sprue Heater (If Equipped).....	162
6.21.1	Removing a Sprue Heater with a Built-In Thermocouple.....	162
6.21.2	Removing a Sprue Heater with a Separate Thermocouple.....	163
6.21.3	Installing a Sprue Heater with a Built-In Thermocouple.....	163
6.21.4	Installing a Sprue Heater with a Separate Thermocouple.....	164
6.22	Removing and Installing the Sprue Bushing.....	166
6.22.1	Removing the Sprue Bushing.....	166
6.22.2	Installing the Sprue Bushing.....	166
6.23	Removing and Installing Transfer Bushings (If Equipped).....	168
6.23.1	Removing Transfer Bushings (If Equipped).....	168
6.23.2	Installing Transfer Bushings (If Equipped).....	169
6.24	Adjusting the Thermocouple Wire Length.....	171

6.25	Removing Air and Water Plugs.....	172
6.26	Removing Resin from the Hot Runner	174
6.26.1	Plate Cleaning and Inspection.....	174
6.26.2	Cleaning Using a Fluidized Bed Process.....	176
6.26.2.1	Assistance.....	176
6.26.2.2	Disassembling the Hot Runner for Fluidized Bed Cleaning.....	176
6.26.2.3	Removing the PEEK Bushings.....	178
6.27	Removing Resin from the Manifold Plate.....	179
Chapter 7: Storage and Shipping.....		181
7.1	Corrosion Protection.....	181
7.2	Short Term Storage.....	181
7.2.1	Storing in the Machine.....	182
7.2.2	Storing Outside the Machine.....	182
7.3	Long Term Storage.....	183
7.4	Shipping the Hot Runner.....	183

Chapter 1 Introduction

This chapter describes the hot runner, training opportunities, and the available equipment manuals.

1.1 Purpose of the Equipment

Husky equipment and systems are designed for injection molding applications only, using approved materials and operating within design guidelines.

Contact your nearest Husky Regional Service and Sales office if you plan to use a Husky product for anything other than its intended use.

1.2 Restrictions of Use

Husky injection molding equipment must never be:

- operated by more than one person
- used for any purpose other than that described in [Section 1.1](#), unless otherwise approved by Husky
- used to extrude any materials not outlined in the scope of the harmonized EN201 or ANSI B151.1 standard
- operated or serviced by personnel unfamiliar with the inherent risks and necessary precautions related to injection molding equipment
- operated at temperatures higher than the maximum permissible temperature for the resin

1.3 Unauthorized Modifications

Unauthorized modifications or reconstruction of any Husky injection molding system is strictly prohibited. Modifications can be unsafe and/or void warranty.

Contact your nearest Husky Regional Service and Sales office to discuss modifications or requirements for Husky systems.

1.4 Auxiliary Equipment

Husky is only responsible for the interaction of Husky equipment and systems with auxiliary equipment when Husky is the system integrator. If auxiliary equipment is removed, the user must install proper safeguards to prevent access to the hazards.

For information about integrating non-Husky auxiliary equipment, contact your nearest Husky Regional Service and Sales office.

1.5 Documentation

A full set of manuals, drawings, schematics, certificates and other documentation are available for every Husky hot runner.

The following describes the documentation provided with each system, along with common conventions all readers should be familiar with.



IMPORTANT!

Keep all manuals in a convenient location for future reference.

1.5.1 Manuals

Husky manuals aid in the safe and proper use of Husky products. Where applicable, the manuals provide instructions on installation, operation and maintenance.

Personnel should thoroughly review all manuals provided with their Husky equipment prior to performing any tasks. Proceed with tasks only if all instructions are understood and always follow applicable workplace safety requirements.



IMPORTANT!

Images in the manuals are for reference only and may not represent specific equipment details. Refer to engineering drawings and schematics for specific details.

The following manuals are available for each hot runner system:

Operator Manual	Describes the basic startup, operation, shut down and daily maintenance of the hot runner
Service Manual	Describes the installation, startup, operation, shut down and maintenance the hot runner NOTE: Refer to the hot runner <i>Service Manual</i> for product specific instructions.

These manuals are available online through www.husky.co.

**IMPORTANT!**

Some manuals may contain addendums that detail new or updated information. Before reading a manual, make sure to review all available addendums located at the end of the manual.

1.5.2 Engineering Drawings and Schematics

Each Husky hot runner is provided with a set of drawings and schematics specific to the hot runner. These are used for troubleshooting the hot runner and ordering spare parts.

NOTE:

Each drawing and schematic is specific to the hot runner it is provided with.

1.5.3 Safety Alert Conventions

Safety alerts highlight hazardous conditions that may arise during installation, operation or maintenance and describe methods for avoiding personal injury and/or property damage.

Depending on the severity of the hazard, safety alerts start with one of the following signal words: Danger, Warning or Caution.

**DANGER!**

The DANGER safety alert indicates an imminently hazardous situation that, if not avoided, will result in death or serious injury.

**WARNING!**

The WARNING safety alert indicates a potentially hazardous situation that, if not avoided, could result in death or serious injury.

CAUTION!

The CAUTION safety alert indicates a potentially hazardous situation that, if not avoided, could result in property damage.

Other non-safety related alert types used in the manuals highlight important information needed by the user to install, operate or maintain the equipment properly. They may also, in some cases, describe best practices, offer an expanded explanation, or reference a related section in the manual.

Non-safety related alerts start with one of the following signal words: Note or Important.

NOTE:

The NOTE alert is used to add information to a subject that does not fit within the general flow of the document.

**IMPORTANT!**

The IMPORTANT alert is used to highlight important steps, conditions, or considerations related to the subject.

1.6 Training

All designated operators and maintenance personnel must be fully trained before using or servicing Husky injection molding systems.

If training is required, visit www.husky.co or contact your nearest Husky Regional Service and Sales office to learn more about Husky's training solutions.

**IMPORTANT!**

It is the obligation of the employer to properly train and instruct all personnel in the safe methods of operation and maintenance. Manuals and other reference material, which have been prepared by Husky for the operation and maintenance of Husky equipment, do not in any way absolve the employer from fulfilling these obligations and Husky disclaims liability for injury to personnel which is attributable to the employer's failure to do so.

1.7 Nameplates

Nameplates are affixed to the operator's side of the mold and hot runner for quick identification of the equipment type, source and general specifications.

**IMPORTANT!**

The mold and hot runner nameplates must never be removed. The information on the nameplates is necessary for mold selection, setup, parts ordering and troubleshooting.

Immediately order a new nameplate for the mold or hot runner if it is missing or damaged.

1.7.1 Hot Runner Nameplate

Every hot runner nameplate lists the following information:

- the location where the hot runner was manufactured
- the project number
- the material type allowed to be used in the hot runner
- the melt and mold temperatures
- electrical requirements and specifications

NOTE:

Other details and specifications may be required.

**IMPORTANT!**

Each hot runner is designed to process a specific type and grade of resin/filler based on the customer's requirements. Use of any other type or grade of resin/filler could affect part quality and/or the performance of the hot runner. Before using a different type or grade of resin/filler, contact Husky.

CAUTION!

Mechanical hazard – risk of damage to the hot runner. Never operate the hot runner outside of the melt and mold temperatures indicated on the nameplate. Internal resin leakage or component damage could occur.

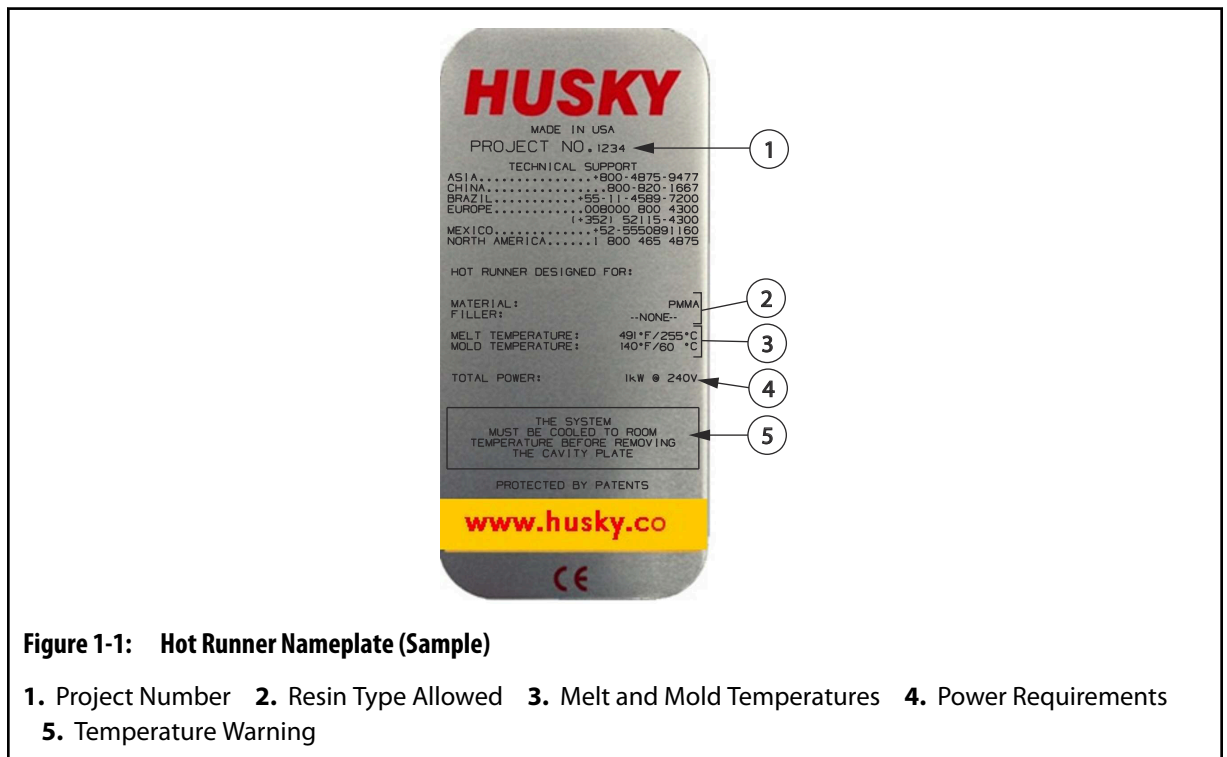

1.8 Special Tools

The following sections list various component-specific tools developed by Husky for use during maintenance of hot runner systems. Contact Husky to order special tools applicable to your hot runner system.

1.8.1 Nozzle Tip Sockets and Heater Removal Tools

Nozzle	Tip	Part Number		
		Nozzle Tip Socket	Heater Removal Tool	
U350	All	3872686 8 mm (0.25 in) 12 points	3163811 (Hex Key) OR 7287617 (Torque Wrench Assembly), 0.45 N·m (4 lbf·ft) OR 4715152 (Hex Driver)	3734732 Large Pitch >28 mm (1.1 in) OR 6599345 Small Pitch ≤28 mm (1.1 in)
U500	VG	2338059 12 mm (0.47 in) 6 points	2341532 (Bi-Metal and UNH with Front Ring) 3163811 (HTM Heater) Hex Key 4715152 (HTM Heater) Hex Driver 7307376 (UNH with Ring Thermocouple) 7287617 (HTM Heater) Torque Wrench Assembly, 0.45 N·m (4 lbf·ft)	
		531983 11 mm (0.43 in) 12 points		
	VG-X	3436695		
	VG-XX			
	VX	3253169		
U750	VG-R	531983	3163811 (HTM Heater) Hex Key 4715152 (HTM Heater) Hex Driver 535160 (Bi-Metal and UNH with Front Ring) 7298786 (UNH with Ring Thermocouple) 7287617 (HTM Heater) Torque Wrench Assembly, 0.45 N·m (4 lbf·ft)	
	VG	2338059		
	VX	3253170		
	VG-EXX RGA	22 mm (0.87 in) socket to remove nozzle tip adapter		

Nozzle	Tip	Part Number	
		Nozzle Tip Socket	Heater Removal Tool
U750-UP	Ultra Packaging (UP)	3722920	3756216
U1000	VG	2449784	2410903 (Bi-Metal)
	VX	2816672	

1.8.2 Valve Stem Removal Tools

Description	Part Number
VG-LX	4793599
VG-EX	4793600
VG-SX	4793598
VG-PX	9142633

1.8.3 Backup Pad Removal Tools

Description	Part Number
U350	2603927
U500	
U750	
U1000	2948588

1.8.4 Alignment Bushing Installation Tool

Description	Part Number
For 25mm ID Plate Alignment Bushings	7568206

1.8.5 Front Ring Removal Tools

Description	Part Number
U500	3634736
U750	4925394

1.8.6 Double Delta Seal Installation Tools

Description	Part Number
U350 VG-SX	3446999
U500 VG-SX	
U350 VG-LX	3087823
U500 VG-LX	
U750 VG-LX	
U500 VG-EX	3446982
U750 VG-EX	
U1000 VG-LX	3500798

1.8.7 Retaining Clip Installation Tool

Description	Part Number
U350	4405801

1.8.8 Standard Nozzle Tip Sockets

Size	Points	Drive	Part Number
4 mm	6 (Allen Key)	3/8 inch	622974
6 mm	6 (Allen Key)	3/8 inch	622972
6mm	6	3/8 inch	533942
8 mm	6	1/4 inch	2996145

Size	Points	Drive	Part Number
8 mm	12	1/4 inch	3436695
8 mm	6	3/8 inch	1501813
10 mm	12	3/8 inch	3253169
11 mm	6	3/8 inch	3320712
11 mm	12	3/8 inch	531983
12 mm	6	3/8 inch	2338059
13 mm	6	3/8 inch	536678
14 mm	12	3/8 inch	533533
15 mm	6	3/8 inch	2449784
15 mm	12	3/8 inch	3253170
16 mm	6	3/8 inch	2402461
16 mm	12	3/8 inch	2816670
17 mm	6	3/8 inch	2308879
20 mm	6	1/2 inch	3722920
21 mm	12	1/2 inch	3274535
22 mm	6	1/2 inch	3311845
22 mm	12	1/2 inch	2816672
29 mm	6	1/2 inch	1502743
30 mm	6	1/2 inch	535571
1/2 inch	6	3/8 inch	2192309

1.8.9 Thermocouple Wire Stripping Tools

Description	Part Number
Strippers for thermocouple wires	4240042

1.8.10 Single Probe Thermocouple Removal Tools

Description	Part Number
11 mm Split Socket	4395427

1.8.11 Crimping Tools for Contact Pins (25 or 64 Pin Connectors)

Description		Part Number
Crimp Tool		2292562
Locator		2292574
Removal Tool		534645
Crimp Dies	0.5 to 1.5 mm ² (20 to 16 AWG) ^[1]	238569
	4.0 to 10 mm ² (12 to 8 AWG) ^[1]	2292575
	0.14 to 4.0 mm ² (26 to 12 AWG) ^[2]	2292576
	0.14 to 0.5 mm ² (26 to 20 AWG) ^[1]	2748316
	1.5 to 2.5 mm ² (16 to 14 AWG) ^[1]	2748326

^[1] Stamped crimp pins.
^[2] Machined crimp pins.

Chapter 2 Safety Summary

This chapter describes the general requirements and conditions for safe installation, operation and maintenance of the mold and hot runner.

**IMPORTANT!**

Personnel must read, understand and follow all safety precautions.

**IMPORTANT!**

Personnel must follow applicable industry and regulatory safety requirements for safe installation, operation and maintenance of equipment.

2.1 Qualified Personnel

Only fully trained and qualified personnel should be permitted to maintain equipment. Qualified personnel must have demonstrated skills and knowledge related to the construction, installation and operation of the injection molding equipment and have received safety training on the hazards involved.

2.2 Safety Guidelines

Personnel operating, installing, maintaining or servicing Husky equipment must adhere to safe working practices that are in compliance with the following guidelines:

- Lockout and tag electrical, pneumatic and hydraulic energy sources before servicing the mold/hot runner or entering the mold area
- Do not operate the mold/hot runner if scheduled preventive maintenance has not been performed
- Do not use a magnetic platen without approval from Husky and the magnetic platen supplier/manufacture
- Do not operate a hot runner outside the maximum melt and mold temperatures specified on the hot runner nameplate

2.3 Safety Hazards

Some common safety hazards associated with injection molding equipment are:

- Mechanical
- Electrical
- Burn
- High pressure (hydraulic system pressure and molten material spray)
- Slip, trip or fall
- Lifting
- Gas, vapor and dust emissions
- Noise

2.3.1 Mechanical Hazards

- **Worn Hoses and Safety Restraints**
Regularly inspect and replace all flexible hose assemblies and restraints.
- **Cooling Water Hoses**
Cooling water hoses degrade over time and need to be replaced on a yearly basis. Degraded hoses become brittle and can break or separate from the fitting when manipulated. To minimize the risk of failure, inspect the hoses regularly and replace as required.
Wait until the machine has cooled down before servicing cooling water hoses.
- **Seized Screws or Plugs**
If screws or plugs cannot be removed by normal methods using standard tooling and force, there is a high possibility these items have become seized; contact Husky for repair recommendation.



WARNING!

Mechanical and/or flying debris hazard - Tool breakage: risk projectile debris, serious injury and/or mechanical damage. Do not use excessive force and/or use tools beyond their designated limits. Do not use torque multiplying bars. Failure of tools may produce fragments that can become projectiles that may cause injury. For seized parts, consult Husky for safe disassembly instructions.

NOTE:

Manifold plugs are not a field repairable item and should never be removed. These items can only be serviced at a Husky manufacturing location.

2.3.2 Burn Hazards

- **Hot Surfaces**
The mold area, auxiliary mold equipment, and injection unit heating elements have numerous high temperature surfaces. At normal operating temperatures, contact with these surfaces will cause severe skin burns. These areas are clearly marked with safety signs. Wear personal protective equipment when working in these areas.

- **Molten Material**
Never touch process material purged or otherwise flowing from the nozzle, mold, hot runner or feed throat area. Molten material can appear cool on the surface, but remain very hot on the inside. Wear personal protective equipment when handling purged material.

2.3.3 High Pressure Hazards



WARNING!

Burn and hot resin spray hazard – risk of death, serious injury and/or damage to the hot runner. All nozzle and sprue heaters (if equipped) must be turned on when manifold heaters are turned on. Failure to do so could result in generation of dangerous pressure levels in the manifold, resulting in component failure and/or sudden release of hot resin.

Pressure inside the hot runner manifold(s) can increase to dangerous levels if the nozzle and sprue heaters (if equipped) are not turned on before or at the same time as the nozzle sprue.

The pressure is generated when the injection nozzle sprue is plugged with frozen resin and the residual resin in the manifold is heated. This pressure can release suddenly causing the resin plug to eject from the sprue and hot resin to spray from the nozzle tips. The risk of serious burn injuries as a result is increased.

Moisture that infiltrates and is trapped in the hot runner molten material can also increase the risks of this potential hazard. If the temperature of the water in the molten material becomes greater than 400 °C (725 °F), the pressure of this trapped water can be significant enough to rupture the metal housing and cause serious injury to personnel.

To avoid this hazard, do the following:

1. Always make sure all nozzle and sprue heaters (if equipped) are turned on any time manifold heaters are turned on outside of the mold. The nozzle and sprue heaters can be turned on independently of the manifold heaters, however, it is recommended that they be heated first or slaved to the manifold heaters so they heat up in unison.
2. Always make sure the nozzle tips are open and the nozzle housings are dry prior to applying heat to the manifold.



IMPORTANT!

In the event of water leaking onto or into the hot runner, the nozzle tips must be removed (cold) and the plastic in the nozzles drilled out to ensure they are open to atmosphere. This can be done using a standard twist drill with the cutting edges removed to prevent damage to the melt channel.

Replace the cavity plate prior to heating the system.

2.3.4 Electrical Hazards

- **Power Supply**
Molding equipment draws high amperage current at high voltage. The electrical power requirements are indicated on the nameplate and in the electrical schematics. Connect equipment to a suitable power supply as specified in the electrical schematics and in compliance with all applicable local regulations.
- **Water**
Water on the hot runner can be in close proximity to electrical connections and equipment. This can lead to a short circuit, resulting in serious electrical damage to the equipment. Always keep water lines, hoses, and hose fittings in good condition to avoid leaks.

2.3.5 Gas, Vapor and Dust Emissions

Certain processed materials release harmful gas, vapors or dust. Install an exhaust system according to local codes.

2.3.6 Slip, Trip or Fall Hazards

Do not walk, stand, climb or sit on machine surfaces not approved for safe access.

Do not step on the tie bar or any surfaces with grease and/or oil.

Use a safety approved platform, walkway and step ladders designated to access areas that are not accessible from the floor.

2.3.7 Lifting Hazards

When lifting equipment, use suitable lifting devices, proper balancing techniques and designated lifting points. Refer to the installation details, and to handling and lifting instructions. Do not exceed the rated capacity of the lifting equipment.

2.4 Safety Signs

















Safety signs clearly mark potentially hazardous areas in or around equipment. For the safety of personnel involved in equipment installation, operation and maintenance, use the following guidelines:









- Verify that all signs are in the proper locations. Refer to the drawing package for details.
- Do not alter signs.
- Keep signs clean and visible.
- Order replacement signs when necessary. Refer to the drawing package for part numbers.

The following safety symbols may appear on safety signs:

NOTE:

Safety signs may include a detailed explanation of the potential hazard and associated consequences.

Safety Symbol (ANSI)	Safety Symbol (ISO)	General Description of Symbol
		<p>General</p> <p>This symbol indicates a potential personal injury hazard. It is usually accompanied by another pictogram or text to describe the hazard.</p>
		<p>Hazardous Voltage</p> <p>This symbol indicates a potential electrical hazard that will cause death or serious injury.</p>
		<p>High Pressure Molten Material</p> <p>This symbol indicates the presence of a high pressure molten material hazard that could cause death or severe burns.</p>
		<p>Lockout/Tagout</p> <p>This symbol identifies an energy source (electrical, hydraulic or pneumatic) that must be de-energized before maintenance is performed.</p>
		<p>Crushing and/or Impact Points</p> <p>This symbol indicates a crushing and/or impact area that could cause serious crushing injury.</p>
		<p>High Pressure</p> <p>This symbol indicates a heated water, steam or gas hazard that could cause severe injury.</p>
		<p>High Pressure Accumulator</p> <p>This symbol indicates the sudden release of high pressure gas or oil could cause death or serious injury.</p>
		<p>Hot Surfaces</p> <p>This symbol identifies the presence of exposed hot surfaces that could cause serious burn injuries.</p>

Safety Symbol (ANSI)	Safety Symbol (ISO)	General Description of Symbol
		<p>Slip, Trip or Fall Hazard This symbol indicates a slip, trip or fall hazard that could cause injury.</p>
		<p>Do Not Step This symbol identifies a location that should not be used as a step because it may be a slip, trip or fall hazard and could cause injury.</p>
		<p>Crushing and/or Shearing Hazard This symbol indicates the presence of a crushing and/or shearing hazard at the rotating screw that could cause serious injury.</p>
		<p>Read Manual Before Operation This symbol indicates that qualified personnel should read and understand all instructions in the equipment manuals before working on the equipment.</p>
		<p>Class 2 Laser Beam This symbol indicates a laser beam hazard that could cause personal injury with prolonged exposure.</p>
		<p>Barrel Cover Grounding Strap This symbol indicates an electrical hazard related to the barrel cover grounding strap that could cause death or serious injury.</p>
		<p>Do Not Grease This symbol indicates greasing is not required under normal operating conditions. Greasing could cause equipment failure.</p>

2.5 Lockout and Tagout

A lockout/tagout procedure in accordance with local codes must be performed on the machine, controller and auxiliary equipment before any maintenance activities are performed while in the machine or connected to an external energy source.

**WARNING!**

Complete the Lockout/Tag out of all energy sources in accordance with applicable local codes before performing maintenance activities. Failure to do so could result in serious injury or death. Refer to the machine and associated equipment manufacturer's manual for instructions.

Only qualified personnel should be permitted to install and remove locks and tags.





Lockout and tagout includes: the isolation of energy; depletion of stored energy; and prevention of re-energization from all energy sources.



2.6 Personal Protective Equipment and Safety Equipment

Personal injury can be avoided when personnel wear appropriate protective gear and use special safety equipment. The following describes the safety gear and equipment that should be used when working with the machine and any auxiliary equipment.

2.6.1 Personal Protective Equipment (PPE)

Wear appropriate personal protective equipment when working on or near equipment. Standard personal protective equipment includes:

Item	Description
	<p>Safety Glasses For protecting the eyes from flying objects/particles, heat, sparks, splash from molten material, and more.</p>
	<p>Face Shield For protecting the entire face area from flying objects/particles, heat, sparks, splash from molten material, and more.</p>
	<p>Heat Resistant Gloves For protecting the hands from extreme heats.</p>
	<p>Hearing Protection For protecting the ears from loud ambient noise.</p>

Item	Description
	<p>Safety Shoes For protecting the feet from electrical shocks, crushing hazards, puncture hazards, splash from molten material, and more.</p>
	<p>Non-Melting Natural Fiber Pants and Long Sleeved Shirt For protecting the body from abrasions, cuts, and potential splash from molten material.</p>

2.6.2 Safety Equipment

Use appropriate safety equipment when working on or near equipment.

Standard safety equipment includes:

- **Exhaust Fan**
For collecting potentially harmful plastic fumes
- **Purging Container**
For containing hot resin purged from the injection unit
- **Vacuum Cleaner**
For collecting spilled resin pellets and other debris that may create a falling hazard
- **Stairs and Ladders**
For ensuring safe access to areas of the machine
- **Danger Signs**
For warning other personnel to stand clear of a component or area of the machine
- **Locks and Tags**
For preventing the use of specific systems and components
- **Fire Extinguishers**
For the expedient suppression of small fires
- **Telescopic Mirror**
For safely inspecting hot runner nozzle tips from outside the mold area
- **Brass Hammers and Brass Rods**
For safely removing dried resin deposits

2.7 Material Safety Data Sheet (MSDS)



WARNING!

Chemical hazard - Some of the chemicals used with Husky equipment are potentially hazardous and could cause injury and illness. Before storing, handling, or working with any chemical or hazardous material, thoroughly read and understand each applicable Material Safety Data Sheet (MSDS), use recommended personal protective equipment and follow the manufacturer's instructions.

The Material Safety Data Sheet (MSDS) is a technical document which indicates the potential health effects of a hazardous product. It contains safety guidelines to protect personnel, as well as information about use, storage, handling, and emergency procedures.

Always refer to the applicable Material Safety Data Sheet before doing the following:

- handling a chemical product
- disassembling any portion of Husky equipment that may result in exposure to a chemical product

Contact the material supplier to obtain a copy of the MSDS sheet.

2.8 Materials, Parts and Processing

To prevent personal injury or damage to the equipment, make sure of the following:

- The equipment is only used for its intended purpose, as described in the manuals
- The operating temperatures do not exceed the specified permissible maximum value for the resin
- The maximum temperature set point is set below the flash point of the material being processed
- Lubricants, oils, process materials and tools used on equipment meet Husky specifications
- Only authentic Husky parts are used

2.9 Safety Latch Bars

All mold and hot runner assemblies are delivered with safety latch bars installed on the operator and non-operator side of the assembly.

Safety latch bars are used to hold plates together for maintenance and installation purposes. They provide a safe means for transporting and handling the assembly, and for securing plates that are normally fastened together during normal operation.



WARNING!

Crushing hazard – risk of death or serious injury. Plates could separate from each other and fall during handling if not properly secured. Under no circumstances are multiple plates to be handled with only one safety latch bar installed.

Safety latch bars must always be installed in pairs on diagonally opposite sides of the mold and hot runner assembly to provide equal pull on the plates.

NOTE:

Specific instructions on how to install safety latch bars are provided when needed in this manual.

2.10 Lift Bars and Swivel Hoist Rings

Every mold and hot runner assembly is equipped with tapped lift holes for lifting either the complete assembly or individual plates. Husky only supplies special lifting equipment (including a lift bar and swivel hoist rings) when required. This lifting equipment is designed specifically for the mold/hot runner assembly. When Husky provides special lifting equipment, use only Husky specified and supplied lifting equipment.

NOTE:

Separate lift bars for the hot and cold halves of the mold and hot runner assembly may be provided based on the requirements of the assembly.



IMPORTANT!

Make sure all lifting equipment is rated for the load and in safe operating condition. Follow the recommendations and use care when moving or handling plates or assemblies.

For instructions about lifting plates and plate assemblies and using the Husky provided lift bar and swivel hoist rings, refer to [Section 4.1](#).

NOTE:

The Husky provided lift bar, swivel hoist rings and associated hardware must be stored together while the mold, hot runner, tooling plate and CoolPik plate are in operation.

Chapter 3 Specifications

This chapter outlines the necessary temperature, electrical, air and lubricant information needed to operate and maintain the hot runner.

3.1 Weight

The full weight of the hot runner assembly is listed on the assembly drawings.

3.2 Operating Temperature

The hot runner must operate within a specific temperature range to prevent internal resin leakage and damage to internal components as the result of thermal expansion. This temperature range is listed on the hot runner nameplate as the temperature difference between the manifold and the mold.



IMPORTANT!

The temperature range is critical for the hot runner system to be able to create a proper seal. It is important the designed operating temperature window be observed at all times.

For more information about the nameplate, refer to [Section 1.7.1](#).

3.3 Electrical System Specifications

Refer to the electrical schematic for the following information:

- Control zones
- Multi-pin connector and pin positions for each heater and thermocouple wire
- Connecting heater wiring in parallel (if applicable)
- Amperage, wattage and resistance of each heater
- Keypin locations

3.3.1 Controller Requirements

The number of control zones required for the heaters will depend on the size and requirements of the basic system.

**DANGER!**

Electrical hazard – risk of serious injury, fire and/or overload of electrical components. Do not use a controller with an amperage rating less than that required by the heaters. Do not use a controller with a higher amperage rating than the connectors or cables to the hot runner.

The type of controller can be either:

- Automatic control using a thermocouple to sense the nozzle tip temperature
- Manual control where the controller is set to provide power during a percentage of time

There may be an optional switchbox for turning ON or OFF the power to individual nozzle heaters.

NOTE:

The controller output to the heaters must be set to 220 to 240 V, 50 to 60 Hz single phase.

3.3.2 Nozzle Heaters

The nozzle heaters can be controlled separately or in zones by manual controllers. Refer to the electrical schematic for the correct configuration.

3.3.3 Manifold Heaters

Whenever possible, the manifold heaters are wired in parallel and controlled by a single controller zone. The circuit will be completed either at the cable connector or at the manifold.

The heaters are connected in multiple zones if the total amperage of all the heaters connected in parallel exceeds the capacity of a single controller zone.

Each zone is connected to a separate controller zone with its own thermocouple.

3.3.3.1 Spare Thermocouple Wires

The temperature of each manifold heater zone is sensed by a J-type thermocouple.

NOTE:

Special order thermocouples may be other types.

A spare thermocouple for each zone is also be routed to the base of the multi-pin connector to minimize down time. Should the main thermocouple fail, the spare can be easily connected without having to disassemble the mold. The failed thermocouple can be replaced at the next maintenance interval.

The spare thermocouples can also be used to verify the condition of the first thermocouple should a sensing problem develop.

NOTE:

To establish proper polarity when connecting thermocouples, follow the electrical schematic. For J-type thermocouples, the white wire is positive (+) and the red wire is negative (-). This wire color coding follows the ANSI J-Type North American Standard. The color coding and wire composition for J-type thermocouples in other parts of the world may be different and produce different readings.

3.3.4 Power Fluctuation

Hot runner systems are sensitive to fluctuations in power supply voltage. The nozzle and manifold heaters are rated for 240 V (or 200 V in special applications).

NOTE:

Always refer to the hot runner nameplate on the operator's side of the clamp before installing a hot runner. For more information on the nameplate, refer to [Section 1.7](#).

The manifold is always controlled by thermocouples and will compensate for minor voltage fluctuations.

Where the nozzle heaters are regulated by percentage timers, the heat output will be directly affected by voltage fluctuations. For example, a reduction of the voltage by only 10% will affect output (in Watts) by approximately 20%, which will reduce the nozzle temperatures considerably. Adjustment is required.

In severe cases where the stability of the power supply is known to be unreliable, it may be advisable to install an automatic voltage stabilizer rated for the power requirements of the controller.

3.4 Pneumatic Specifications

Pneumatic pressure is used to actuate the valve stems. Compressed air for the pneumatic system must meet the following requirements:

- The pressure dew points must be set to 11 °C (20 °F) below the lowest ambient temperature of the pneumatic system in order to keep compressed air clean and dry.
- Compressed air quality must meet the standards specified in DIN ISO 8573-1.
 - Solid particles - Class 1
 - Humidity - Class 4
 - Oil - Class 1
- Typical air pressure required is 5.52 to 8.27 bar (80 to 120 psi) , unless otherwise specified in the mold manufacturer's documentation.

NOTE:

For many pneumatic VG applications, air pressure of 7 bar (100 psi) may be sufficient, while some applications may require up to 12.5 bar (180 psi) for optimal and stable performance.

- Compressed air hoses must be large enough to permit adequate flow to the locations where air is required.
- Compressed air used for mold actuators must be interlocked with the machine operator’s gate, so opening the gate prevents any motion.
- Quick exhaust valves must be located close to the actuators they control, so the compressed air in the mold will decompress rapidly and speed operation of the actuator.
- Lockout valves must be installed (according to ANSI Z244.1 or local regulations) to the air supply for use when:
 - Serving the mold
 - Performing maintenance
 - Installing and removing the mold

3.5 Recommended Lubricants

The following are recommended lubricants to be used during the assembly and maintenance of Husky hot runners:

NOTE:

Husky recommends only the following lubricants and assumes no responsibility for lubricants not specified. It is the customers responsibility when consulting with an alternate supplier to make sure a suitable equivalent is used.

NOTE:

Lubricants of inferior quality can cause premature wear of components.



WARNING!

Chemical hazard - Some of the chemicals used with Husky equipment are potentially hazardous and could cause injury and illness. Before storing, handling, or working with any chemical or hazardous material, thoroughly read and understand each applicable Material Safety Data Sheet (MSDS), use recommended personal protective equipment and follow the manufacturer’s instructions.

CAUTION!

Contamination hazard – risk of contaminating lubricants or greases. Do not mix different brands or grades of lubricants or greases. Mixing lubricants or greases can cause premature breakdown of the lubricant or grease and could result in equipment damage.

**WARNING!**

Poison hazard – risk of death or serious injury. Some recommended lubricants may contain toxic and/or non-ingestible additives and may not be Food and Drug Administration (FDA) approved under the United States Department of Agriculture (USDA) rating H1 (formerly AA). Consult with the lubricant manufacturer for specific details.

Type/ Description	Trade Name	Part Number	Quantity	Used For
Static application Grease	Kem-A-Trix Fahrenheit 800 Bearing Gel	3936720	113 g (4 oz) Squeeze Tube	Guide pins, alignment dowels, screw heads and threads, O-ring seals ^[1]
		3936725	397 g (14 oz) Grease Gun Tube	
High temperature Anti-seize lubricant	Loctite Nickel Anti- Seize 771	5541918	225 g (8 oz) Can	Screws installed into the manifold
Protective spray	LPS 2 Lubricant	1501808	566 g (20 oz) Non- Aerosol Spray Bottle	Hot runner plates
Thread-locking fluid	Loctite 248	5541916	9 g (0.32 oz) Glue Stick	Screws that secure the manifold

^[1] Apply only as directed. Refer to maintenance procedures and/or assembly drawings for more information.

3.6 Rust Inhibitor Specifications

Any rust inhibitor used on the mold must meet the following specifications:

Type	Trade Name
Protective Spray	LPS 2 Protective Spray

3.7 Torque Specifications

Torque specifications are provided on the assembly drawings.

CAUTION!

Mechanical hazard – risk of damage to the hot runner. Use of improper torque can result in equipment damage. Always consult the assembly drawings for torque specifications.

Chapter 4 Installation and Removal

This chapter describes how to install and remove the hot runner assembly.



IMPORTANT!

The procedures contained in this chapter were written for a standard hot runner and do not take special options into consideration.

4.1 Lifting and Handling

The following procedures describe how to safely lift plates and plate assemblies.

CAUTION!

Mechanical hazard – risk of damage to the hot runner. Do not lift plates using magnetic lifting devices. These devices could potentially scratch a finely ground plate.



IMPORTANT!

Safety must be the primary consideration when lifting and moving a plate. Make sure to always use suitable lifting equipment that is inspected regularly and follow the recommendations outlined in this manual.



IMPORTANT!

Every mold and hot runner assembly is equipped with tapped lift holes for lifting either the complete assembly or individual plates. Husky only supplies special lifting equipment (including a lift bar and swivel hoist rings) when required. This lifting equipment is designed specifically for the mold/hot runner assembly. When Husky provides special lifting equipment, use only Husky specified and supplied lifting equipment. Use Husky special lifting equipment to lift only the designated mold or hot runner or component.



WARNING!

Crushing hazard – risk of death or serious injury. Inadequate lifting equipment could fail and cause death or serious injury. Use only Husky specified or supplied lifting equipment.



WARNING!

Crushing hazard – risk of death or serious injury. Misuse of lifting equipment could lead to equipment failure and cause death or serious injury. Use Husky only specified or supplied lifting equipment for lifting the assembly or the component for which the equipment has been designated by Husky.

4.1.1 Lifting and Handling Using a Single Lifting Point

The following procedures describe how to lift and lower plates using a single lifting point.

4.1.1.1 Laying Down Plates Using a Single Lifting Point

To properly lay a plate on a work surface using a single lifting point, do the following:



WARNING!

Crushing hazard – risk of death or serious injury. Inadequate lifting equipment can fail and could cause death or serious injury. Make sure all lifting equipment is rated for the load and in safe operating condition.

1. Install a lift bar or swivel hoist ring and connect it to an overhead lifting device.
 - For information about lifting using a lift bar, refer to [Section 4.1.3](#).
 - For information about lifting using swivel hoist rings, refer to [Section 4.1.4](#).
2. Lift the plate above the work surface.

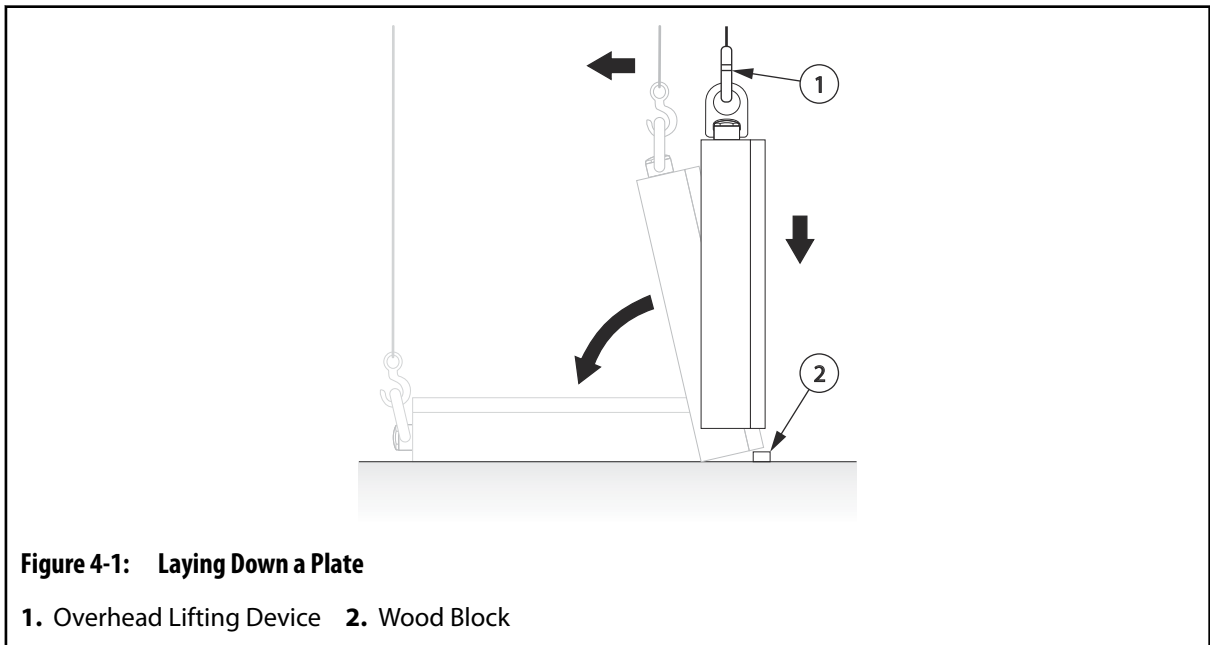

3. Secure a wood block to the work surface on the side opposite the area where the plate will be laid down.

4. Lower the plate slowly onto the edge of the secured wood block.
5. Continue to slowly lower the plate until it tips over towards the work surface.
6. Lay the plate down on the work surface.

4.1.1.2 Picking Up Plates Using a Single Lifting Point

When lifting a plate that has been laid down using a single lifting point, the lifting device may go slack just as the load is in its full vertical position. This may cause the plate to swing over-center in the opposite direction.

To prevent this from happening, do the following:



WARNING!

Crushing hazard – risk of death or serious injury. Inadequate lifting equipment can fail and could cause death or serious injury. Make sure all lifting equipment is rated for the load and in safe operating condition.

1. Install the mold or hot runner lifting equipment lift bar, swivel hoist ring, or other Husky specified lifting equipment and connect it to the overhead lifting device.
 - For information about lifting using a lift bar, refer to [Section 4.1.3](#).
 - For information about lifting using swivel hoist rings, refer to [Section 4.1.4](#).
2. Secure a wood block to the work surface near the foot of the plate. This will prevent the plate from going over-center.

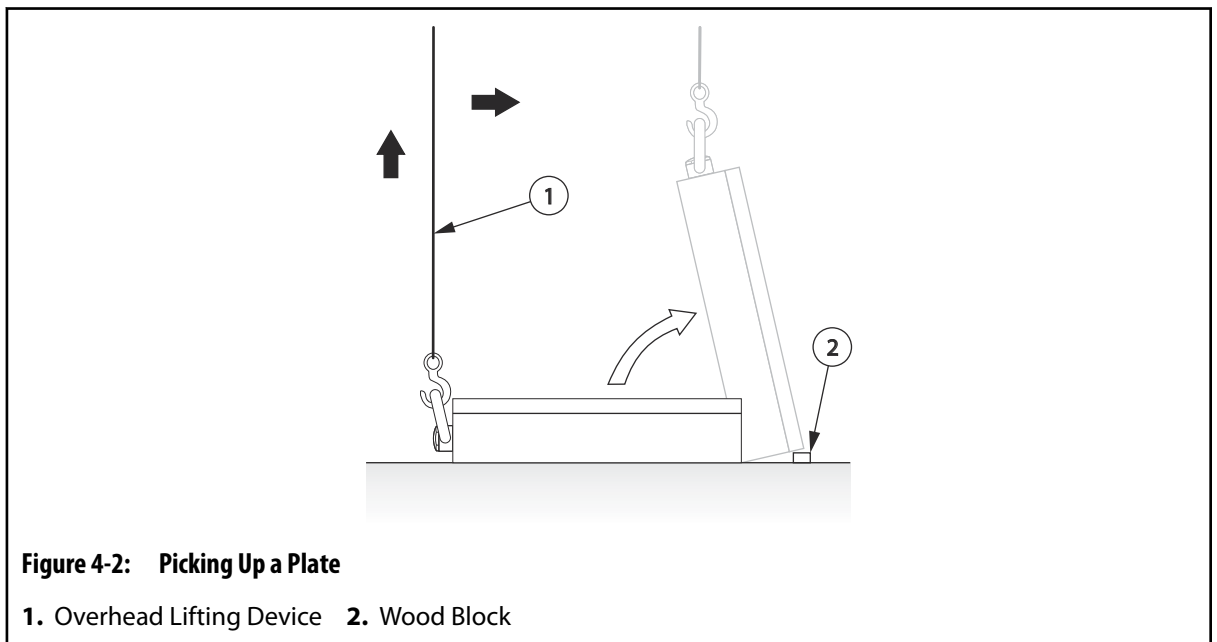

Figure 4-2: Picking Up a Plate

1. Overhead Lifting Device 2. Wood Block

3. Lift the plate until it touches the secured wood block.



WARNING!

Impact hazard – risk of serious injury. The plate could swing in a pendulum motion just as the plate is lifted off of the wood block. Lift slowly to reduce the pendulum motion. Stand clear of the possible swing area to prevent injury.

- Continue to lift the plate, keeping the tension on the lifting cable.

CAUTION!

Mechanical hazard – risk of damage to equipment. When storing the plate, make sure it is secured in the vertical or horizontal position. Do not rest the plate against another object.

- After the plate has stabilized, move it to a safe location and remove the wood block.

4.1.2 Lifting and Handling Using Multiple Lifting Points

To lift a plate using more than one lifting point, do the following:



WARNING!

Crushing hazard – risk of death or serious injury. Inadequate lifting equipment can fail and could cause death or serious injury. Make sure all lifting equipment is rated for the load and in safe operating condition.

- Install the swivel hoist rings in the designated lifting points. Make sure the swivel hoist rings are positioned on opposite sides of the plate to evenly distribute the weight when the plate is lifted vertically.

For information about lifting using swivel hoist rings, refer to [Section 4.1.4](#).

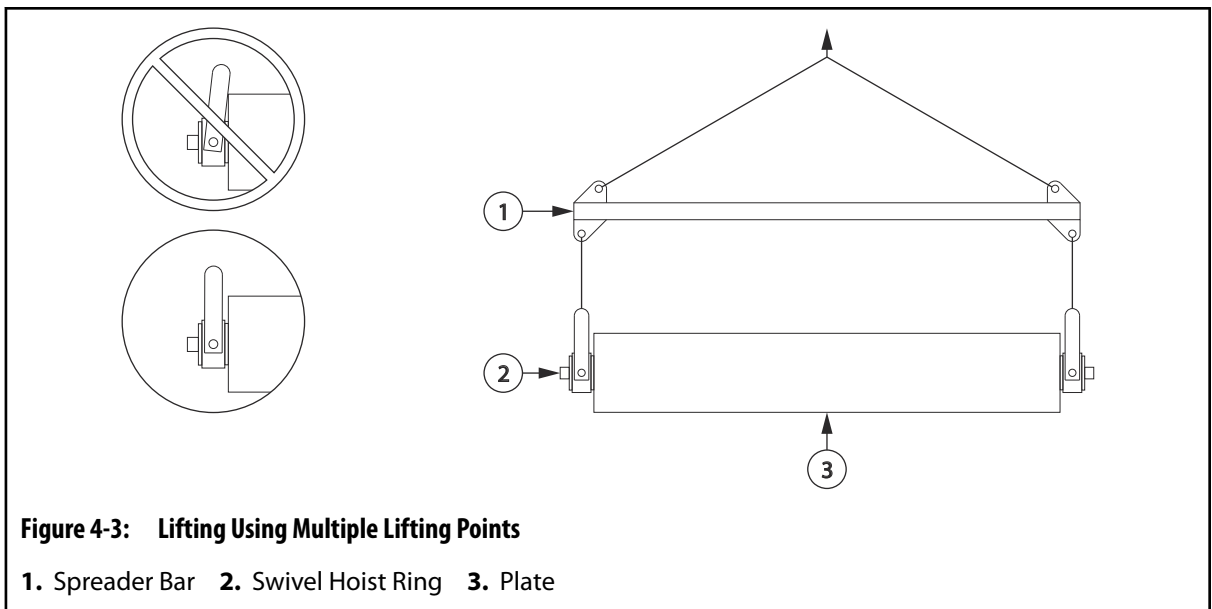

2. Connect the swivel hoist rings to an overhead lifting device. Use a spreader bar if either of the following conditions occur:
 - The pivot angle of any swivel hoist ring exceeds 90°.
 - The angle of lifting cables, slings or chains is less than 45°.
3. Lift the plate and move it to a safe location.

4.1.3 Lifting Using a Lift Bar

To properly lift plates and assemblies using a lift bar, do the following:

NOTE:

For the installation locations of the lift bars, refer to the hot runner for the markings “Lift Bar Only” or to the assembly drawings.

NOTE:

The maximum weight the bar can lift is stamped on the Husky lift bar. If using a lift bar that is not provided by Husky, make sure the lift bar is suitably rated for the weight of the mold/hot runner assembly.

1. Install the lift bar to the lifting holes on the top of the component.

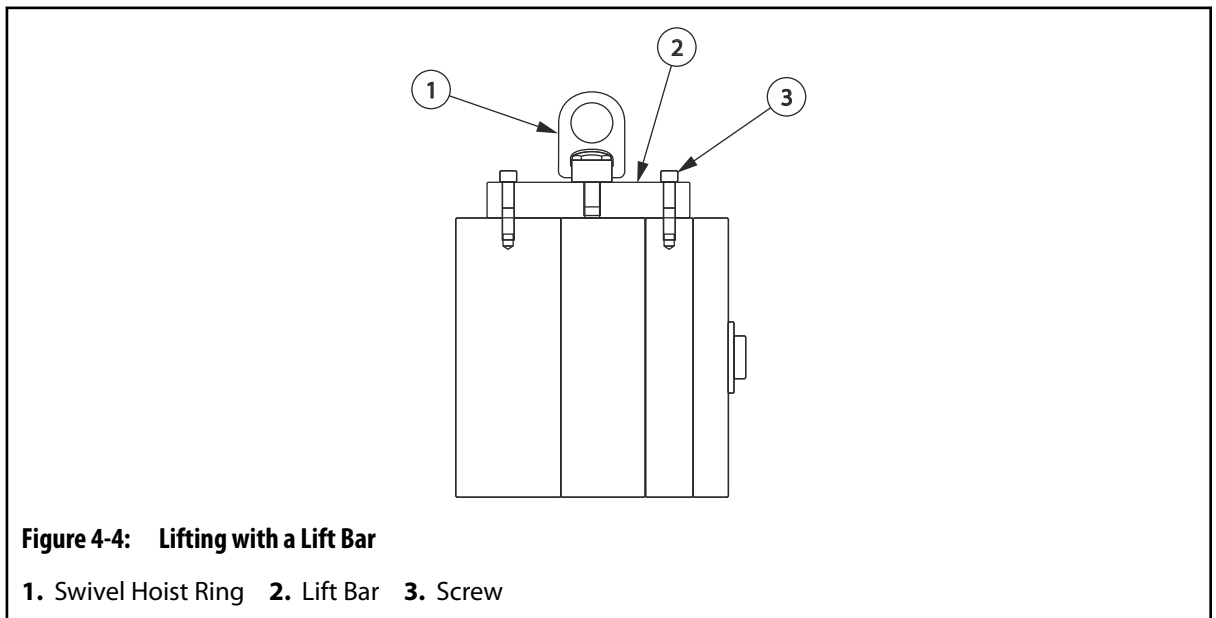

2. Torque the hoist ring to the specified value. Refer to [Section 3.7](#) for torque requirements.
3. Attach a suitable overhead lifting device to the swivel hoist ring and lift the plate or plate assembly vertically.
4. While the mold and hot runner are in operation, store the Husky provided lifting equipment together and in a readily accessible area.

4.1.4 Lifting Using Swivel Hoist Rings

When using swivel hoist rings, remember the following:

- For the installation locations of the swivel hoist rings, refer to the hot runner for the markings “Hoist Ring Only” or to the assembly drawings.
- Always make sure the swivel hoist ring is properly torqued before lifting.
- Make sure the swivel hoist ring used can support the weight of the plate or component at the chosen angle of attack.
- Do not lift more than the rated capacity.
- Depending upon the sling angle, the applied load may be more than the weight being lifted. Two point lifting of a 1000 kg (2000 lb) weight, with a sling angle of 30°, will result in an applied load of 1000 kg (2000 lb) to each hoist ring.
- After installation, make sure the hoist ring swivels and pivots freely in all directions. The side of the ring must not contact anything.
- After installation and during operation, store the Husky provided lifting equipment together and in a readily accessible area.
- Never use a hook or other lifting device which will pry or open the “U” shaped bar on center-pull hoist rings.
- Screws must be tightened to the recommended torque values.
- Do not apply shock loads. When lifting, apply force gradually.
- Do not use spacers between the hoist ring bushing and the work piece surface.
- The work piece surface must be flat, providing complete contact for the hoist ring bushing.

Metric and Imperial swivel hoist rings are available through your nearest Husky Parts Distribution Center.

Swivel hoist rings purchased from other suppliers must meet or exceed the following specifications.

Table 4-1: General Hoist Ring Specifications

Category	Specification
Material	4140 certified aircraft quality
Type	Forged hoist ring
Finish	Phosphate per DOD-P-16232F
Safety Factor	5:1
Swivel	Pivot 180° and swivel 360°
Thread	ISO 261 and ISO 965 - Coarse
Surface	Magnetic particle inspected (ASTM E709-80)
Certification	Individual certificate of conformance with the serial number specified on the hoist ring for traceability

Table 4-2: Specifications for Metric Coarse Swivel Hoist Rings

Part Number	Rated Capacity ^[1]	Torque	Thread Ø	Minimum Full Thread Depth	Pitch
2761800	1050 kg (2315 lb)	37 N·m (27 lbf·ft)	M12	24	1.75
2770570	1900 kg (4189 lb)	80 N·m (59 lbf·ft)	M16	32	2.00
2502267	4200 kg (9259 lb)	311 N·m (229 lbf·ft)	M24	48	3.00
536013	7000 kg (15432 lb)	637 N·m (470 lbf·ft)	M30	60	3.50
2761801	11000 kg (24250 lb)	1085 N·m (800 lbf·ft)	M36	72	4.00
2761803	12500 kg (27558 lb)	1085 N·m (800 lbf·ft)	M42	84	4.50

^[1] Minimum rated capacity at any pull angle (between 0° horizontal pull and 90° vertical pull)

Table 4-3: Specifications for Inch UNC Swivel Hoist Rings

Part Number	Rated Capacity ^[2]	Torque	Thread Ø	Minimum Full Thread Depth	Pitch
2732764	1130 kg (2500 lb)	38 N·m (28 lbf·ft)	1/2	1.0	13
2732765	2260 kg (5000 lb)	135 N·m (100 lbf·ft)	3/4	1.5	10
2760517	4530 kg (10000 lb)	310 N·m (229 lbf·ft)	1	2.0	8
2732766	6800 kg (15000 lb)	640 N·m (472 lbf·ft)	1 1/4	2.5	7
2732767	10880 kg (24000 lb)	1080 N·m (797 lbf·ft)	1 1/2	3.0	6

^[2] Minimum rated capacity at any pull angle (between 0° horizontal pull and 90° vertical pull)

4.2 Mounting Methods

Each hot runner is designed to be mounted to the machine using a specific method. The following describes the various methods that can be used.

4.2.1 Direct Bolting

The direct bolting method uses screws to secure the hot runner to the stationary platen. The screws are either installed through the hot runner into threaded holes in the stationary platen, or through the stationary platen into threaded holes in the hot runner.

In this method, the screws are able to carry the maximum possible load while resisting the opening force of the mold.

When using the direct bolting method, adhere to the following guidelines:

- All screws must be lubricated.
- The size, quantity and spacing of the screws must be suitable for the machine.

CAUTION!

Crushing hazard – risk of damage to equipment. Screws used to secure the hot runner to the stationary platen must meet specific requirements. Only use the screws specified in the assembly drawings. Failure to use these screws could result in equipment damage.

- Make sure only the screws specified in the assembly drawings are used.
- Torque each screw starting from the center of the hot runner and working outwards.

CAUTION!

Mechanical hazard – risk of damage to equipment. Air impact guns could produce excessive torque and damage the hot runner. Use only a torque wrench to install the hot runner.

- Use a torque wrench to install the screws and verify the torque.

4.2.2 Clamping

The clamping method uses clamps to hold the hot runner to the stationary platen. The clamps are secured to the stationary platen with screws and hold the hot runner at the operator and non-operator side clamp slots.

In this method, the clamps must be properly secured to prevent the hot runner from slipping. This may cause damage as the mold closes or cause the mold and hot runner to fall completely from the stationary platen.



WARNING!

Crushing hazard – risk of serious injury, death and/or damage to the hot runner. Clamps could loosen allowing the mold and hot runner to slip or fall completely from the stationary platen. Make sure the type, quantity, size and position of the clamps is sufficient for mounting the mold and hot runner.



IMPORTANT!

Husky assumes no responsibility for the type, quantity, size or position of the clamping equipment used and does not recommend the clamping method for securing the hot runner to the machine. It is the responsibility of the customer to make sure the clamping equipment and its installation is adequate for safely securing the hot runner.

Whenever possible, use the direct bolting method. Refer to [Section 4.2.1](#) for more information.

When using the clamping method, adhere to the following guidelines:

- Make sure the screws used to secure the clamps to the stationary platen are torqued.
- A sufficient number of clamps must be used to safely secure the mold and hot runner.
- The clamps must be positioned as close as possible to each other.
- Verify with the clamp supplier the number of clamps to use, the position and the required torque.
- Only use high strength screws with a minimum yield strength of 690 MPa (100000 psi)
- Inspect and torque the clamps regularly.

4.2.3 Quick Mold Changers and Clamping Systems

Refer to the quick mold changer or clamping system manufacturer's documentation for installation information.



IMPORTANT!

Any quick mold changer or clamping system must be interlocked appropriately with the machine's logic and guarding interlock system.

4.3 Removing and Installing the Hot Runner

The following procedures describe how to remove and install the hot runner.

4.3.1 Installing the Hot Runner



IMPORTANT!

Hot runners may not be put into service in a machine that does not comply with the provisions of Machinery Directive 2006/42/EC, as amended, and with the regulations transposing it into national law.

To install the hot runner in the machine, do the following:

1. Verify the machine nozzle orifice and radius match the sprue bushing in the hot runner. Processing problems can occur if the two systems do not match.
2. Make sure the clamp is open to maximum daylight.
3. Lock out and tag the machine and controller (if equipped). Refer to [Section 2.5](#) for more information.

CAUTION!

Mechanical hazard – risk of damage to equipment. An improperly leveled machine could make the hot runner installation difficult and cause premature component wear. Make sure the machine is leveled before installing the hot runner.

-
4. Make sure the machine is level and the platens are parallel. Refer to the machine manufacturer's documentation for more information.

NOTE:

The cavity plate may be attached to the hot runner during installation.

-
5. Install or remove the cavity plate as needed. Refer to [Section 6.6](#) for more information.
 6. Using a protective spray and a lint-free cloth, clean all mounting surfaces on the hot runner and stationary platen. Refer to [Section 3.5](#) for a list of recommended lubricants.
Remove any hard dirt, nicks or burrs with a medium India stone (240 grit oil stone).
 7. Spray all mounting surfaces on the hot runner and stationary platen with a protective spray. Refer to [Section 3.5](#) for a list of recommended lubricants.
 8. Inspect all fittings and electrical connections on the hot runner for damage. Repair or replace as necessary.

**WARNING!**

Crushing hazard – risk of death or serious injury. Inadequate lifting equipment could fail and cause death or serious injury. Make sure all lifting equipment is rated for the load and in safe operating condition.

-
9. Install and torque the lift bar to the hot runner. Refer to [Section 4.1.3](#) for more information.

**WARNING!**

Crushing hazard – risk of death or serious injury. Inadequate lifting equipment could fail and cause death or serious injury. Make sure all lifting equipment is rated for the load and in safe operating condition.

-
10. Attach an overhead lifting device to the lift bar and lift the hot runner over the mold area. Make sure the locating ring faces the stationary platen.
 11. Lower the hot runner into the mold area. If necessary, rotate the assembly 90° to fit it between the tie bars.
 12. Align the locating ring with the sprue nozzle and position the backing plate against the stationary platen.

CAUTION!

Crushing hazard – risk of damage to equipment. Screws used to secure the hot runner to the stationary platen must meet specific requirements. Only use the screws specified in the assembly drawings. Failure to use these screws could result in equipment damage.

-
13. Secure the backing plate to the stationary platen. Refer to [Section 4.2](#) for information about various mounting methods.
 14. Disconnect the overhead lifting device and remove the lift bar.

CAUTION!

Mechanical hazard – risk of damage to equipment. When installing hoses, make sure they are not routed over edges or positioned where they could rub together, causing motion or vibration damage.

-
15. Connect the cooling hoses to the hot runner.
 16. Connect the supplied heater and thermocouple cables to the designated ports on the hot runner and controller.

CAUTION!

Mechanical hazard – risk of damage to equipment. When installing cables, make sure they are not routed over edges, positioned where they could rub together, or near moving parts. The resulting motion or vibrations could damage the cable insulation.

-
17. Arrange the cables, using clamps or ties if necessary, to avoid contact with moving parts or sharp edges.

**WARNING!**

Poison hazard – risk of death or serious injury. The mold may have been sprayed with a rust inhibitor that could be toxic if ingested. To avoid contamination of food packaging products, this inhibitor must be completely removed. Clean all molding surfaces with an appropriate molding surface cleaner and discard all molded products until all traces of the rust inhibitor are removed.

-
18. If the cavity plate is installed on the hot runner, remove the rust inhibitor from all molding surfaces on the cavity plate using an appropriate molding surface cleaner.
 19. Remove all locks and tags.

4.3.2 Removing the Hot Runner

To remove the hot runner from the machine, do the following:

**WARNING!**

Hot resin spray hazard – risk of death or serious injury. Residual pressure from gases in the hot runner could cause hot resin to spray from the nozzle tips when released. Make sure the valve gates are open when turning off the heaters to relieve pressure in the hot runner.

CAUTION!

Mechanical hazard – risk of damage to the hot runner. Do not actuate the valve stems when the hot runner is cold. Damage to the valve stems, pistons and/or shear pins (if equipped) could occur. Make sure the hot runner is at operating temperature before actuating the valve stems.

1. Make sure the valve gates are open.
2. Open the mold and turn off all heaters.
3. Cool the hot runner by running coolant through it until the nozzles and manifold are at room temperature (< 25 °C or < 77 °F). This may take 1/2 to 4 hours depending on the size of the hot runner.
4. Lock out and tag the machine and controller (if equipped). Refer to [Section 2.5](#) for more information.
5. Purge all cooling water from the cooling hoses to minimize the risk of a coolant spill should a hose come loose during maintenance. Refer to the machine manufacturer's documentation for more information.
6. Disconnect all cooling hoses from the hot runner.
7. Disconnect all electrical cables and connectors from mold and hot runner.

**WARNING!**

Crushing hazard – risk of death or serious injury. Inadequate lifting equipment could fail and cause death or serious injury. Make sure all lifting equipment is rated for the load and in safe operating condition.

8. Install and torque the lift bar to the hot runner. Refer to [Section 4.1.3](#) for more information.
9. Attach an overhead lifting device to the hoist ring and lift only until the lifting chain has a slight tension on it.
10. Disconnect the backing plate from the stationary platen starting on the non-operator side, followed by the operator side.
11. Lift the hot runner out of the clamp. If necessary, rotate the hot runner 90° to fit it between the tie bars.

**WARNING!**

Crushing hazard – risk of death or serious injury. Do not work under suspended loads. To prevent injury, install safety blocks.

12. Install feet on the bottom of the hot runner to protect the hose fittings.

CAUTION!

Mechanical hazard – risk of damage to equipment. Store and secure the hot runner in the vertical or horizontal position. Do not rest the assembly against another object.

CAUTION!

Mechanical hazard – risk of damage to the hot runner. The hot runner must be set on supports if it is laid down horizontally, such as on a work bench. Damage to the nozzle tips, sprue bar and/or wires could occur.

13. Move the hot runner to a safe location.

Chapter 5 Startup and Operation

This chapter describes how to safely startup and operate the hot runner. Follow these instructions along with any in the machine manufacturer's documentation.

NOTE:

If the hot runner is installed in a Husky machine, refer to the startup instructions in the machine manufacturer's documentation.

To startup the hot runner for operation, perform the following procedures in order:

Step	Task	Reference
1	Prepare the hot runner	Section 5.1
2	Heat up the mold, hot runner and machine	Section 5.2
3	Precharge the hot runner with resin	Section 5.3
4	Produce test parts	Section 5.4



IMPORTANT!

The mold and hot runner must be installed properly by qualified personnel before production begins.

5.1 Preparing the Hot Runner

To prepare the hot runner for startup, do the following:

1. Lock out and tag the machine and controller (if equipped). Refer to [Section 2.5](#) for more information.
2. Make sure the mold and hot runner are installed properly.
3. Make sure the heaters and thermocouples are connected to the machine or a controller.
4. Make sure the resin type in the machine matches the required type indicated on the hot runner nameplate. Refer to [Section 1.7](#) for more information about the nameplate.

CAUTION!

Mechanical hazard – risk of damage to the hot runner. In the event of water leaking into the hot runner, the nozzle heaters could fail. Make sure all water is removed before starting up the hot runner.

-
5. Using compressed air, remove any water around the nozzle tips and parting lines.
 6. Make sure all safety latches have been removed from the mold and hot runner.
 7. Remove all locks and tags.

CAUTION!

Mechanical Hazard – Risk of damage to hot runner. Dry cycling the valve stems on a hot runner system is not recommended. Dry cycling can damage the valve stems, nozzle tips, and gate steel. If dry cycling is required for inspection of the hot runner, this should be kept to a minimum. If a long dry cycle of the injection molding machine is required, then it is not recommended to actuate valve stems during this operation.

5.2 Heating Up the Hot Runner, Mold and Machine

To bring the hot runner, mold and machine up to operating temperature, do the following:

1. If equipped, make sure the dryer is enabled and adjusted to the proper operating temperature.
2. Make sure the water chiller is enabled and adjusted to the proper operating temperature.
3. If equipped, make sure the mold enclosure de-humidifier, air compressor and water tower supplies are enabled.
4. Check the air pressure settings for the machine.
5. Make sure the compressed air for the mold is turned off. If the compressed air is left on as the hot runner heats up, air will leak from the system. This will cool the hot runner and delay the startup.
6. Slowly open the clamp to full shutheight.
7. Turn on the hot runner cooling system.

**WARNING!**

Hot resin spray hazard – risk of death or serious injury. Overheated resin can generate pressurized gas that when suddenly released can cause material to spray out. Do not allow resin to overheat. If the startup process is interrupted, turn off all barrel heaters and retract the injection unit to allow the hot runner to vent between the machine nozzle and the sprue bushing. For extended delays, follow the machine manufacturer's and resin supplier's procedures for machine shutdown.

8. Turn on the machine barrel heaters and allow them approximately 1/2 to 1 1/2 hours to reach operating temperature, depending on the size of the injection unit.

9. If equipped, turn on the controller.

CAUTION!

Mechanical hazard – risk of damage to the hot runner. Never operate the hot runner outside of the melt and mold temperatures indicated on the nameplate. Internal resin leakage or component damage could occur.

-
10. Set the temperature of the main manifold heaters, cross manifold heaters (if equipped) and sprue heater to the melt temperature indicated on the nameplate. Refer to [Section 1.7](#) for more information about the nameplate.



WARNING!

Hot resin spray hazard – risk of death or serious injury. The sprue heater must be turned on when the manifold heaters are turned on. Failure to do so could result in the generation of dangerous pressure levels in the manifold, resulting in the sudden release of hot resin.

-
11. Turn on the main manifold heaters, cross manifold heaters (if equipped) and sprue heater (if equipped) zones. Wait for the heaters to reach operating temperature. Wait an additional 10 minutes or more of soak time to make sure the resin has reached the operating temperature.
 12. Make sure the main manifold heaters and the cross manifold heaters (if equipped) reach the set temperature.
 13. Turn on the transfer bushing heaters (if equipped) zones. Wait for the heaters to reach the operating temperature and then wait an additional 10 minutes or more of soak time to make sure the resin has reached the operating temperature.
 14. Open the process material feed. Refer to the machine manufacturer's documentation for more information.

5.3 Precharging the Hot Runner

To precharge the hot runner with resin, do the following:

1. Close the clamp and apply tonnage.



WARNING!

Hot resin spray hazard – risk of death or serious injury. Molten resin under high pressure can suddenly release and spray out from the machine nozzle. Before purging the barrel or shooting pot, clear the area of all non-essential personnel and wear personal protective equipment consisting of a heat-resistant coat, heat-resistant gloves and a full face shield over safety glasses.

-
2. Purge the injection unit. Refer to the machine manufacturer's documentation for more information.

3. Clean the machine nozzle, stationary platen and purge guard of any resin deposits. Refer to the machine manufacturer's documentation for more information.
4. Make sure the machine nozzle is firmly seated against the sprue bushing.
5. Turn on the nozzle heaters and allow them approximately 5 to 7 minutes before mold operation to reach operating temperature.

CAUTION!

Mechanical hazard – risk of damage to equipment. Do not allow nozzle tips to stay energized for more than 10 minutes without injecting resin. Resin residing in the nozzle tip area will degrade.

-
6. While the nozzle heaters are reaching operating temperature, do the following:
 - a. Turn on the extruder screw to start plasticizing the resin.
 - b. Repeat [step 2](#) to [step 3](#).
 7. Move the machine nozzle forward until it is firmly seated against the sprue bushing.

NOTE:

The hot runner channels are properly filled with resin when the injection piston stops before making contact with the injection housing.

-
8. Inject resin into the hot runner until the injection piston stops. The piston must stop before it makes contact with the injection housing. If the piston makes contact with the injection housing, inject resin again.
 9. Once the injection piston stops, start the extruder screw and make sure it retracts fully.

5.4 Producing Test Parts

To produce test parts that will verify the settings and functions for the hot runner and machine, do the following:

1. Make sure the nozzle heaters have not timed out. If the nozzle heaters have timed out, do the following:
 - a. Enable the heaters and wait approximately 5 to 7 minutes to reach operating temperature.
 - b. Purge the injection unit. Refer to the machine manufacturer's documentation for more information.
 - c. Clean the machine nozzle, stationary platen and purge guard of any resin deposits. Refer to the machine manufacturer's documentation for more information.
2. Close the clamp and apply tonnage.
3. Make sure the machine nozzle is firmly seated against the sprue bushing.
4. Reduce the injection pressure to 70 bar (1000 psi) .
5. Disable all ejector functions to prevent the machine from automatically ejecting parts.
6. Cycle the machine once in normal mode to produce a set of parts.

- 7.** Check that all parts have been properly molded.
- 8.** Manually control the ejector functions to eject the parts.
- 9.** If all cavities are producing parts, reset the injection pressure to the recommended value.
- 10.** Cycle the machine four times in normal mode to produce parts. This will remove any air trapped in the resin.
- 11.** Visually inspect the last set of parts to verify the part quality. Repeat [step 10](#) until the part quality is satisfactory.
- 12.** Enable the ejector functions.
- 13.** If equipped, enable the product handling equipment.
- 14.** Cycle the machine 10 times in semi-cycle mode. During each cycle, if equipped, make sure the product handling equipment properly transfers the parts to the conveyor.
- 15.** Enable the auto-cycle mode for the machine and begin production.

Chapter 6 Maintenance

This chapter describes the maintenance tasks required to maintain the hot runner. Refer to [Section 6.1](#) for a full list of maintenance procedures.

NOTE:

Unless specified otherwise, all bolts, screws, fittings and other hardware should be torqued to the values listed on the assembly drawings specific to the hot runner.

**WARNING!**

Risk of injury. When entering the molding area, personal protective equipment must be worn to guard against burns, abrasions, hearing, foot, eye, and face hazards and any other procedure specific hazards listed in the manual.

**WARNING!**

Chemical hazard - Some of the chemicals used when servicing or maintaining Husky equipment are potentially hazardous and could cause injury and illness. Before storing, handling, or working with any chemical or hazardous material, thoroughly read and understand each applicable Material Safety Data Sheet (MSDS), use recommended personal protective equipment and follow the manufacturer's instructions.

**IMPORTANT!**

The procedures contained in this chapter were written for a standard hot runner and do not take special options into consideration.

6.1 Scheduled and Non-Scheduled Maintenance

Throughout the life of the mold and hot runner, various systems and components will need to be inspected and serviced on a scheduled or non-scheduled basis.

There are two types of maintenance procedures:

- Preventive procedures are performed at scheduled intervals
- Service procedures are performed when required

6.1.1 Preventive Maintenance

The following procedures must be performed when either the interval or cycle count is reached as part of the recommended preventive maintenance program for the mold and hot runner.

Interval	Cycles	Task Description	Reference
Every 6 Months	800,000	Test the hot runner heaters	Section 6.5
Every 12 Months	1,600,000	Remove excess resin from the manifold plate	Section 6.27
		Inspect the valve stem and piston assemblies	Section 6.12
Every 18 Months	2,000,000	Replace the double delta seals	Section 6.13

6.1.2 Service Procedures

The following procedures are to be performed only when needed.

Procedure	Reference
Adjusting the thermocouple wire length	Section 6.24
Changing the resin color	Section 6.2
Extending nozzle and sprue heater wire leads	Section 6.3
Measuring preload	Section 6.4
Removing insulating gate bubbles	Section 6.19
Removing resin from the hot runner	Section 6.26
Removing resin from the manifold plate	Section 6.27
Removing and installing manifold bushings	Section 6.20
Removing and installing manifolds	Section 6.9
Removing and installing nozzle heaters	Section 6.17
Removing and installing nozzle housings	Section 6.16
Removing and installing nozzle tip insulators	Section 6.18
Removing and installing nozzle tips	Section 6.14
Removing and installing the backing plate	Section 6.7
Removing and installing the cavity plate	Section 6.6
Removing and installing the center plate (if equipped)	Section 6.8

Procedure	Reference
Removing and installing the sprue bushing	Section 6.22
Removing and installing the sprue heater	Section 6.21
Removing and installing transfer bushings (if equipped)	Section 6.23
Removing and installing valve stems	Section 6.12
Removing and installing VG-LX/EX backup pads	Section 6.10
Removing and installing VG-SX cylinders	Section 6.11
Removing air and water plugs	Section 6.25

6.2 Changing the Resin Color

To change the color of the resin, do the following:

1. Lock out and tag the machine and controller (if equipped). For machine lockout and tag procedures refer to the machine documentation.
2. Remove all traces of the original resin from the material feed equipment.
3. Depending on application restrictions, add one of the following to the material feed equipment to reduce the cleaning time required:
 - Purge compound
 - Natural (uncolored) resin
 - New colored resin
4. Remove all locks and tags.
5. Power up the machine and turn on the controller (if equipped).



WARNING!

Hot resin spray hazard – risk of serious injury. Molten resin under high pressure can suddenly release and spray out from the machine nozzle. Before purging the injection unit, clear the area of all non-essential personnel and wear personal protective equipment consisting of a heat-resistant coat, heat-resistant gloves and a full face shield over safety glasses.

6. Purge the injection unit until all traces of the old color are eliminated. For instructions, refer to the machine manufacturer's documentation.
7. Increase the injection speed to the maximum value allowed by the application.
8. Reduce the hold time and cooling time to the minimum values allowed by the application.
9. Increase the temperature of the hot runner nozzle tips, manifold and sprue by 20 to 30 °C (68 to 86 °F).

10. Repeat [step 3](#) to replenish the material feed system, if required.
11. Produce a series of test parts until all traces of the old color are eliminated.
12. When the color change is complete, decrease the temperature of the nozzle tips, manifold and sprue by 20 to 30 °C (68 to 86 °F) .
13. Return the hold time, cooling time and injection speed back to their original values.
14. Fill the material feed equipment with the new resin.

6.3 Extending Nozzle and Sprue Heater Wire Leads

The following procedure describes how to install the nozzle and sprue heater lead splice kit (P/N 4047310) to extend the length of the nozzle and sprue heater wires. This kit may be required on systems where the wire leads are not long enough to reach the electrical connectors.



IMPORTANT!

This procedure is only for nozzle and sprue heater leads when standard lead lengths are not long enough.

This procedure is not to be used for extending thermocouple wire leads. Splicing thermocouple wires will cause false and/or erratic temperature readings.

When required, standard thermocouples are available with longer wire lead lengths.

To install the kit, do the following:

1. Strip the ends of the wire and the wire supplied with the kit until 6 mm (0.2 in) of wire lead is exposed on both.
2. Slide heat shrink tubing over the butt connector. Make sure the butt connector is centered in the tubing.

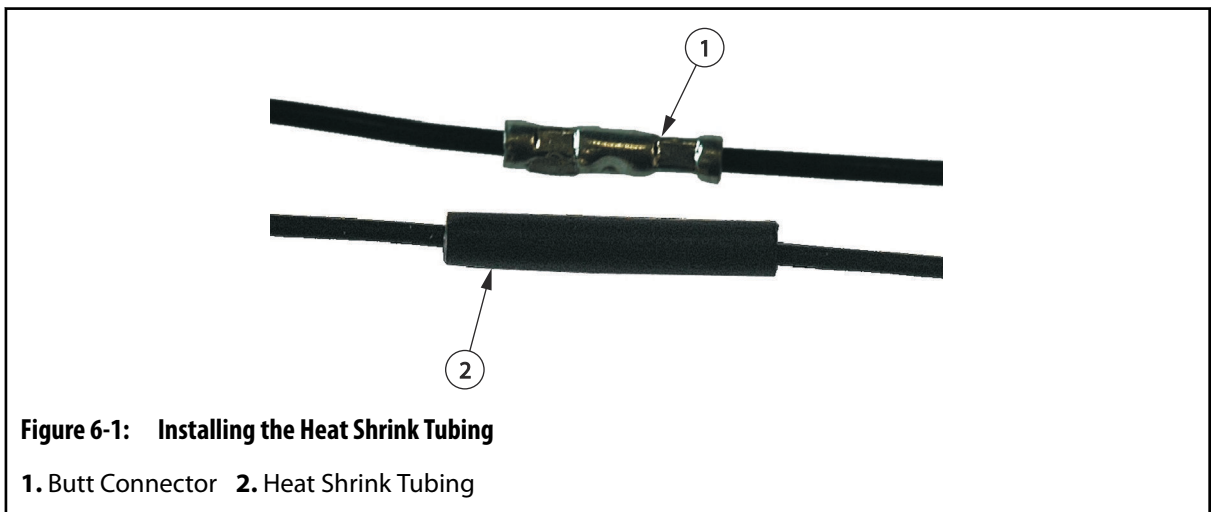

Figure 6-1: Installing the Heat Shrink Tubing

1. Butt Connector 2. Heat Shrink Tubing

3. Insert the wires into both ends of the butt connector until no wire lead is visible.

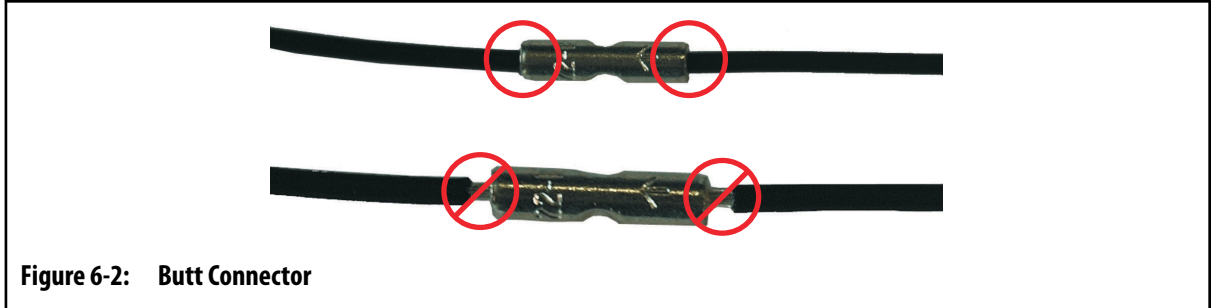

Figure 6-2: Butt Connector

4. Using a crimping tool, crimp one end of the butt connector at a time.
5. Shrink the tubing using a heat gun.
6. Seal the ends of the heat shrink tubing where the tubing meets the wire lead insulation.



Figure 6-3: Completed Wire Lead Extension

6.4 Measuring Preload

Preload measurements from various sections of the hot runner must be taken and verified before the plates are assembled and when the hot runner is at room temperature (< 25 °C or < 77 °F). Damage to the plates, backup pads or cylinders, and nozzle stacks could occur if the preload measurements are not within the allowed tolerance.



IMPORTANT!

Always measure preload in more than one section of the hot runner to make sure preload is consistent.

Maintaining proper preload will help prevent molten plastic from leaking inside the hot runner.

Perform the following procedures as applicable to determine the preload on the manifolds and/or cross manifold (if equipped):

Procedure	Reference
Measuring Preload for Manifolds in VG-LX/EX Systems	Section 6.4.1
Measuring Preload for Manifolds in VG-SX Systems	Section 6.4.2
Measuring Preload for Cross Manifolds (If Equipped) in Two Plate System	Section 6.4.3
Measuring Preload for Cross Manifolds (If Equipped) in Three Plate System	Section 6.4.4

6.4.1 Measuring Preload for Manifolds in VG-LX and EX Systems

To measure the preload on a manifold, do the following:

CAUTION!

Mechanical hazard – risk of damage to the hot runner. Do not tighten the screws that secure the manifolds to reduce the preload values. These screws should be hand tightened and then turned counter-clockwise 1/4 turn before preload measurements are taken.

1. Make sure the screws that secure the manifold to the manifold plate are hand-tightened and then turned counter-clockwise 1/4 turn.
2. Determine the height of the backup pads from the assembly drawings. Record the value as measurement *A*.
3. Using a depth micrometer, measure the distance from the top face of the manifold plate to the face of the manifold. Record this value as measurement *B*.

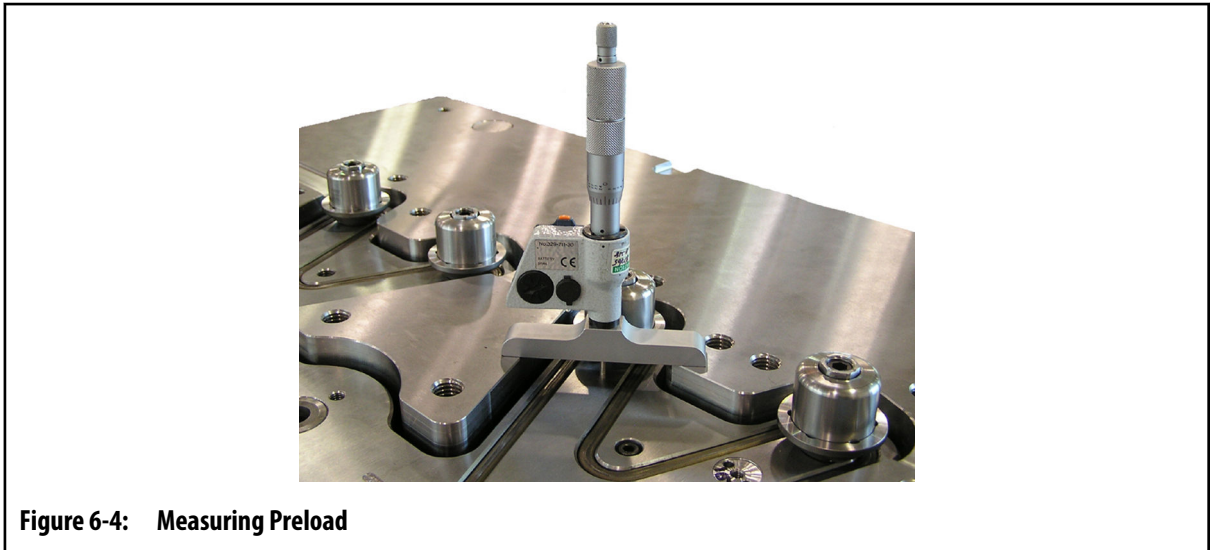

Figure 6-4: Measuring Preload

4. Complete the following calculation to determine the preload:
$$A - B = \text{Preload}$$
5. Repeat [step 2](#) to [step 4](#) for all other corners of the manifold to make sure the preload measurements are consistent.
6. Compare the preload values to the C or C1 dimension values listed on the Tip Chart on the assembly drawings.

If the measured preload is not within the tolerances given on the Tip Chart, check all measurements and review the assembly for obstructions or debris. Repeat [step 2](#) to [step 6](#) until the preload measurements are within tolerance.

6.4.2 Measuring Preload for Manifolds in VG-SX Systems

To measure the preload on a manifold, do the following:

CAUTION!

Mechanical hazard – risk of damage to the hot runner. Do not tighten the screws that secure the manifolds to reduce the preload values. These screws should be hand tightened and then turned counter-clockwise 1/4 turn before preload measurements are taken.

1. Make sure the screws that secure the manifold to the manifold plate are hand-tightened and then turned counter-clockwise 1/4 turn.
2. Determine the height of the cylinders from the assembly drawings. Record the height as measurement A.
3. Using a depth micrometer, measure the distance from the top face of the manifold plate to the face of the manifold(s). Subtract this value from the height of the cylinders and record the measurement as measurement B.

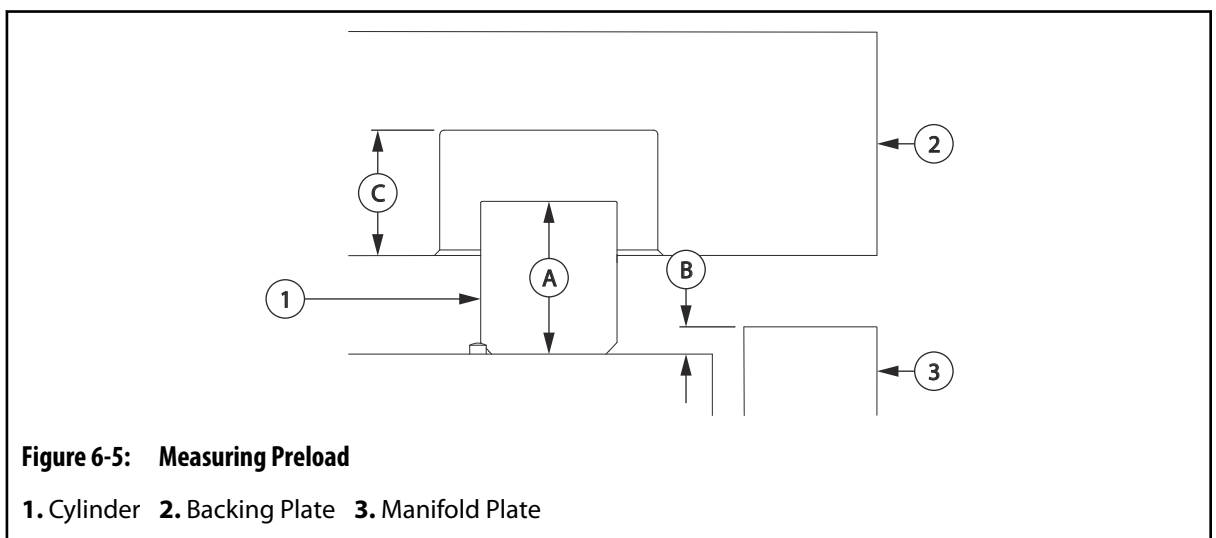

4. On the backing plate, measure the distance from the manifold-plate-to-backing-plate surface to the sealing surface in the cylinder bore. Record the distance as measurement C.

NOTE:

The sealing surface is where the cylinder contacts the backing plate.

5. Complete the following calculation to determine the preload:

$$A - (B + C) = \text{Preload}$$
6. Repeat [step 2](#) to [step 5](#) for all other corners of the manifold to make sure the preload measurements are consistent.
7. Compare the preload values to the C or C1 dimension values listed on the Tip Chart on the assembly drawings.

If the measured preload is not within the tolerances given on the Tip Chart, check all measurements and review the assembly for obstructions or debris. Repeat [step 2](#) to [step 7](#) until the preload measurements are within tolerance.

6.4.3 Measuring Preload for Cross Manifolds in Two Plate Systems (If Equipped)

To measure the preload on a cross-manifold, do the following:

CAUTION!

Mechanical hazard – risk of damage to the hot runner. Do not tighten the screws that secure the manifolds to reduce the preload values. These screws should be hand tightened and then turned counter-clockwise 1/4 turn before preload measurements are taken.

1. Make sure the screws that secure the cross manifold to the manifolds are hand-tightened and then turned counter-clockwise 1/4 turn.
2. Remove the C-rings, if equipped.
3. Using a depth micrometer, measure the distance from the top face of the cross manifold to the top face of the backup pad (LX or EX) or cylinder (SX). Record value as measurement A.

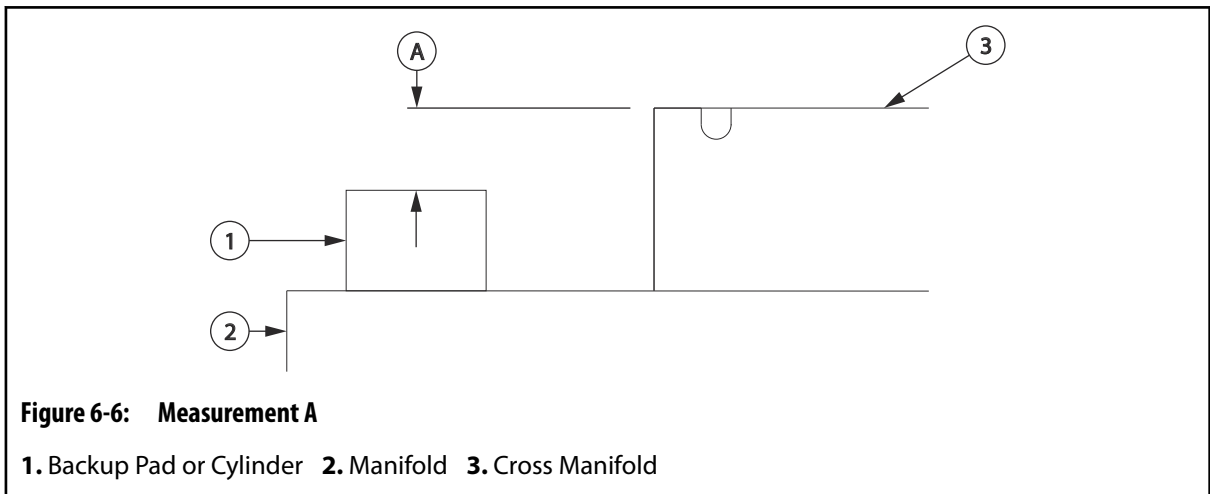

4. Make sure the backing plate is laying on a work bench with the pocket facing up.
5. Using a depth micrometer, measure the distance from the top face of the backing plate to the face inside the bore where the backup plate spring pack will make contact. Record value as measurement B.

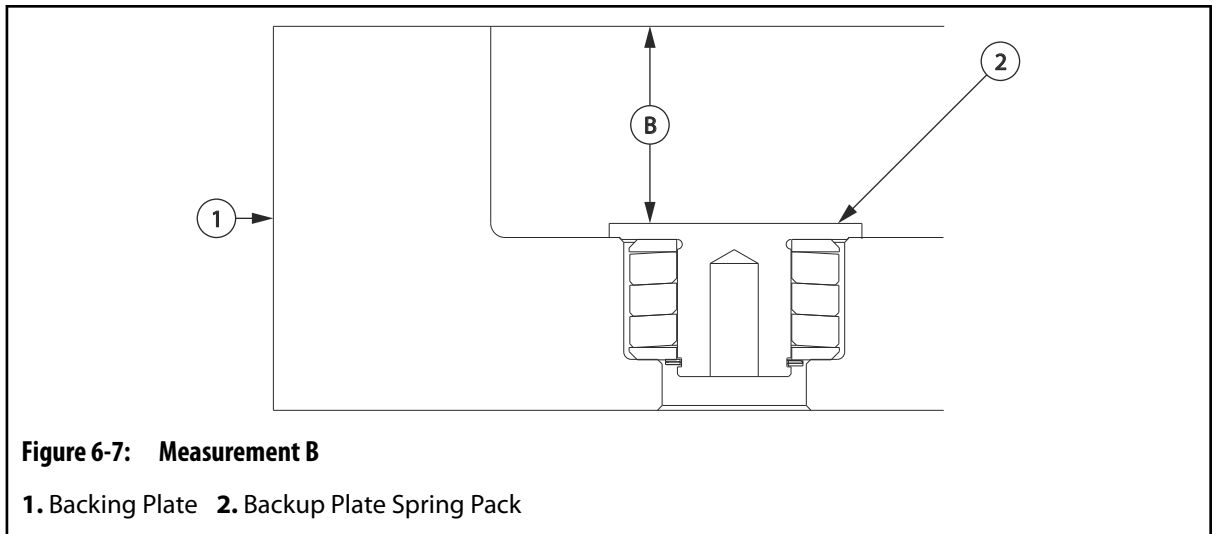

6. Complete the following calculation to determine the preload:
 $A - B = \text{Preload}$
7. Repeat [step 1](#) to [step 6](#) for all other corners of the cross manifold to make sure the preload measurements are consistent.
8. Compare the preload measurements to the C2 dimension value listed on the Tip Chart on the assembly drawings.
 If the measured preload is not within the tolerances given on the Tip Chart, check all measurements and review the assembly for obstructions or debris. Repeat [step 1](#) to [step 8](#) until the preload measurements are within tolerance.

6.4.4 Measuring Preload for Cross Manifolds in Three Plate Systems (If Equipped)

To measure the preload on a cross-manifold, do the following:

CAUTION!

Mechanical hazard – risk of damage to the hot runner. Do not tighten the manifold or cross manifold hold down bolts to reduce the preload values. Manifold and cross manifold hold down bolts should be hand tightened and then turned counter-clockwise 1/4 turn before preload measurements are taken.

1. Using a depth micrometer, measure the distance from the top of the transfer bushing to the top face of the center plate. Record the value as measurement A.

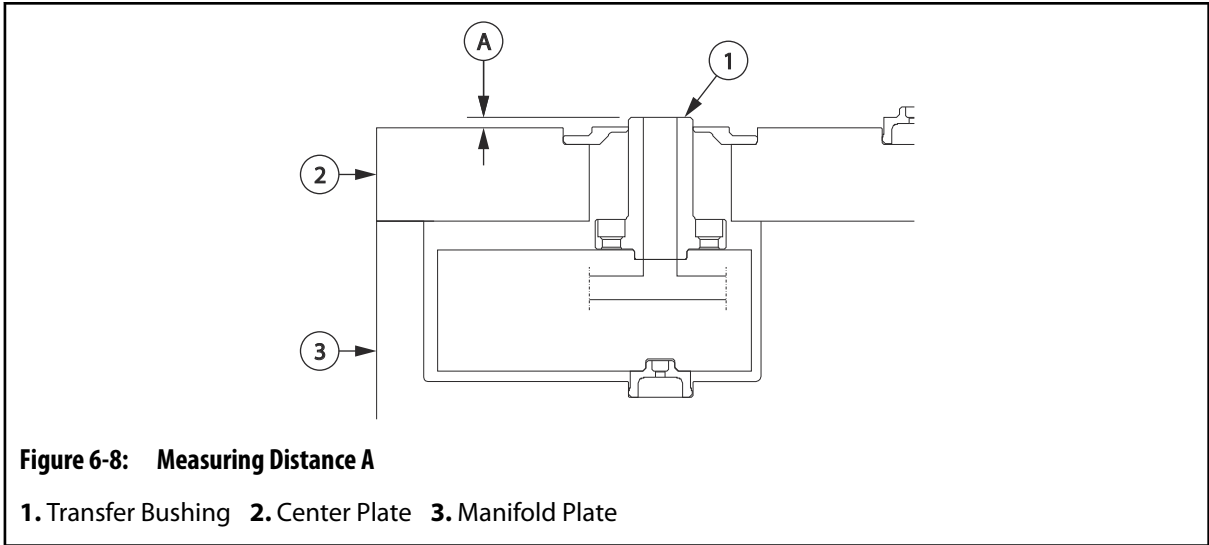

- Using a depth micrometer, measure the distance from the top face of the backing plate to the face inside the bore where the backup plate spring pack will make contact. Record value as measurement B.

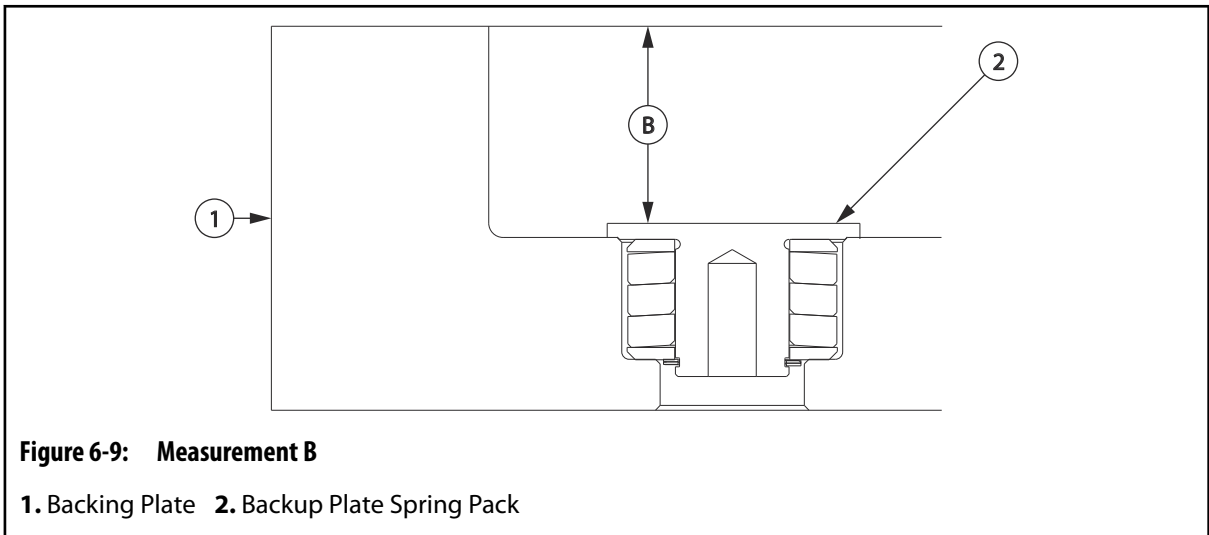

- Measure the thickness of the center plate and record the value as measurement C.
- Determine the cold clearance between the cross manifold and the transfer bushing listed on the Tip Chart in the assembly drawings. Refer to [Section 6.4.1](#) for more information. Record the value as measurement D.
- Complete the following calculation to determine the preload:

$$A - (B + C + D) = \text{Preload}$$
- Repeat [step 1](#) to [step 5](#) for all other corners of the cross manifold to make sure the preload measurements are consistent.
- Compare the preload measurements to the C2 dimension value listed on the Tip Chart on the assembly drawings.

If the measured preload is not within the tolerances given on the Tip Chart, check all measurements and review the assembly for obstructions or debris. Repeat [step 1](#) to [step 7](#) until the preload measurements are within tolerance.

6.5 Testing Heaters

To confirm a heater is functioning properly, do the following:

1. With the heater at or near room temperature, use an ohmmeter to measure the resistance through the heater. Refer to the electrical schematic for the required ohms measurement.

The normal tolerance for all heaters is $\pm 15\%$.



IMPORTANT!

A common problem with heaters is moisture absorption due to the hygroscopic nature of the insulation. A heater with a low case to center conductor insulation reading ($<10K \Omega$) should be baked out and retested to determine if moisture was the cause. Contact Husky for more information.

-
2. Using an ohmmeter, measure the resistance through each lead to ground. A measurement from either lead to ground that is below $100K \Omega$ indicates a short to ground. A measurement from $100K \Omega$ to $1M \Omega$ is often associated with a wet heater.

A measurement greater than $1M \Omega$ is good.

NOTE:

A short reading can be the result of either a pinched wire or a broken heater element. Inspect the wires first to make sure there are no pinched or damaged lead wires. A heater wire can be spliced, however, this should only be done by a certified electrician. The splice should include dual layer heat shrink tubing with an adhesive inner layer to avoid potential water shorts. The heat shrink should be rated for $150 \text{ }^\circ\text{C}$ ($203 \text{ }^\circ\text{F}$) minimum.

NOTE:

Refer to the electrical schematics for resistance information.

6.6 Removing and Installing the Cavity Plate

Removing the cavity plate provides access to wiring, nozzle tips, nozzle heaters and gates. The cavity plate can be removed when the mold and hot runner assembly is in the machine or on a work bench.

CAUTION!

Risk of damage to the sealing surfaces. Hot runner nozzles must be at room temperature ($<25 \text{ }^\circ\text{C}$ or $<77 \text{ }^\circ\text{F}$) before removing or installing the cavity plate to avoid damage to the sealing surfaces.

6.6.1 Removing the Cavity Plate On a Work Bench

To remove the cavity plate from the hot runner when the assembly is on a work bench, do the following:

NOTE:

The following procedure requires the use of an overhead lifting device. Refer to [Section 4.1](#) for lifting and handling instructions.

CAUTION!

Mechanical hazard – risk of damage to the hot runner. Make sure all valve stems are in the open position during tool shutdown.

1. Remove the hot runner and cavity plate assembly from the machine and set it on a work bench with the nozzles facing up. Refer to [Section 4.3](#) for more information.

CAUTION!

Mechanical hazard – risk of damage to the nozzle sealing surfaces. The temperature of the nozzle tips must cool to room temperature <25 °C (<77 °F) before the cavity plate is removed. Damage to the nozzle sealing surfaces will occur if the temperature is too high.

2. Remove the screws that secure the cavity plate to the hot runner.



WARNING!

Crushing hazard – risk of death or serious injury. Inadequate lifting equipment can fail and could cause death or serious injury. Make sure all lifting equipment is rated for the load and in safe operating condition.

3. Install hoist rings in the designated lifting points marked on the cavity plate.

CAUTION!

Mechanical hazard – risk of damage to the mold and hot runner. Lift the cavity plate slowly until the alignment dowels are cleared. Damage to the cavity plate and/or alignment dowels could occur.

4. Attach an overhead lifting device to the hoist rings and lift the cavity plate. Use the pry slots between the plate and hot runner to help separate the cavity plate.

**WARNING!**

Crushing hazard – risk of death or serious injury. Do not work under suspended loads. To prevent injury, install safety blocks.

5. If equipped, install feet on the bottom of the cavity plate to protect the hose fittings.
6. Move the cavity plate out of the work area. Store the plate in a location where the plate cannot fall or tip over.
7. If equipped, remove the nozzle tip insulators from the nozzle tips and/or cavity plate. Refer to [Section 6.18](#) for more information.
8. Remove any insulating gate bubbles on the nozzle tips or in the cavity plate gate details. Refer to [Section 6.19](#) for more information.

6.6.2 Installing the Cavity Plate On a Work Bench

To secure the cavity plate to the hot runner when the assembly is on a work bench, do the following:

NOTE:

The following procedure assumes the cavity plate was removed as described in [Section 6.6.1](#)

NOTE:

The following procedure requires the use of an overhead lifting device. Refer to [Section 4.1](#) for lifting and handling instructions.

CAUTION!

Mechanical hazard – risk of damage to the hot runner. Make sure all valve stems are in the still in the open position prior to installation.

1. Make sure the hot runner is on a work bench with the nozzle tips facing up. The hot runner must be supported by two blocks.
2. Make sure the nozzle and cavity plate sealing diameters are clean and free of burrs or oil.

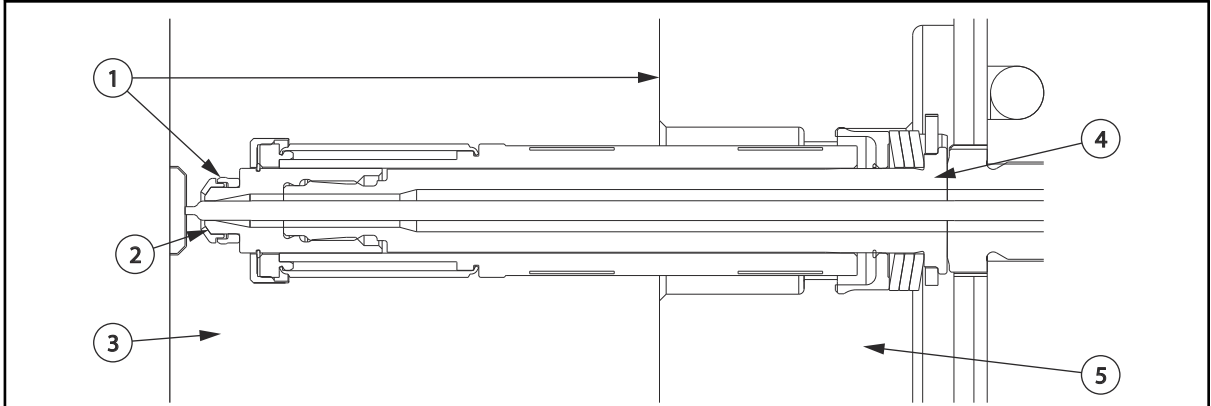

Figure 6-10: Cavity and Nozzle Sealing Diameters

1. Nozzle and Cavity Plate Sealing Diameters 2. Gate Bubble 3. Cavity Plate 4. Nozzle Housing 5. Manifold Plate

- 3. Apply a static application grease to the hot runner alignment dowels. Refer to [Section 3.5](#) for information about recommended lubricants.
- 4. If equipped, install a nozzle tip insulator on each nozzle tip. Refer to [Section 6.18](#) for more information.



WARNING!

Crushing hazard – risk of death or serious injury. Inadequate lifting equipment can fail and cause death or serious injury. Make sure all lifting equipment is rated for the load and in safe operating condition.

- 5. Install hoist rings in the designated lifting points marked on the cavity plate.
- 6. Attach an overhead lifting device to the hoist rings and lift the cavity plate over the hot runner.



IMPORTANT!

When assembling the cavity plate to the hot runner, special attention should be given to preventing damage to the nozzle tips, valve stems and wires. The cavity plate should mate with the hot runner without any resistance. If resistance is encountered, remove the plate and check for any interference points.

CAUTION!

Mechanical hazard – risk of damage to equipment. Do not force the plate into position as serious damage to the nozzle tips, valve stems and wires can result.

CAUTION!

Mechanical hazard – risk of damage to the mold and hot runner. The nozzles and manifold must be at room temperature (< 25 °C or < 77 °F) before the cavity plate is connected to the hot runner. Severe damage to the nozzle and cavity plate sealing diameters can result if the mold is still hot.

7. Align the cavity plate with the alignment dowels and lower the plate onto the hot runner. Make sure the wires in the wire channels are not pinched between the plates while closing.
8. Disconnect the overhead lifting device and remove the hoist rings.
9. Remove the feet from the bottom of the cavity plate.
10. Install safety latch bars between the cavity plate and hot runner on both sides of the assembly. A minimum of two safety latch bars are required.
11. Install the screws that secure the cavity plate to the hot runner and torque them to the specified value. Refer to the manufacturer's documentation for torque requirements.
12. Check the electrical circuit with an ohmmeter to make sure no wires were damaged during installation. Refer to the electrical schematic to identify each zone.

6.6.3 Removing the Cavity Plate In the Machine

To remove the cavity plate from the hot runner when the assembly is in the machine, do the following:



WARNING!

Hot resin spray hazard – risk of serious injury. Residual pressure from gases in the hot runner could cause hot resin to spray from the nozzle tips when released. Make sure the valve gates are open when turning off the heaters to relieve pressure in the hot runner.

CAUTION!

Mechanical hazard – risk of damage to the hot runner. Do not actuate the valve stems when the hot runner is cold. Damage to the valve stems could occur.

1. Open the valve gates.
2. Cool the mold by running coolant through it until the hot runner nozzles and manifold(s) are at room temperature (< 25 °C or < 77 °F). This may take 1/2 to 4 hours depending on the size of the hot runner.
3. Open the clamp.
4. Lock out and tag the machine and controller (if equipped). Refer to [Section 2.5](#) for more information.
5. Purge all cooling water from the cooling hoses to minimize the risk of a coolant spill should a hose come loose during maintenance. Refer to the machine manufacturer's documentation for more information.

6. Install safety latch bars between the cavity plate and hot runner on both sides of the assembly. A minimum of two safety latch bars are required.

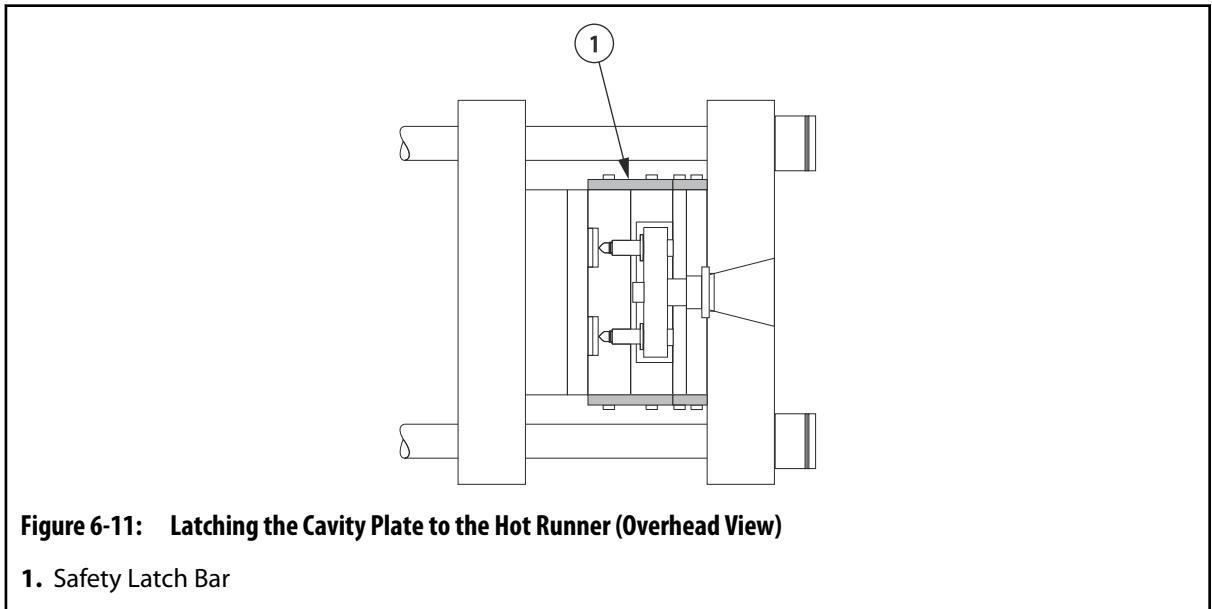

CAUTION!

Mechanical hazard – risk of damage to the nozzle sealing surfaces. The temperature of the nozzle tips must cool to room temperature <25 °C (<77 °F) before the cavity plate is removed. Damage to the nozzle sealing surfaces will occur if the temperature is too high.

7. Remove the screws that secure the cavity plate to the hot runner.
8. Remove all locks and tags.
9. Reduce the clamp opening and closing speed.
10. Slowly close the clamp.
11. Lock out and tag the machine and controller (if equipped).
12. Remove all safety latch bars.

CAUTION!

Mechanical hazard – risk of damage to the machine, mold and hot runner. Make sure the hoses attached to the cavity plate are long enough to allow latching without damaging the hoses. In some cases it may be necessary to relieve residual pressure in the system and then disconnect the hoses.

13. Install safety latch bars between the cavity plate and core plate on both sides of the assembly. A minimum of two safety latch bars are required.
14. Remove all locks and tags.

CAUTION!

Mechanical hazard – risk of damage to the mold and hot runner. The nozzles and manifold must be at room temperature (< 25 °C or < 77 °F) before the cavity plate is separated from the hot runner. Severe damage to the nozzle and cavity plate sealing diameters could result if the mold is still hot.

15. Open the clamp.
16. Lock out and tag the machine and controller (if equipped).
17. If equipped, remove the nozzle tip insulators from the nozzle tips and/or cavity plate. Refer to [Section 6.18](#) for more information.
18. Remove any insulating gate bubbles on the nozzle tips or in the cavity plate gate details. Refer to [Section 6.19](#) for more information.

6.6.4 Installing the Cavity Plate In the Machine

To secure the cavity plate to the hot runner when the assembly is in the machine, do the following:

NOTE:

The following procedure assumes the cavity plate was removed as described in [Section 6.6.3](#).

1. Lock out and tag the machine and controller (if equipped). Refer to [Section 2.5](#) for more information.
2. Make sure the nozzle and cavity plate sealing diameters are clean and free of burrs or oil.

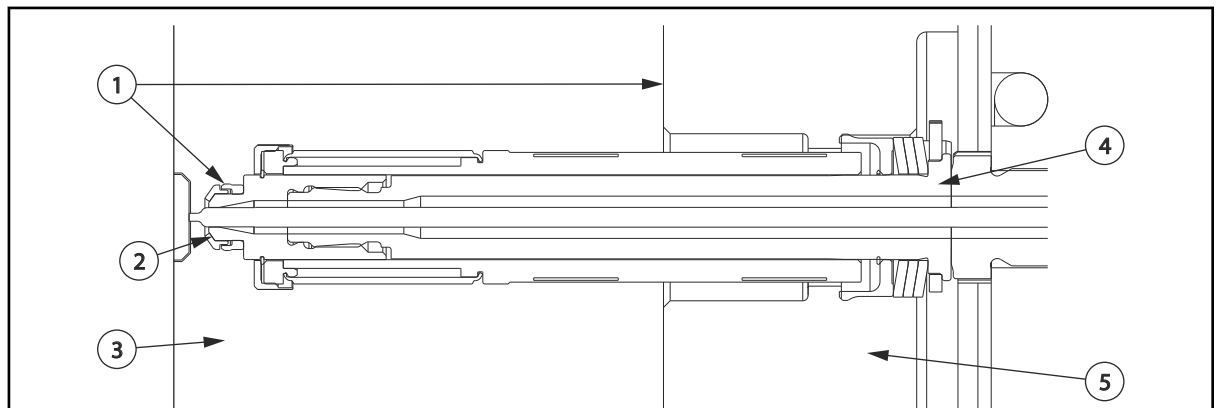

Figure 6-12: Cavity and Nozzle Sealing Diameters

1. Nozzle and Cavity Plate Sealing Diameters
 2. Gate Bubble
 3. Cavity Plate
 4. Nozzle Housing
 5. Manifold Plate
3. Apply a static application grease to the hot runner alignment dowels. Refer to [Section 3.5](#) for information about recommended lubricants.
 4. If equipped, install the nozzle tip insulators. Refer to [Section 6.18](#) for more information.
 5. Remove all locks and tags.
 6. Reduce the clamp opening and closing speed.

CAUTION!

Mechanical hazard – risk of damage to the mold and hot runner. The nozzles and manifold must be at room temperature (< 25 °C or < 77 °F) before the cavity plate is connected to the hot runner. Severe damage to the nozzle and cavity plate sealing diameters could result if the mold is still hot.

7. Slowly close the clamp to move the cavity plate into position. Make sure the wires in the wire channels are not pinched between the plates while closing.
8. Lock out and tag the machine and controller (if equipped).
9. Remove all safety latch bars.
10. Install safety latch bars between the cavity plate and hot runner on both sides of the assembly. A minimum of two safety latch bars are required.

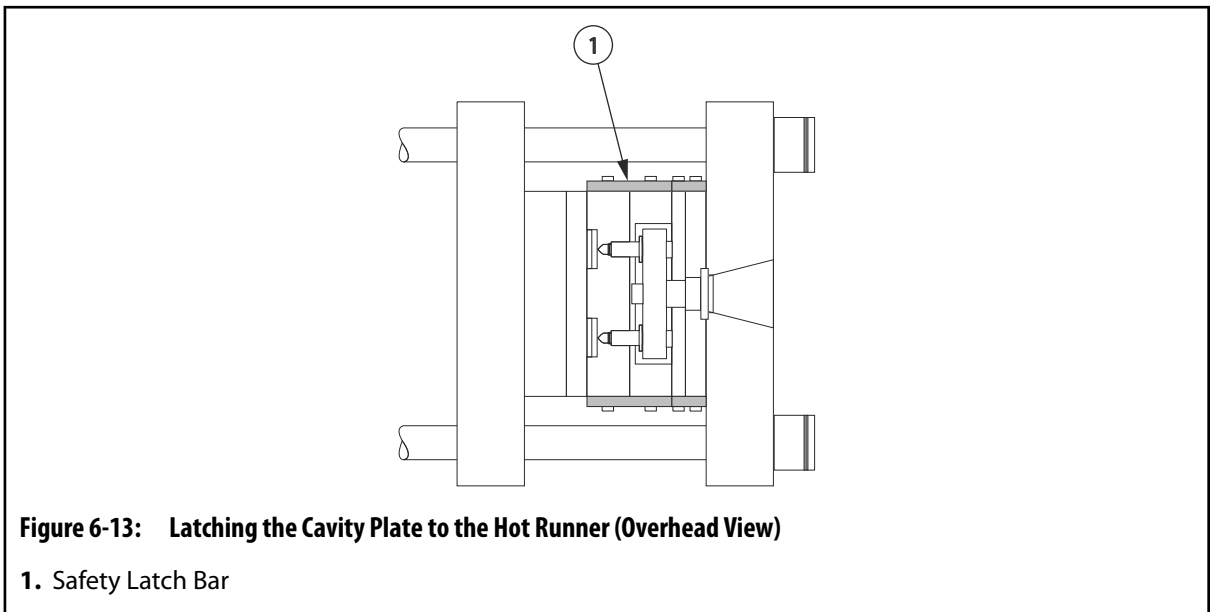

11. Remove all locks and tags.
12. Reduce the clamp opening and closing speed.
13. Slowly open the clamp to move the cavity plate away from the core plate.
14. Lock out and tag the machine and controller (if equipped).
15. Install the screws that secure the cavity plate to the hot runner and torque them to the specified value. Refer to the manufacturer's documentation for torque requirements.
16. Remove all safety latch bars.
17. Check the electrical circuit with an ohmmeter to make sure no wires were damaged during installation. Refer to the electrical schematic to identify each zone.

6.7 Removing and Installing the Backing Plate

The following procedures describe how to remove and install the backing plate.

6.7.1 Removing the Backing Plate

To remove the backing plate, do the following:

NOTE:

The following procedure requires the use of an overhead lifting device. Refer to [Section 4.1](#) for lifting and handling instructions.

1. Remove the hot runner from the machine. Refer to [Section 4.3](#) for more information.
2. Remove the locating ring.

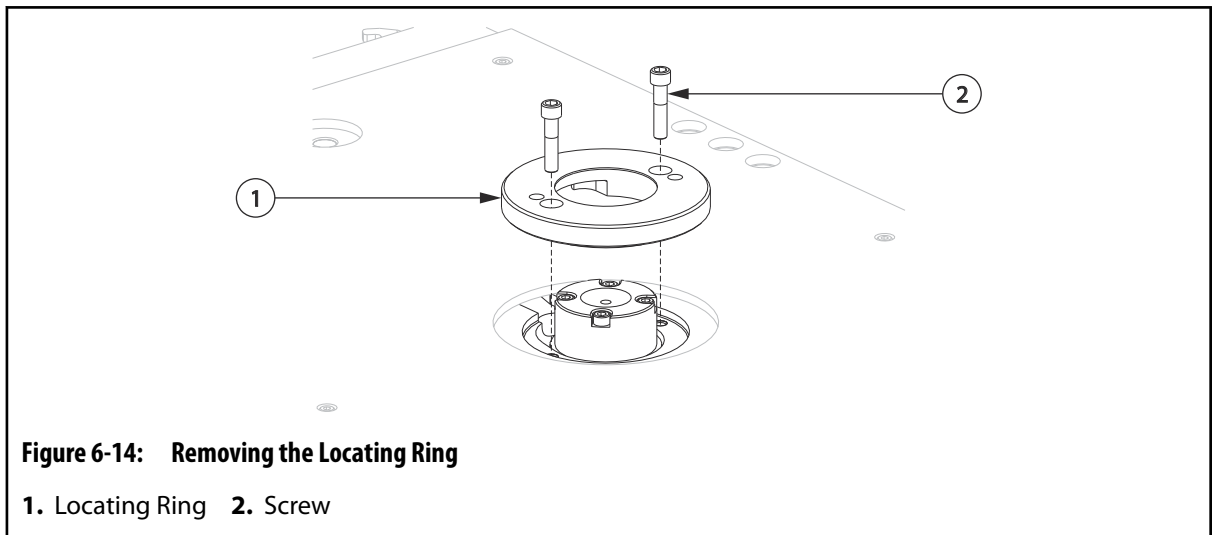

3. If equipped, remove the insulator board from the back of the backing plate.

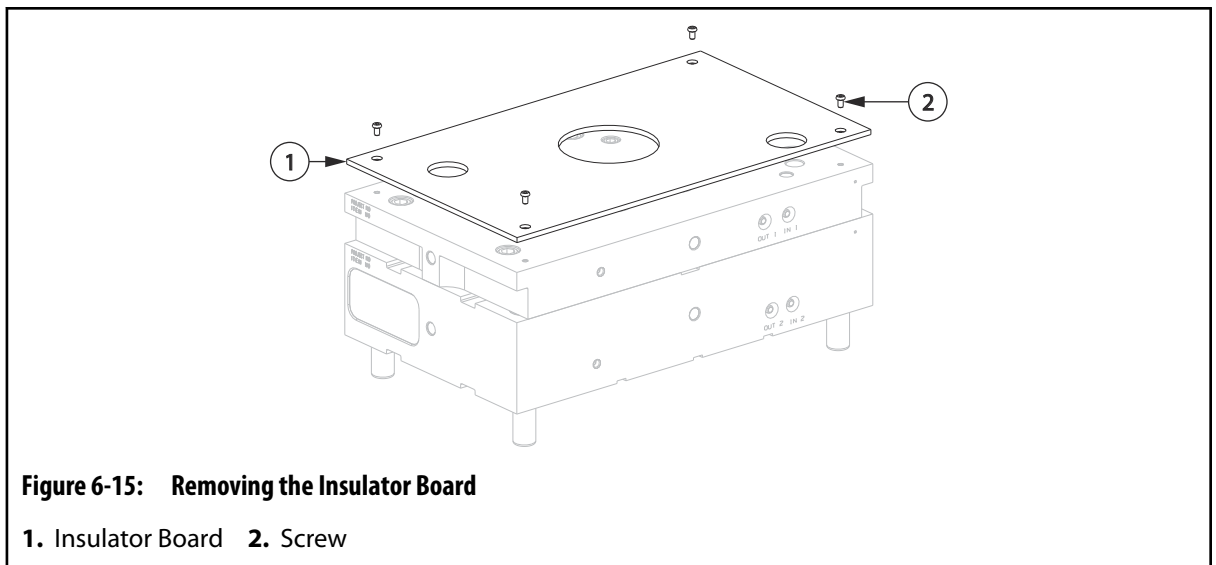

4. If the backing plate has wire grooves, do the following:
 - a. Disconnect the wires and thermocouples routed through the backing plate from the multi-pin connectors.
 - b. Remove the wires and thermocouples from the wire grooves.

5. Remove the screws that connect the backing plate to the manifold plate.

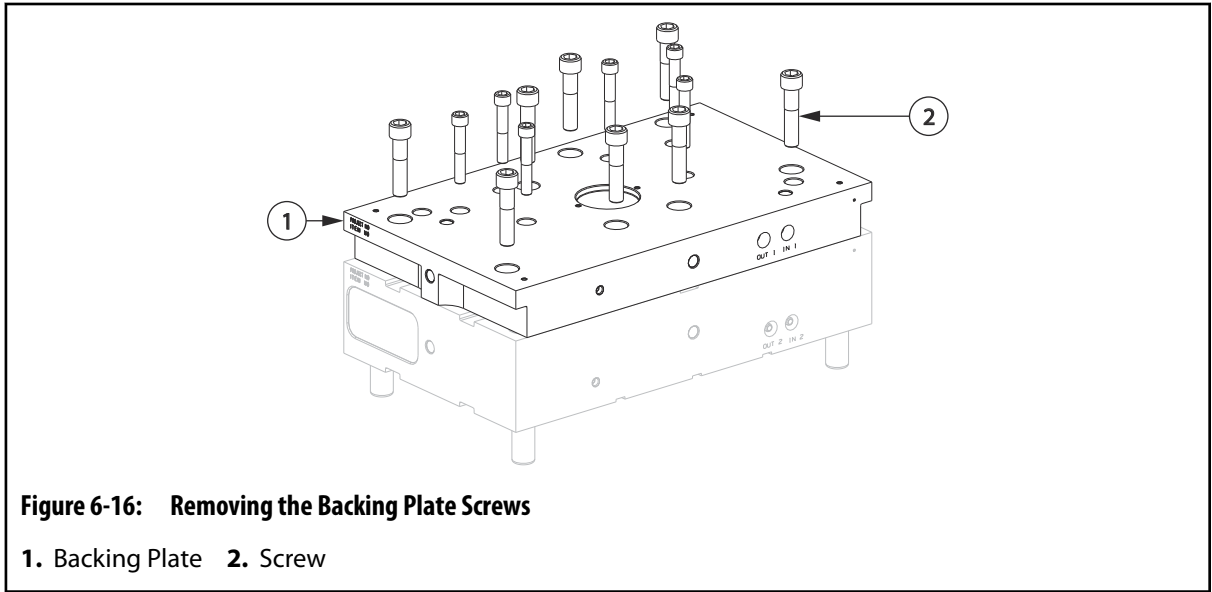

WARNING!

Crushing hazard – risk of death or serious injury. Inadequate lifting equipment could fail and cause death or serious injury. Make sure all lifting equipment is rated for the load and in safe operating condition.

6. Install hoist rings in the designated lifting points marked on the backing plate.
7. Attach an overhead lifting device to the hoist rings and lift the backing plate in stages. Use the pry slots between the manifold plate and backing plate to assist in separation.

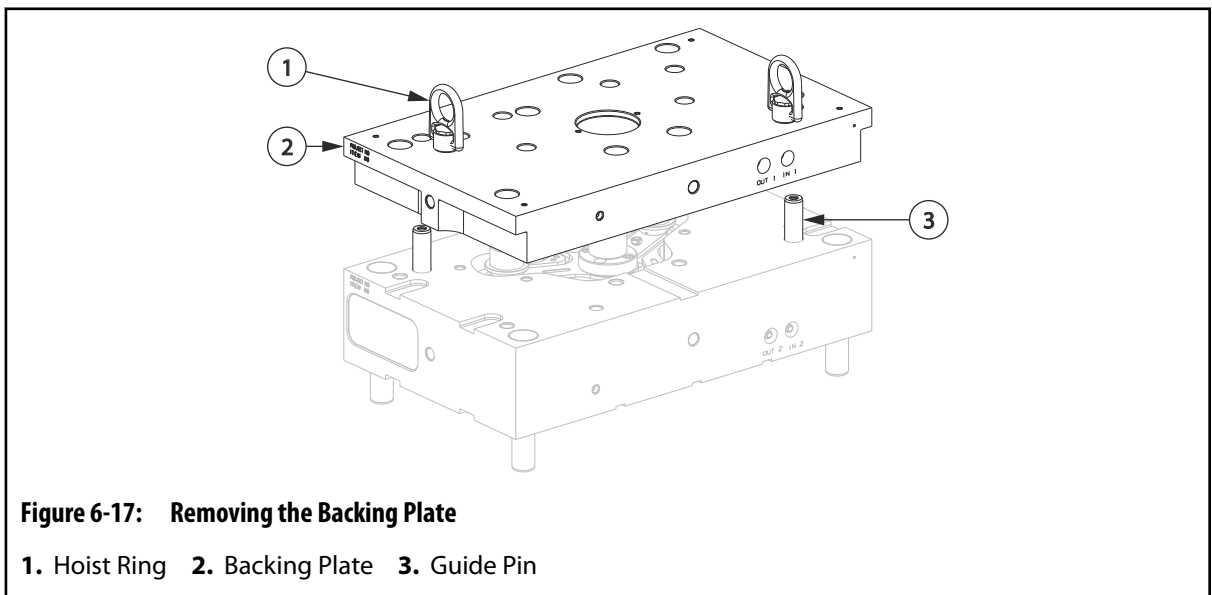

8. Moving the backing plate to a clean work area and set it on supports.

6.7.2 Installing the Backing Plate

To install the backing plate, do the following:

NOTE:

The following procedure requires the use of an overhead lifting device. Refer to [Section 4.1](#) for lifting and handling instructions.

1. Make sure the backing plate and manifold plate are clean and free of pry marks around the pry slots.
 2. Clean the backing plate and manifold plate mounting surfaces with a medium India stone (240 grit oilstone) as needed.
-



WARNING!

Crushing hazard – risk of death or serious injury. Inadequate lifting equipment can fail and cause death or serious injury. Make sure all lifting equipment is rated for the load and in safe operating condition.

3. Install hoist rings in the designated lifting points marked on the backing plate.
4. Attach an overhead lifting device to the hoist rings and lift the backing plate.
5. Slowly lower the backing plate onto the manifold plate. Make sure the guide pins align with the backing plate locating bores.

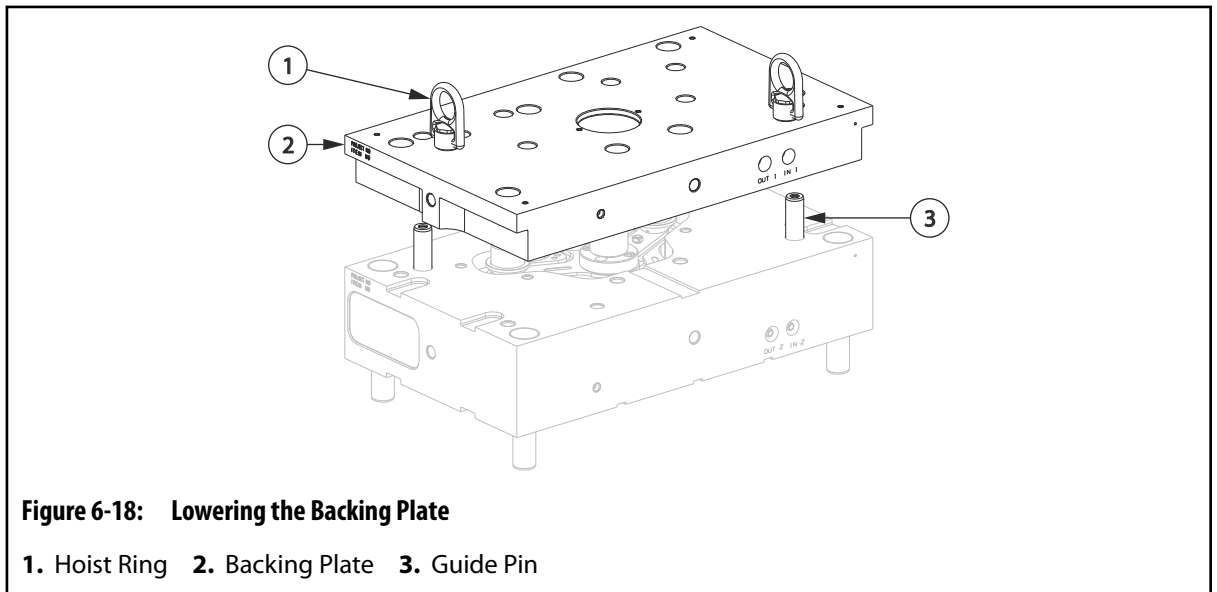

6. Disconnect the overhead lifting device and remove the hoist rings.
7. Install the screws that secure the backing plate to the manifold plate. Torque each screw to its specified value starting from the center and working outwards in a cross pattern. Refer to the assembly drawings for torque requirements.

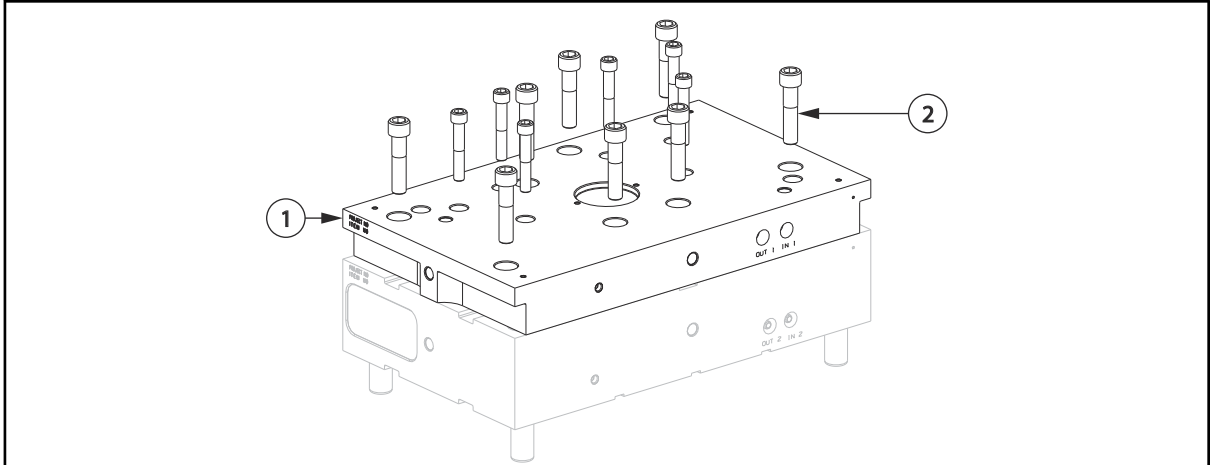

Figure 6-19: Installing the Backing Plate Screws

- 1. Backing Plate
- 2. Screw

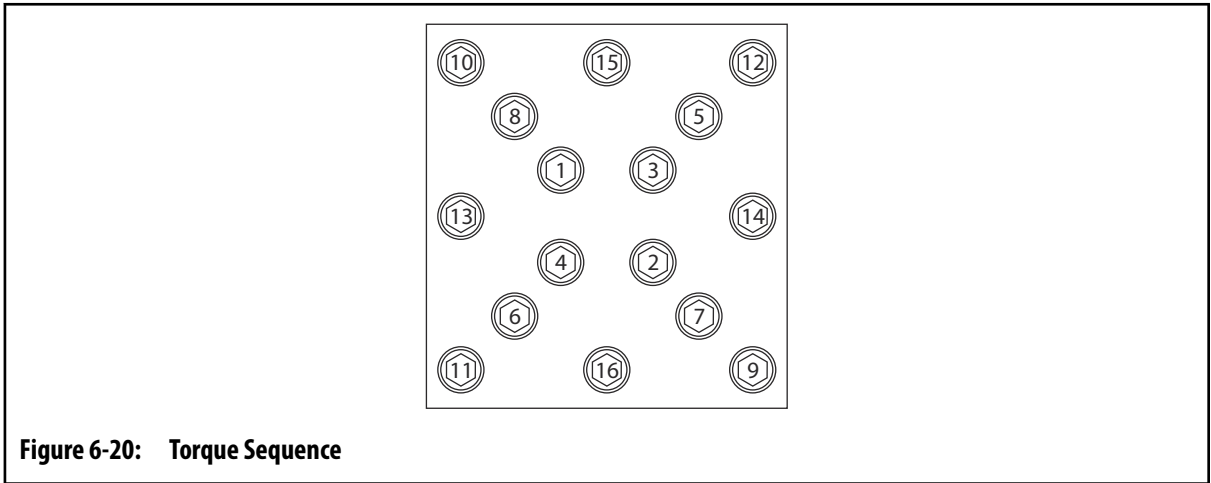
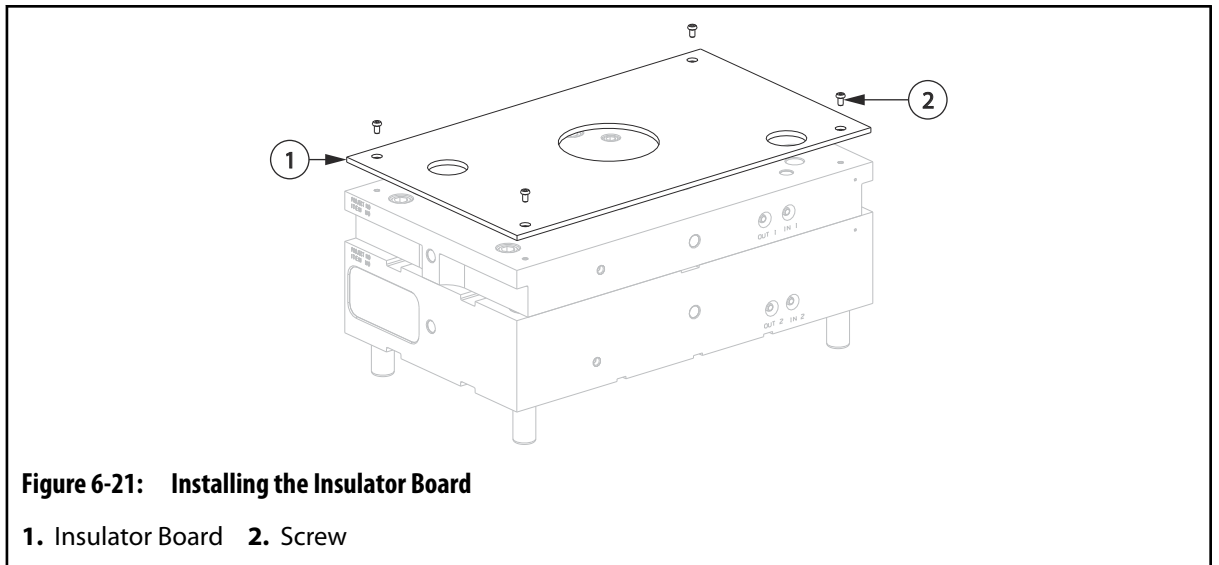
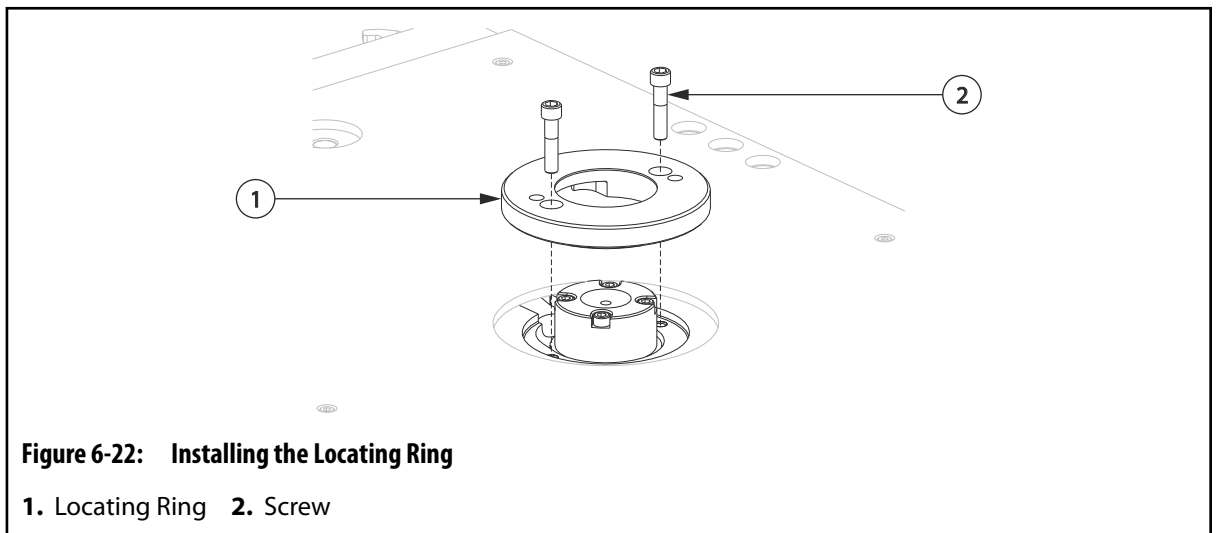

Figure 6-20: Torque Sequence

- 8. If equipped, install the insulator board and torque the screws to the specified value. Refer to the assembly drawings for torque requirements.



9. Install the locating ring.



6.8 Removing and Installing the Center Plate (If Equipped)

The following procedures describe how to remove and install the center plate.

6.8.1 Removing the Center Plate (If Equipped)

To remove the center plate, do the following:

NOTE:

The following procedure requires the use of an overhead lifting device. Refer to [Section 4.1](#) for lifting and handling instructions.

1. Remove the hot runner from the machine. Refer to [Section 4.3](#) for more information.
2. Remove the backing plate. Refer to [Section 6.7](#) for more information.
3. Remove the alignment dowels from the center plate.

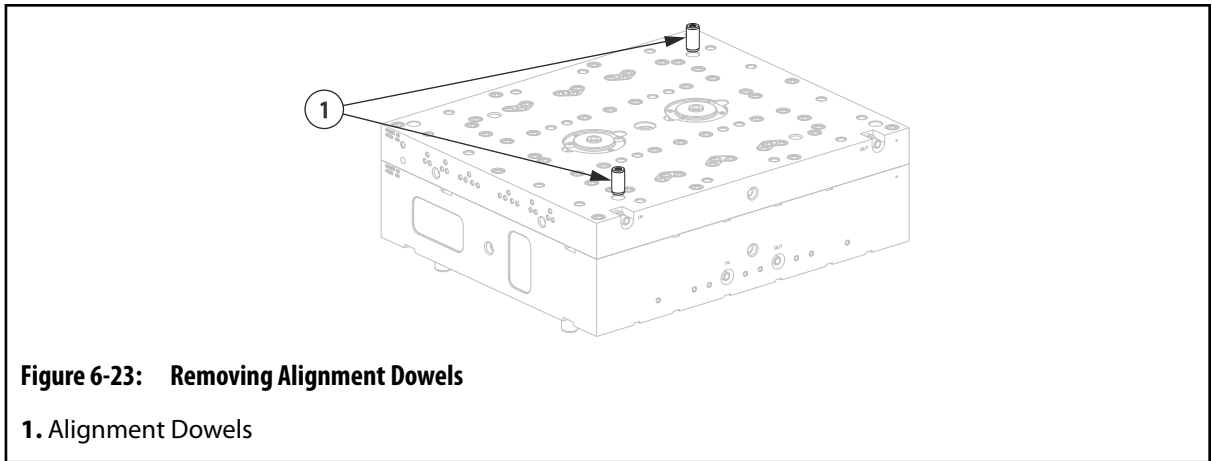

4. Remove the screws that secure the center plate to the manifold plate.

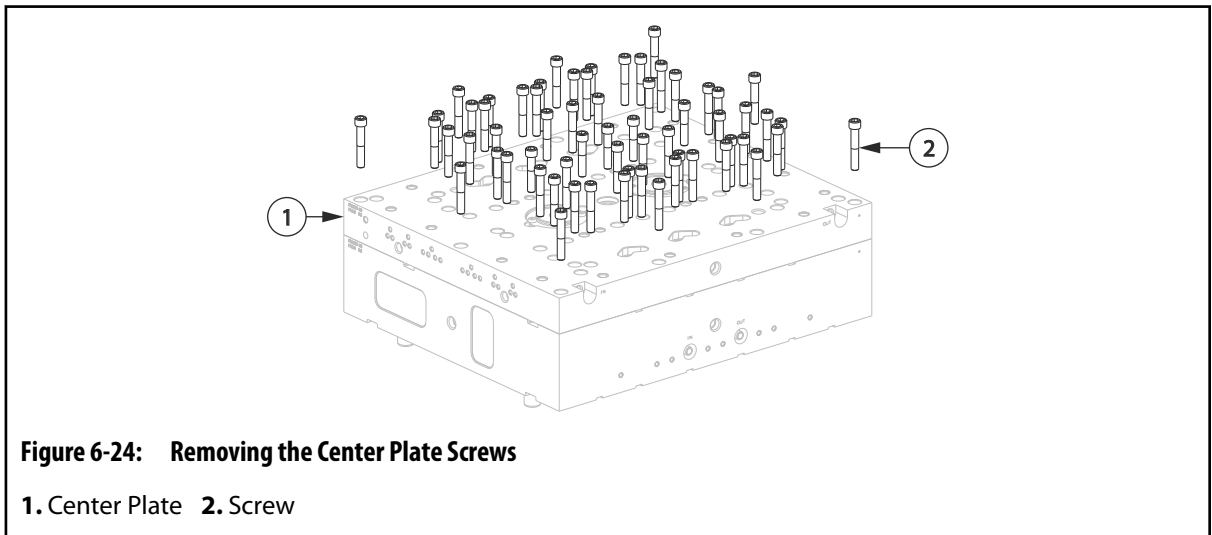

WARNING!

Crushing hazard – risk of death or serious injury. Inadequate lifting equipment could fail and cause death or serious injury. Make sure all lifting equipment is rated for the load and in safe operating condition.

5. Install hoist rings in the designated lifting points marked on the center plate.
6. Attach an overhead lifting device to the hoist rings and lift the center plate in stages. Use the pry slots between the manifold plate and center plate to assist in separation.

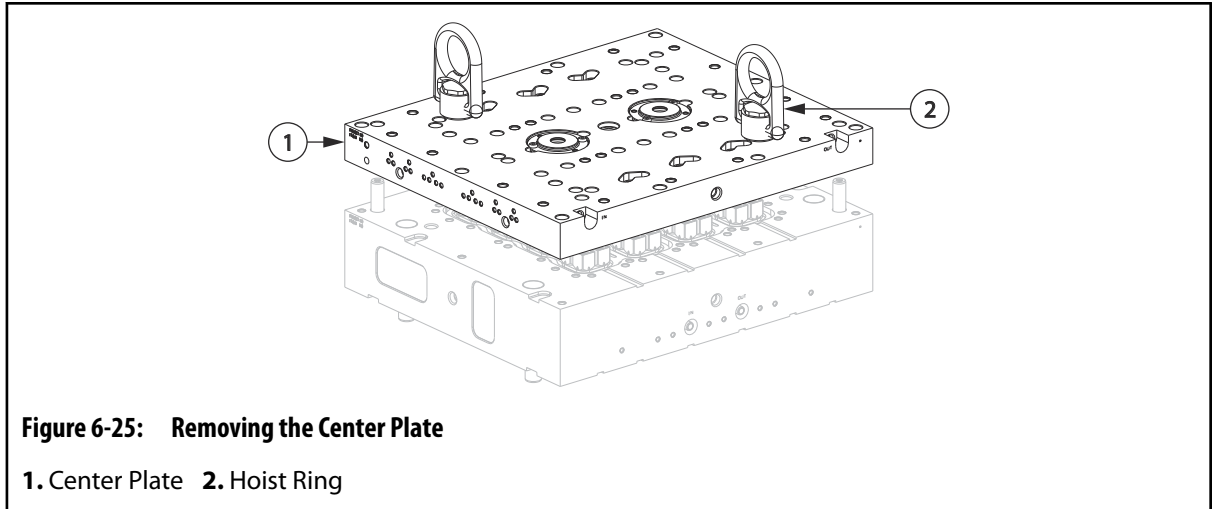

7. Move the center plate to a clean work area and set it on supports.

6.8.2 Installing the Center Plate (If Equipped)

To install the center plate, do the following:

NOTE:

The following procedure requires the use of an overhead lifting device. Refer to [Section 4.1](#) for lifting and handling instructions.

1. Make sure the manifold plate and center plate are clean and free of pry marks around the pry slots.
2. Clean the center plate surface with a medium India stone (240 grit oilstone) as needed.
3. Measure the dimensions of the backup pad bore depth and verify them with those in the assembly drawings.
4. Apply a static application grease to the guide pins in the manifold plate. Refer to [Section 3.5](#) for information about recommended lubricants.



WARNING!

Crushing hazard – risk of death or serious injury. Inadequate lifting equipment can fail and cause death or serious injury. Make sure all lifting equipment is rated for the load and in safe operating condition.

5. Install hoist rings in the designated lifting points marked on the center plate.

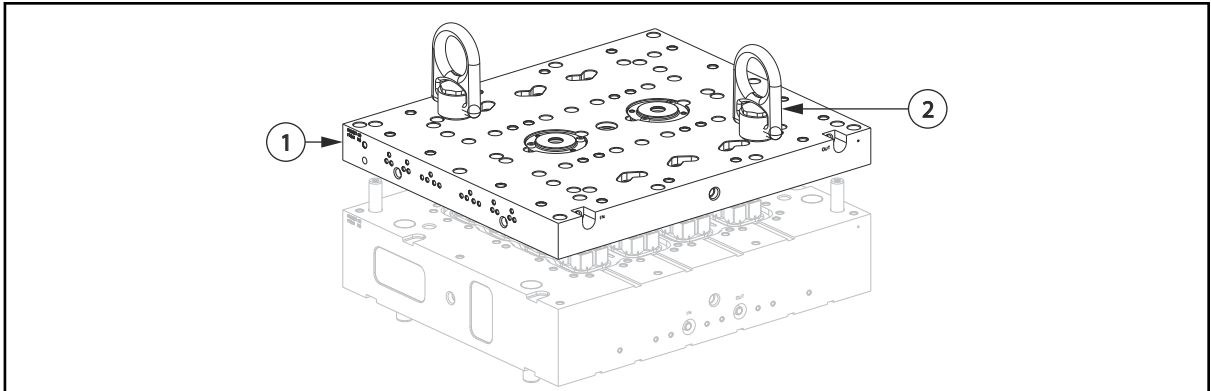

Figure 6-26: Installing the Center Plate

1. Center Plate 2. Hoist Ring

6. Attach an overhead lifting device to the hoist rings and lift the center plate.
7. Slowly lower the center plate onto the manifold plate. Make sure the guide pins align with the center plate locating bores.
8. Disconnect the overhead lifting device and remove the hoist rings.
9. Install the screws that secure the center plate to the manifold plate. Torque the screws to the specified value starting from the center and working outwards in a cross pattern. Refer to the assembly drawings for torque requirements.

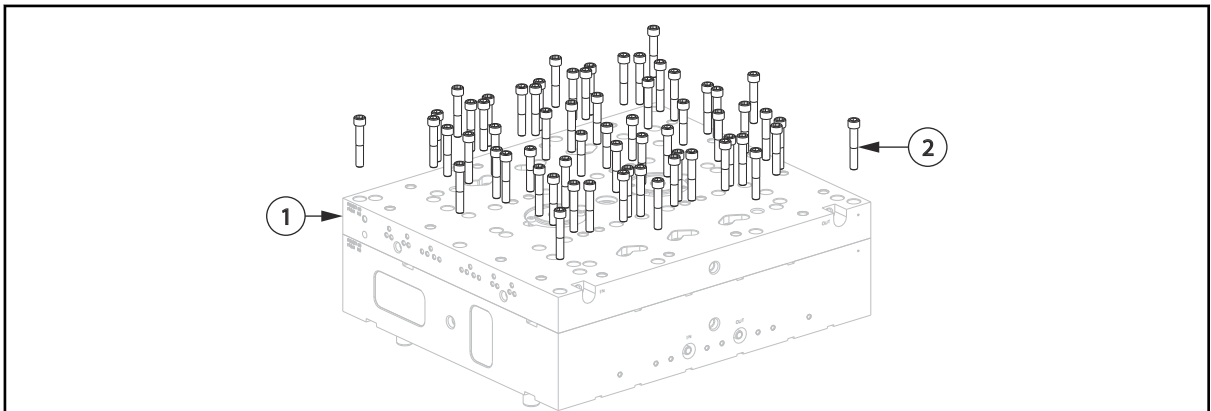

Figure 6-27: Installing the Center Plate Screws

1. Center Plate 2. Screw

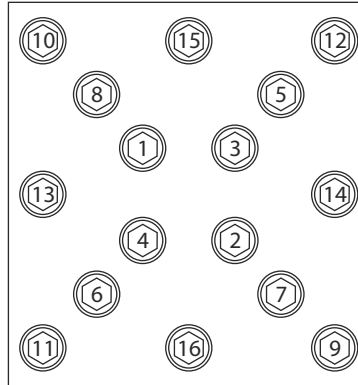

Figure 6-28: Torque Sequence

10. Install the alignment dowels.

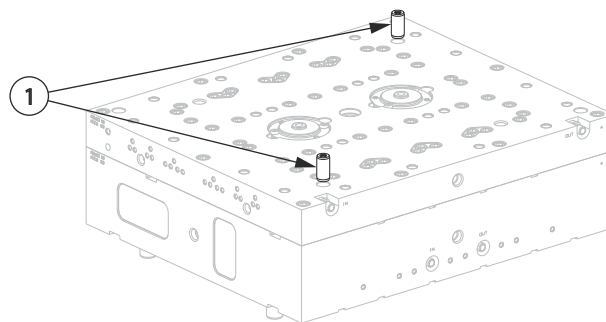

Figure 6-29: Installing the Alignment Dowels

1. Alignment Dowels

11. Install the backing plate. Refer to [Section 6.7.2](#) for more information.

6.9 Removing and Installing Manifolds

The following procedures describe how to remove, maintain and install the manifolds.

6.9.1 Removing a Cross Manifold (If Equipped)

To remove the cross manifold, do the following:

NOTE:

The following procedure requires the use of an overhead lifting device. Refer to [Section 4.1](#) for lifting and handling instructions.

- 1.** Remove the hot runner from the machine. Refer to [Section 4.3](#) for more information.
- 2.** Remove the backing plate and place it on a work bench with the cross manifold facing up. Refer to [Section 6.7](#) for more information.

3. Remove the screws that secure the cross manifold to the backing plate.

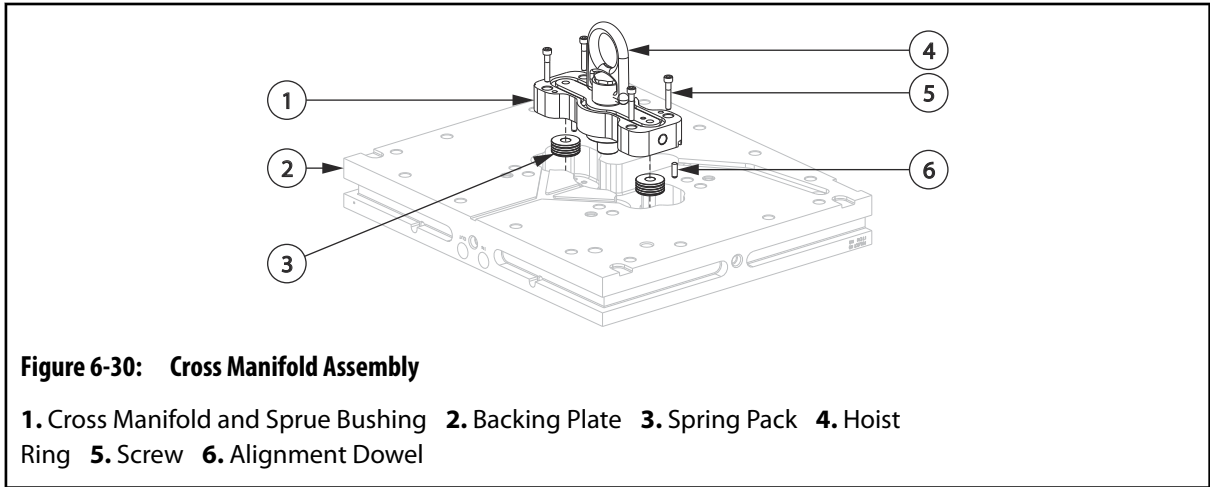

4. If the cross manifold has lifting points, do the following:



WARNING!

Crushing hazard – risk of death or serious injury. Inadequate lifting equipment could fail and cause death or serious injury. Make sure all lifting equipment is rated for the load and in safe operating condition.

- a. Install hoist rings in the designated lifting points marked on the cross manifold.
 - b. Attach an overhead lifting device to the hoist rings.
5. Lift the cross manifold and place it on a clean, flat work surface.



IMPORTANT!

There is no need to remove the sprue bushing from the manifold unless the following conditions occur:

- There is contaminated material in the sprue bushing melt channel
 - The material in the sprue bushing melt channel has been degraded by overheating
 - A complete disassembly is required for cleaning the manifold melt channels
6. If necessary, remove the sprue bushing. Refer to [Section 6.22](#) for more information.
 7. Remove the spring packs and alignment dowels.
 8. Inspect and clean the cross manifold. Refer to [Section 6.9.3](#) for more information.

6.9.2 Removing a Manifold

To remove a manifold, do the following:

NOTE:

The following procedure requires the use of an overhead lifting device. Refer to [Section 4.1](#) for lifting and handling instructions.

1. Remove the hot runner from the machine. Refer to [Section 4.3.2](#) for more information.
2. Remove the backing plate. Refer to [Section 6.7](#) for more information.

**IMPORTANT!**

There is no need to remove the sprue bushing (if equipped) from the manifold unless the following conditions occur:

- There is contaminated material in the sprue bushing melt channel
 - The material in the sprue bushing melt channel has been degraded by overheating
 - A complete disassembly is required for cleaning the manifold melt channels
3. If equipped, remove the sprue bushing or cross manifold.
 - For information about removing the sprue bushing, refer to [Section 6.21](#)
 - For information about removing the cross manifold, refer to [Section 6.9.1](#)
 4. If equipped, remove the center plate. Refer to [Section 6.8.1](#) for more information.
 5. If equipped, remove the transfer bushings. Refer to [Section 6.23.1](#) for more information.
 6. Remove the backup pads or cylinders.
 - For information about removing backup pads, refer to [Section 6.10](#)
 - For information about removing cylinders, refer to [Section 6.11](#)
 7. Disconnect all manifold heater and related thermocouple wires from the multi-pin connectors and wire channels.
 8. Remove the screws that secure the manifold to the manifold plate.

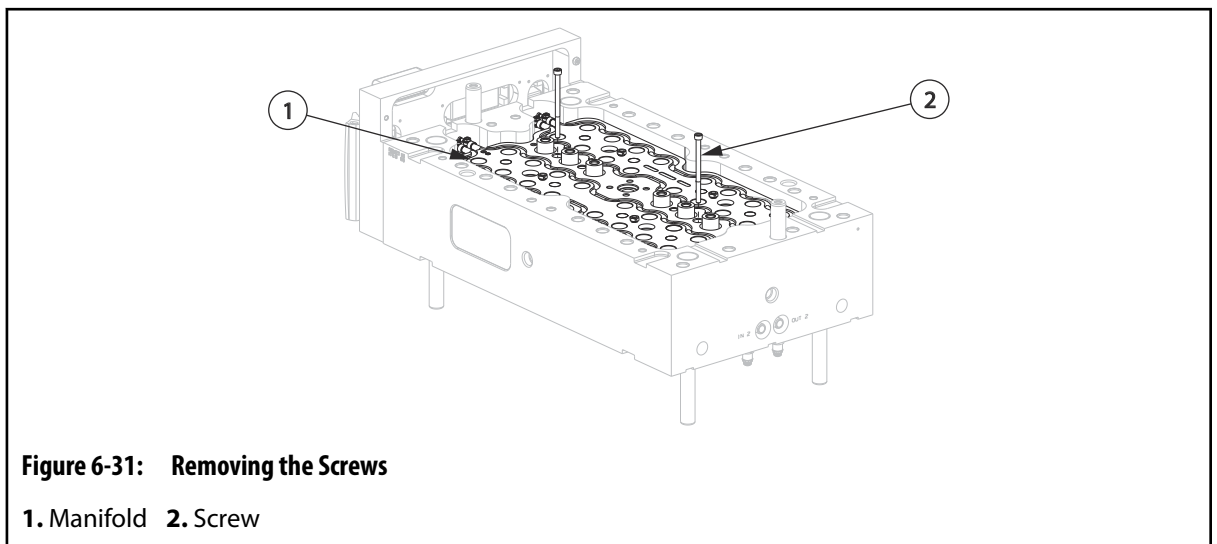

9. If the manifold has lifting points, do the following:



WARNING!

Crushing hazard – risk of death or serious injury. Inadequate lifting equipment can fail and could cause death or serious injury. Make sure all lifting equipment is rated for the load and in safe operating condition.

- a. Install hoist rings in the designated lifting points marked on the manifold.

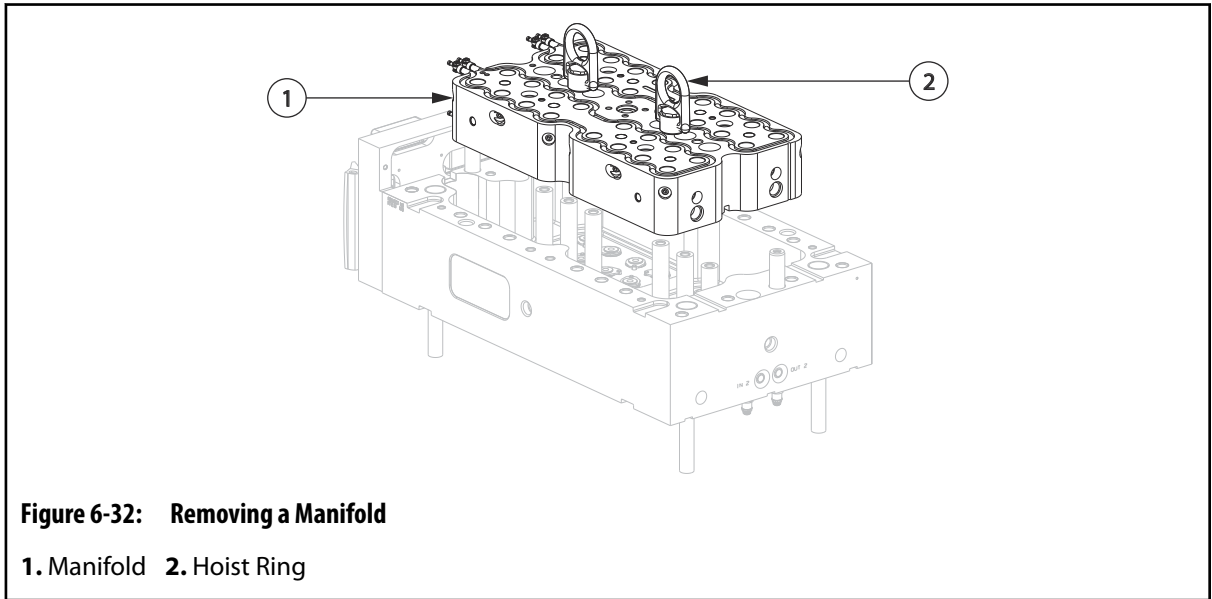

- b. Attach an overhead lifting device to the hoist rings.
10. Lift the manifold and place it on a clean, flat work surface.
 11. If hoist rings are installed, disconnect the overhead lifting device and remove the hoist rings.
 12. If necessary, remove the nozzle housings. Refer to [Section 6.16](#) for more information.
 13. Inspect and clean the manifold. Refer to [Section 6.9.3](#) for more information.

6.9.3 Inspecting and Cleaning Manifolds

To inspect and clean a manifold, do the following:

NOTE:

A fluidized bed cleaning process is recommended for cleaning manifolds and manifold components.

1. Clean the manifold in a fluidized bed. Refer to [Section 6.26.2](#) for more information.
However, if fluidized bed cleaning is unavailable, do the following:
 - a. Using brass scrapers, remove any resin left protruding from the manifold. Do not damage the sharp corners or sealing surfaces.
 - b. Clean the manifold bushing and seating surfaces using brass scrapers. Do not damage the sharp corners or sealing surfaces.

- c. Remove all resin from the backup pads and manifold pocket. Refer to [Section 6.27](#) for more information.
2. Clean the mating surfaces on the manifold with a medium India stone (240 grit oilstone). Do not scratch the manifold.
3. Make sure all contact surfaces on the manifold plate and manifold bushings are clean and free of resin, scratches, nicks or burrs.
4. Clean the mating surfaces on the manifold insulators with a medium India stone (240 grit oilstone). Do not scratch the manifold insulators.

CAUTION!

Mechanical hazard – risk of damage to the nozzle housings. Do not hone the back surface of the nozzle housing to remove nicks and burrs. The back surface is a precision made section of the housing with a contoured surface. Honing this section will cause the system to leak and void the leak proof guarantee for the hot runner.

-
5. Inspect the nozzle housings. Make sure they are free of nicks, burrs and any resin, especially in the melt channels. If the sealing surfaces are damaged in any way, replace the nozzle housings.
 6. Make sure the manifolds are clean and flat.

NOTE:

Use only Husky recommended high temperature power and thermocouple wire.

NOTE:

Refer to the electrical schematic when replacing wiring.

-
7. Check all manifold, heater and thermocouple wiring. Replace as necessary.

6.9.4 Installing a Manifold

To install a manifold, do the following:

NOTE:

The following procedure requires the use of an overhead lifting device. Refer to [Section 4.1](#) for lifting and handling instructions.

-
1. Replace the manifold bushings as necessary. Refer to [Section 6.20](#) for more information.
 2. Install the locating insulator, manifold locating dowel(s) and nozzle locating dowels into the manifold plate pocket.

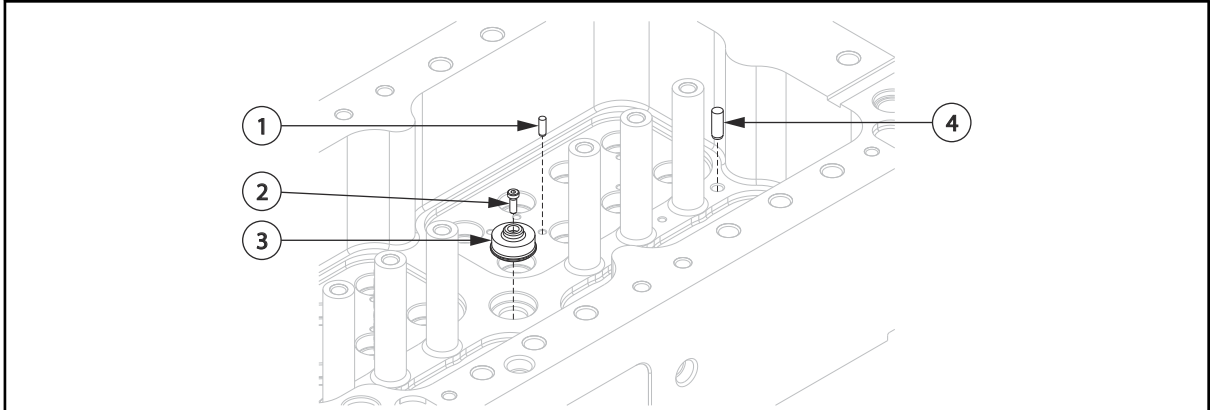

Figure 6-33: Assembling the Manifold Plate (Typical)

1. Nozzle Locating Dowel 2. Screw 3. Locating Insulator 4. Manifold Locating Dowel

- 3. If removed previously, install the nozzle housings in the manifold plate. Refer to [Section 6.16](#) for more information.
- 4. If the manifold has lifting points, do the following:



WARNING!

Crushing hazard – risk of death or serious injury. Inadequate lifting equipment can fail and could cause death or serious injury. Make sure all lifting equipment is rated for the load and in safe operating condition.

- a. Install hoist rings in the designated lifting points marked on the manifold.

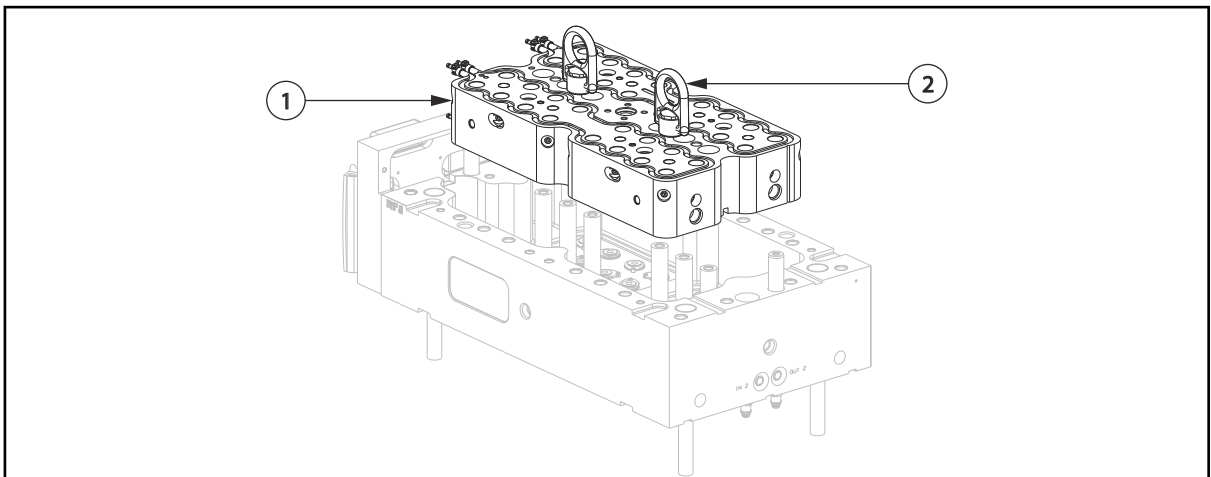

Figure 6-34: Installing a Manifold

1. Manifold 2. Hoist Ring

- b. Attach an overhead lifting device to the hoist rings.
5. Lift the manifold over the manifold plate pocket.

6. Lower the manifold into position onto the locating insulator and locating dowel. Adjust the manifold to engage the locating features.
7. If hoist rings are installed, disconnect the overhead lifting device and remove the hoist rings.
8. Apply a thread-locking fluid to the threads of the screws that secure the manifold to the manifold plate. Refer to [Section 3.5](#) for information about recommended lubricants.

CAUTION!

Mechanical hazard – risk of damage to the hot runner. Screws used to secure the manifolds must remain loose until the preload is measured. Overtightening the screws could over-extend the nozzle housings or damage components under the manifold that are not properly seated.

9. Install and hand tighten the screws. Do not apply torque.

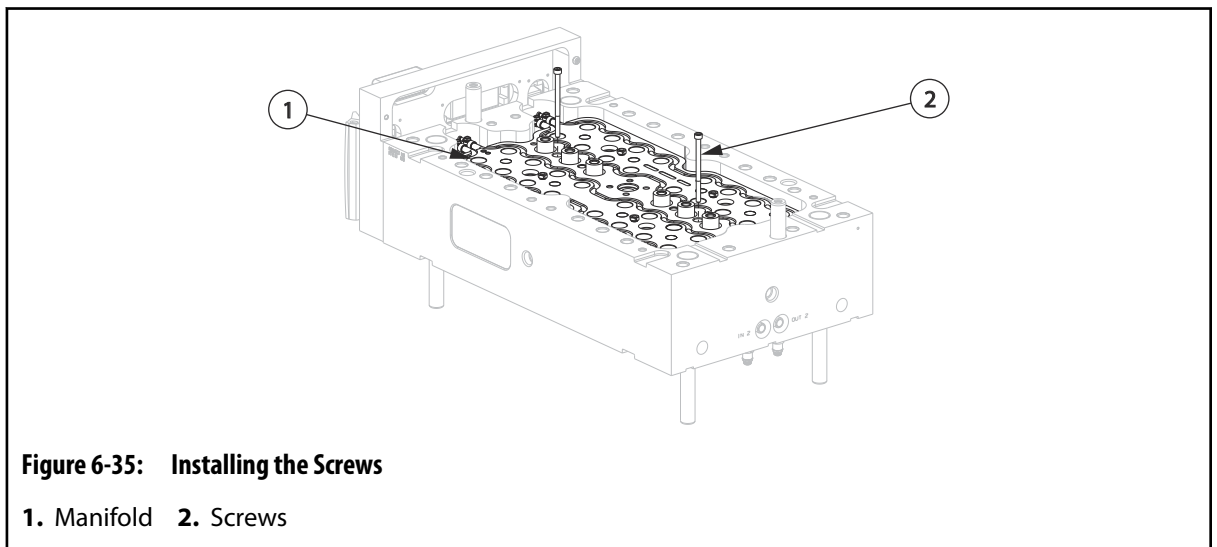

10. Turn the screws counter-clockwise 1/4 turn.
11. Measure the preload for the manifold. Refer to [Section 6.4](#) for more information.



IMPORTANT!

All wiring near the manifold heater must be either a high temperature braid or sleeved using high temperature sleeving.

12. Route the manifold heater and thermocouple wires through the exit channels at the top of the manifold plate.
13. Label each wire with the heater zone number. Refer to the electrical schematic for the zone number.
14. Crimp the wire ends and connect the wires to the appropriate multi-pin connectors. Refer to the electrical schematic for more information.
15. Install the backup pads or cylinders on the manifold.
 - For information about installing backup pads, refer to [Section 6.10](#).
 - For information about installing cylinders, refer to [Section 6.11](#).

16. If equipped, install the transfer bushings. Refer to [Section 6.23.2](#) for more information.
17. If equipped, install the center plate. Refer to [Section 6.8](#) for more information.
18. If equipped, install the sprue bushing or cross manifold.
 - For information about installing the sprue bushing, refer to [Section 6.21](#).
 - For information about installing the cross manifold, refer to [Section 6.9.5](#).
19. Install the backing plate. Refer to [Section 6.7](#) for more information.
20. Install the hot runner in the machine. Refer to [Section 4.3](#) for more information.

6.9.5 Installing a Cross Manifold (If Equipped)

To install the cross manifold, do the following:

NOTE:

The following procedure requires the use of an overhead lifting device. Refer to [Section 4.1](#) for lifting and handling instructions.

1. Make sure the manifolds are installed. Refer to [Section 6.9.4](#) for more information.
2. Insert the spring packs and alignment dowels into the cross manifold pocket in the backing plate.
3. Install the sprue bushing. Refer to [Section 6.22.2](#) for more information.
4. If the cross manifold has lifting points, do the following:



WARNING!

Crushing hazard – risk of death or serious injury. Inadequate lifting equipment can fail and cause death or serious injury. Make sure all lifting equipment is rated for the load and in safe operating condition.

- a. Install hoist rings in the designated lifting points marked on the cross manifold.

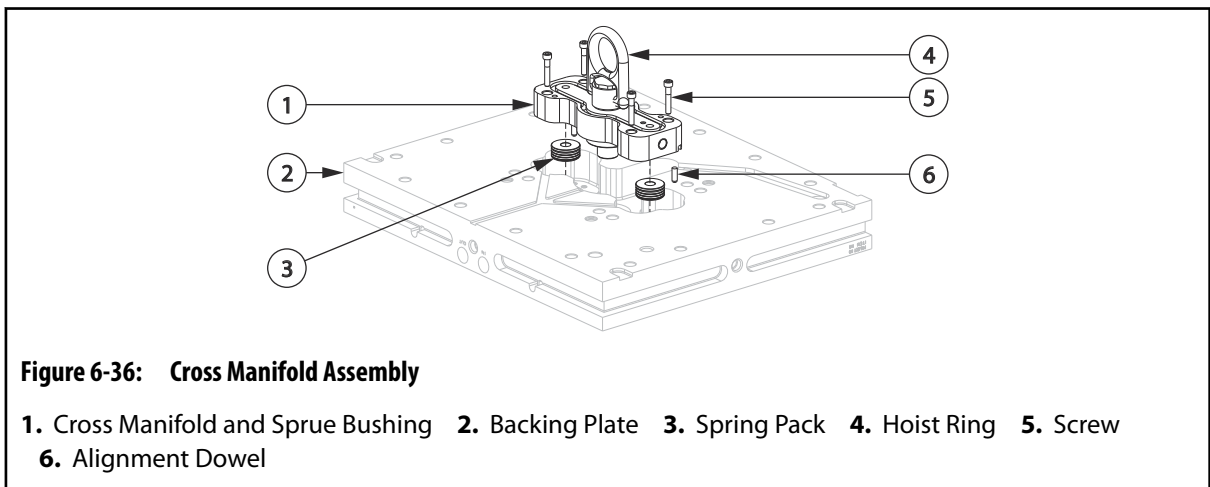

- b. Attach an overhead lifting device to the hoist rings.

5. Lift the cross manifold and sprue bushing over the backing plate pocket.
6. Lower the cross manifold onto the spring packs and alignment dowels. Adjust the cross manifold to engage the locating features.
7. If hoist rings are installed, disconnect the overhead lifting device and remove the hoist rings.
8. Apply a thread-locking fluid to the threads of the screws that secure the cross manifold to the backing plate. Refer to [Section 3.5](#) for information about recommended lubricants.

CAUTION!

Mechanical hazard – risk of damage to the hot runner. Screws used to secure the manifolds must remain loose until the preload is measured. Overtightening the screws could over-extend the nozzle housings or damage components under the manifold that are not properly seated.

-
9. Install and hand tighten the screws. Do not apply torque.
 10. Turn the screws counter-clockwise 1/4 turn.
 11. Measure the preload for the cross manifold. Refer to [Section 6.4](#) for more information.



IMPORTANT!

All wiring near the manifold heater must be either a high temperature braid or sleeved using high temperature sleeving.

-
12. Route the cross manifold heater and thermocouple wires through the wire channels in the backing plate. Make sure all wiring is properly retained in the wire channels using wire clips.
 13. Label each wire with the heater zone number. Refer to the electrical schematic for the zone number.
 14. Crimp the wire ends and connect the wires to the appropriate multi-pin connectors. Refer to the electrical schematic for more information.
 15. Test each cross manifold heater. Refer to [Section 6.5](#) for more information.
 16. Install the backing plate. Refer to [Section 6.7.2](#) for more information.

6.10 Removing and Installing VG-LX and EX Backup Pads

The following procedures describe how to remove and install the backup pads from the manifold. Backup pads are specific to VG-LX/EX hot runners.

6.10.1 Removing the VG-LX and EX Backup Pads

To remove the backup pads, do the following:

1. Remove the hot runner from the machine. Refer to [Section 4.3](#) for more information.
2. Remove the backing plate. Refer to [Section 6.7](#) for more information.
3. If equipped, remove the center plate. Refer to [Section 6.8](#) for more information.

4. Remove the valve stem assemblies. Refer to [Section 6.12](#) for more information.
5. For each backup pad, do the following:
 - a. Remove the clip ring.

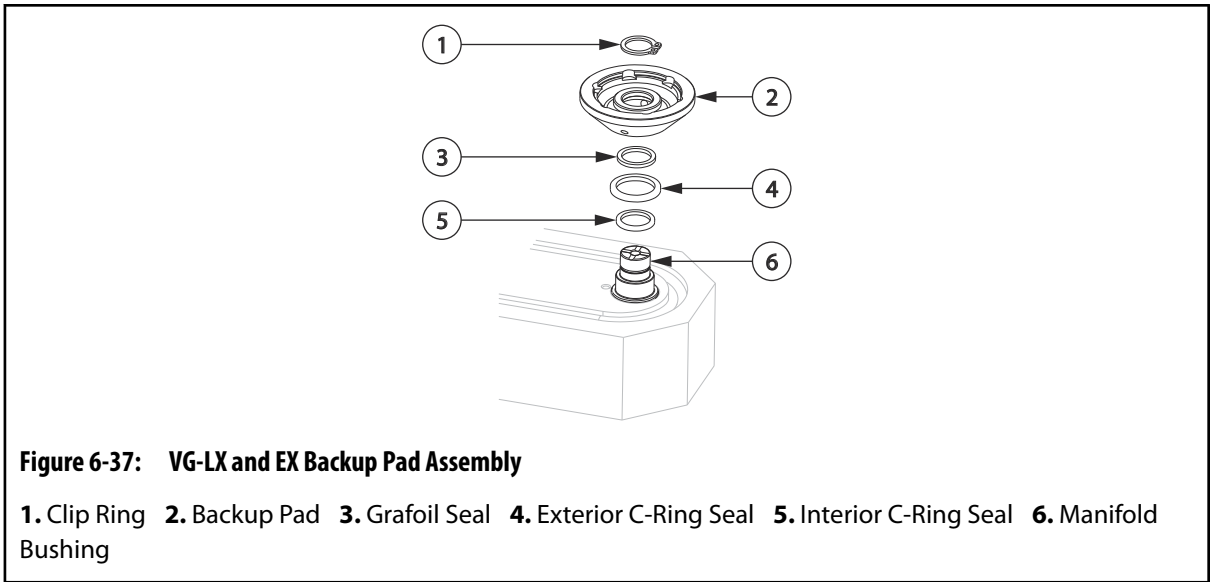

- b. Install the backup pad removal tool by aligning the screw with the manifold bushing and installing the pull posts. Refer to [Section 1.8](#) for a list of special Husky tools and order numbers.

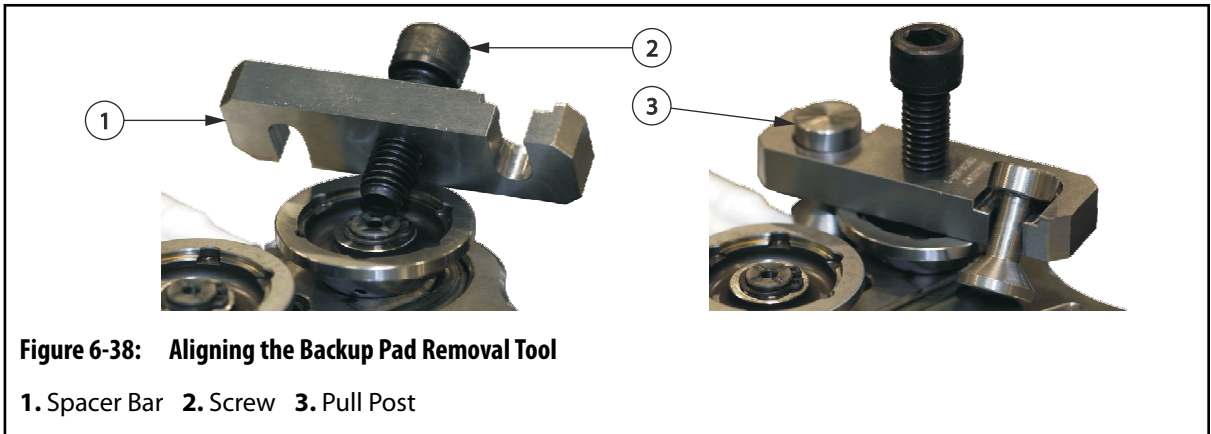

- c. Turn the screw on the backup pad removal tool clockwise to remove the backup pad.
 - d. Discard the C-ring seals and Grafoil seal.
 - e. Remove any resin deposits inside the backup pad.

6.10.2 Installing the VG-LX and EX Backup Pads

To install the backup pads, do the following:

1. For each backup pad, do the following:
 - a. Install new interior and exterior C-ring seals over the manifold bushing.

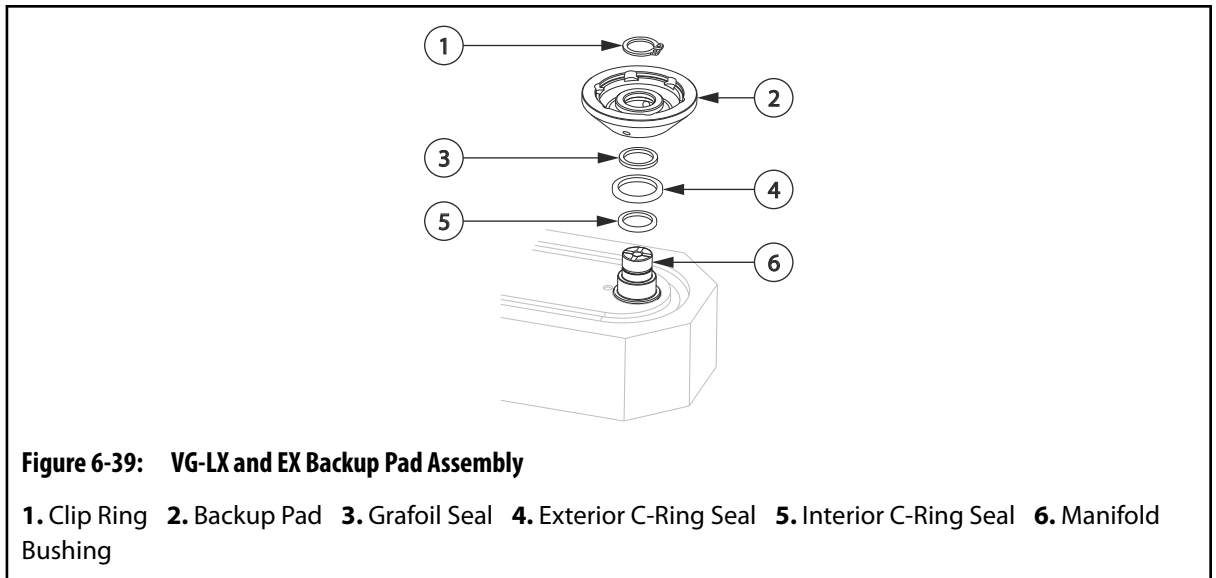

- b. Install a new Grafoil seal over the manifold bushing.
 - c. Install the backup pad. Make sure the backup pad contacts the metal O-ring seal.
 - d. Install the clip ring.
2. Measure the preload for the manifold. Refer to [Section 6.4](#) for more information.
3. Install the valve stem assemblies. Refer to [Section 6.12.4](#) for more information.
4. If equipped, install the center plate. Refer to [Section 6.8](#) for more information.
5. Install the backing plate. Refer to [Section 6.7](#) for more information.
6. Install the hot runner in the machine. Refer to [Section 4.3](#) for more information.

6.11 Removing and Installing VG-SX Cylinders

The following procedures describe how to remove and install the cylinders from the manifold. Cylinders are specific to VG-SX hot runners.

6.11.1 Removing Cylinders

To remove the cylinders, do the following:

1. Remove the hot runner from the machine. Refer to [Section 4.3](#) for more information.
2. Remove the backing plate. Refer to [Section 6.7](#) for more information.
3. If equipped, remove the center plate. Refer to [Section 6.8](#) for more information.
4. Remove the valve stem assemblies. Refer to [Section 6.12](#) for more information.
5. For each cylinder, do the following:
 - a. Remove any resin deposits on the cylinder.

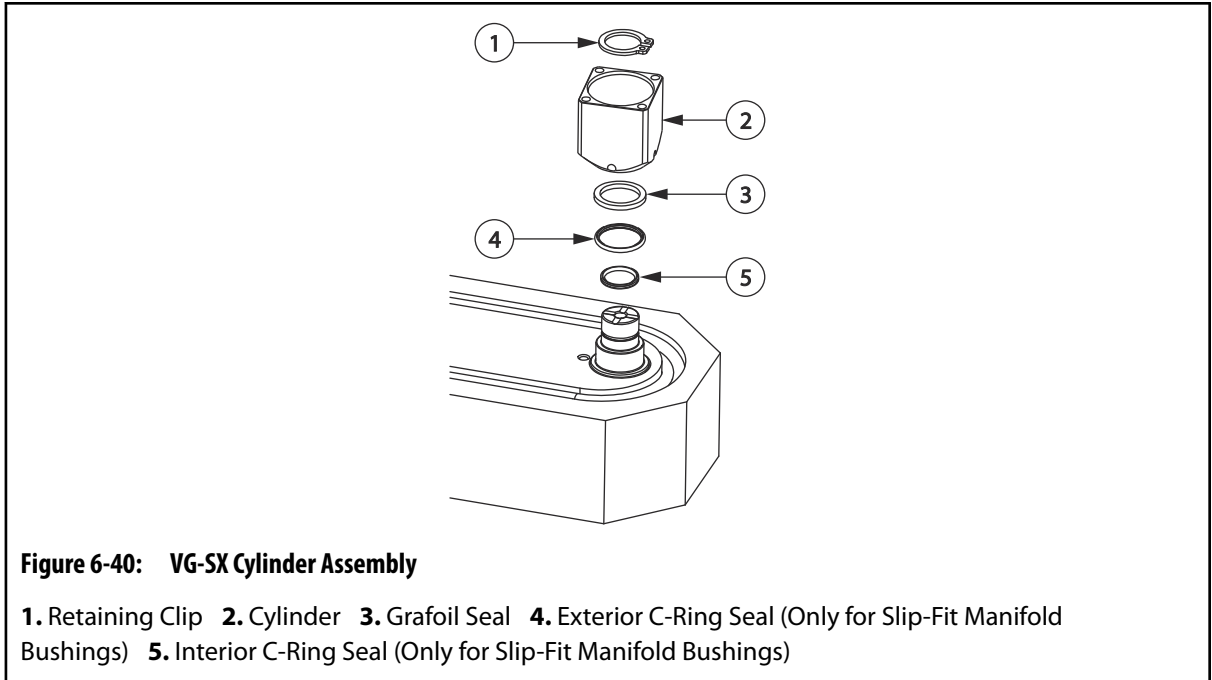

- b. Remove the retaining clips from each cylinder.
- c. Remove the cylinder.
- d. Discard the Grafoil seal.
- e. If equipped, discard the exterior and interior C-ring seals.

6.11.2 Installing Cylinders

To install a cylinder, do the following:

- 1. For each cylinder, do the following:
 - a. Clean or replace the cylinders as needed.

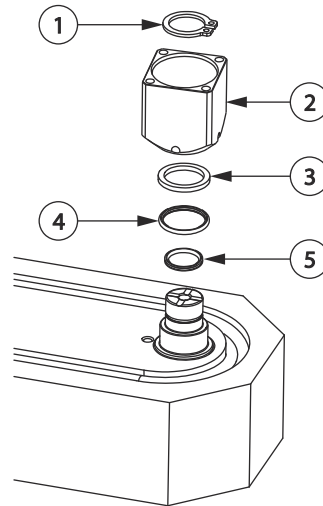

Figure 6-41: VG-SX Cylinder Assembly

1. Retaining Clip 2. Cylinder 3. Grafoil Seal 4. Exterior C-Ring Seal (Only for Slip-Fit Manifold Bushings) 5. Interior C-Ring Seal (Only for Slip-Fit Manifold Bushings)

- b. Inspect the retaining clip and replace it if it is damaged or worn.

NOTE:

Interior and exterior C-ring seals are only required when slip-fit manifold bushings are installed.

- c. Clean or replace the cylinder as needed.
 - d. Place a new Grafoil seal over the manifold bushing.
 - e. For slip-fit manifold bushings only, do the following:
 - i. Place a new interior C-ring seal over the manifold bushing
 - ii. Coat the bottom of the cylinder with a high temperature lubricant and insert a new exterior C-ring seal.
 - f. Align the cylinder with the locating dowel and press it onto the manifold until the cylinder is fully seated.
 - g. Install the retaining clip into the groove at the end of the manifold bushing.
2. Measure the preload for the manifold. Refer to [Section 6.4](#) for more information.
 3. Install the valve stem assemblies. Refer to [Section 6.12](#) for more information.
 4. If equipped, install the center plate. Refer to [Section 6.8](#) for more information.
 5. Install the backing plate. Refer to [Section 6.7](#) for more information.
 6. Install the hot runner in the machine. Refer to [Section 4.3](#) for more information.

6.12 Removing and Installing Valve Stems

The following procedures describe how to remove and install the valve stems.

6.12.1 Removing the Valve Stems for U350 and U500 VG-SX Systems

Valve stems can be removed when the hot runner is cold or hot, with each method offering its own advantages and disadvantages.

Cold		Hot	
Advantage	Disadvantage	Advantage	Disadvantage
<ul style="list-style-type: none"> Fast removal reduces down time Easy to clean No danger from heat 	<ul style="list-style-type: none"> Valve stem may break More difficult to remove valve stem 	<ul style="list-style-type: none"> Reduces the risk of valve stems breaking Valve stems are easy to remove 	<ul style="list-style-type: none"> Slow, increased down time Difficult to clean Danger from heat

To remove valve stems from the hot runner, do the following:

NOTE:

This procedure can be performed in the machine or on a work bench.

1. Remove the backing plate. Refer to [Section 6.7](#) for more information.
2. If equipped, remove the center plate. Refer to [Section 6.8](#) for more information.
3. If the valve stems will be removed while the hot runner is cold, proceed to [step 4](#). However, if the valve stems will be removed while the hot runner is hot, do the following:
 - a. Reconnect any thermocouples that were disconnected during disassembly.
 - b. Connect the hot runner to a controller.
 - c. Turn on the controller.



DANGER!

Electrocution hazard – risk of death, serious injury and/or damage to the hot runner. Do not turn on the heaters if water has leaked into the hot runner. If water has leaked into the hot runner, the hot runner must be completely disassembled, dried and assembled before the heaters are turned on.



WARNING!

Hot resin spray hazard – risk of serious injury. Hot resin may unexpectedly spray from the nozzle tips while the hot runner is reaching operating temperature. To avoid serious burns, wear personal protective equipment consisting of a heat-resistant coat, heat-resistant gloves and a full face shield over safety glasses. Use adequate ventilation for fumes.

**WARNING!**

Burn hazard – risk of serious injury. Hot runner components stay hot for long periods of time after heaters have been turned off. Wear personal protective equipment when working near the hot runner and place a warning sign in the area before leaving the hot runner unattended.

- d. Increase the temperature of the hot runner to a temperature high enough to soften the resin in the melt channels.

NOTE:

The Vicat Softening Temperature for the resin type is recommended. Refer to the resin supplier's documentation for more information.

**WARNING!**

Electrocution hazard - risk of death or serious injury. Complete the lockout/tagout procedure of the electrical power source before disconnecting the electrical connectors.

- e. Lock out and tag the electrical power source.

**IMPORTANT!**

Do not allow the nozzle tips to overheat or degraded material will have to be cleaned out of the nozzle housing before a new nozzle tip can be installed.

- f. Disconnect the controller.
4. For each valve stem to be removed, do the following:

NOTE:

Refer to [Section 1.8](#) for a list of special tools and part numbers.

- a. From the valve stem removal tool assembly, place the valve stem removal tool base on top of the cylinder.

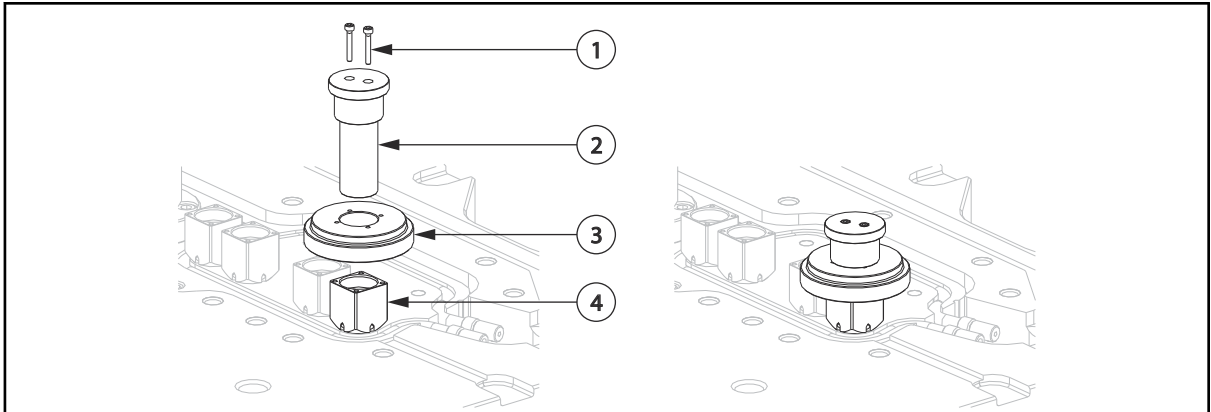

Figure 6-42: Valve Stem Removal Tool Base and Piston Head Adapter Assembly

1. Screw 2. Piston Head Adapter 3. Valve Stem Removal Tool Base 4. Piston

- b. Insert the piston head through the valve stem removal base into the piston.
- c. Install screws to secure the piston head to the piston.

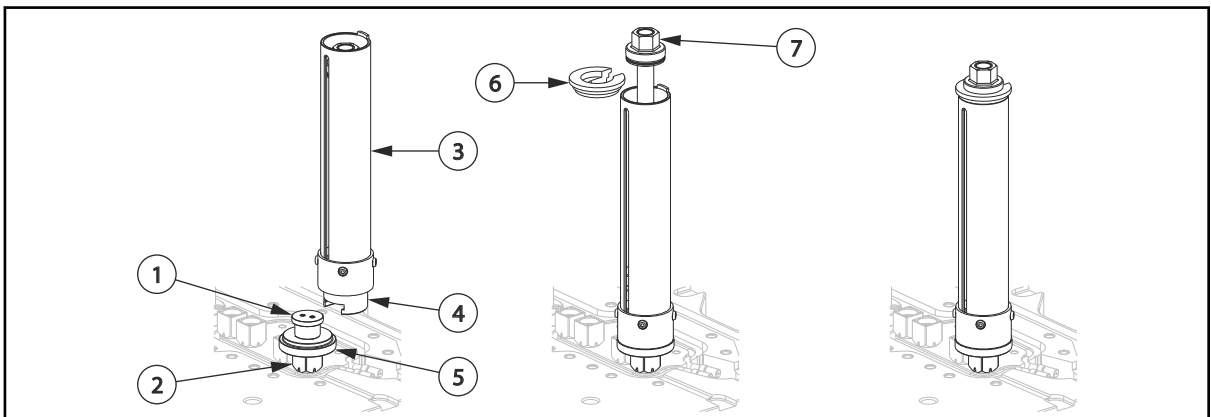

Figure 6-43: Valve Stem Removal Tool Assembly

1. Piston Head Adapter 2. Cylinder 3. Sleeve 4. Interface Tool 5. Valve Stem Removal Tool Base 6. Cap 7. Nut

- d. Slide the interface tool onto the piston head adapter.
- e. Lower the sleeve and insert the cap beneath the thrust washers.
- f. Hold the valve stem removal tool in place and rotate the top nut clockwise until it is tight.

CAUTION!

Mechanical hazard – risk of damage to the equipment. Be careful not to bend the valve stem when removing it. Bent valve stems cannot be re-used.

CAUTION!

Mechanical hazard – risk of damage to the equipment. If the valve stem and piston do not pull out easily, the valve stem may have seized in the manifold bushing. If this is the case, remove the manifold bushing from the manifold and remove the valve stem. Contact Husky for more information.

- g. Using a wrench, rotate the nut on the valve stem removal tool clockwise to remove the valve stem assembly.

NOTE:

Double delta seals must be replaced during the installation of the valve stem assemblies. Do not remove them at this time.

- h. Disconnect the valve stem removal tool, valve stem removal tool base and piston head adapter from the piston.
- i. Remove the screws that secure the spacer to the piston.

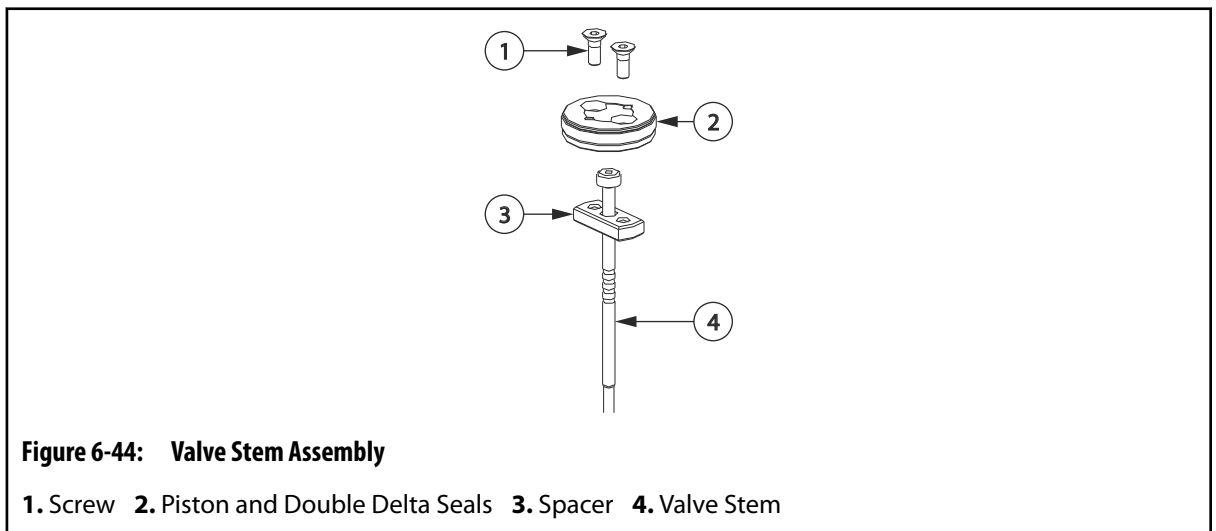

- j. Remove the valve stem from the spacer.
5. Inspect the gate end of the valve stems to make sure there is no damage or wear. If possible, use a new valve stem for comparison.

**WARNING!**

Burn, fire and gas hazard – risk of death or serious injury, and property damage. Use of an open flame to remove resin can produce harmful gases (depending on the resin type), damage components and increase the risk of fire. Only use open flames sparingly and in a controlled environment.



WARNING!

Burn hazard – risk of serious injury. To avoid serious burns, wear personal protective equipment consisting of a heat-resistant coat, heat-resistant gloves, and a full face shield over safety glasses. Use adequate ventilation for fumes.

CAUTION!

Mechanical hazard – risk of damage to the equipment. Abrasives should never be used to clean the valve stems, as this could damage the critical sealing surfaces.

6. Remove any resin deposits from the valve stems. If required, carefully heat the resin deposits with a propane torch and then wipe the deposits away with a clean, soft cloth. This may have to be repeated several times.
7. Make sure the valve stems are not overheated, scratched, scored, bent or worn. Replace each valve stem if it shows signs of this type of damage.

6.12.2 Installing the Valve Stems for U350 and U500 VG-SX Systems

To install valve stems into the hot runner, do the following:

NOTE:

This procedure can be performed in the machine or on a work bench.



IMPORTANT!

Husky recommends that the Ultra Helix valve gate nozzle tip be removed before the installation of the valve stem.

1. For each valve stem assembly, do the following:
 - a. Make sure all components are clean and free of resin, scratches, nicks or burrs. Replace as necessary.

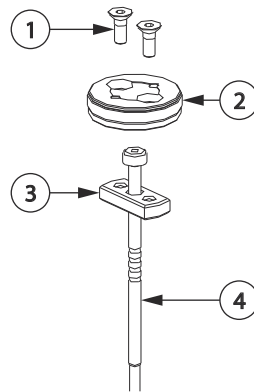

Figure 6-45: Valve Stem Assembly

1. Screw 2. Piston and Double Delta Seals 3. Spacer 4. Valve Stem

- b.** Insert the valve stem through the spacer.
 - c.** Inspect the O-ring seals embedded in the screws. Replace the screws if the O-ring seals are worn, damaged or missing.
 - d.** Apply a static application grease to the threads of the screws. Refer to [Section 3.5](#) for a list of recommended lubricants.
 - e.** Place the valve stem and spacer against the bottom of the piston and install the screws. Torque the screws to the value specified on the assembly drawings.
 - f.** Rotate the valve stem to make sure no binding has occurred. The valve stem should rotate freely.
 - g.** Replace the double delta seals. Refer to [Section 6.13](#) for more information.
- 2.** If the valve stems will be installed while the hot runner is cold, proceed to [step 3](#). However, if the valve stems will be installed while the hot runner is hot, do the following:
 - a.** Reconnect any thermocouples that were disconnected during disassembly.
 - b.** Connect the hot runner to a controller.
 - c.** Turn on the controller.



DANGER!

Electrocution hazard – risk of death, serious injury and/or damage to the hot runner. Do not turn on the heaters if water has leaked into the hot runner. If water has leaked into the hot runner, the hot runner must be completely disassembled, dried and assembled before the heaters are turned on.



WARNING!

Hot resin spray hazard – risk of serious injury. Hot resin may unexpectedly spray from the nozzle tips while the hot runner is reaching operating temperature. To avoid serious burns, wear personal protective equipment consisting of a heat-resistant coat, heat-resistant gloves and a full face shield over safety glasses. Use adequate ventilation for fumes.



WARNING!

Burn hazard – risk of serious injury. Hot runner components stay hot for long periods of time after heaters have been turned off. Wear personal protective equipment when working near the hot runner and place a warning sign in the area before leaving the hot runner unattended.

- d. Increase the temperature of the hot runner to a temperature high enough to soften the resin in the melt channels.

NOTE:

Heating the nozzles will minimize the misalignment between the manifold bushings and nozzles and will guarantee that the plastic in the system is soft enough not to deflect the stem during installation.

NOTE:

The Vicat Softening Temperature for the resin type is recommended. Refer to the resin supplier’s documentation for more information.



WARNING!

Electrocution hazard - risk of death or serious injury. Complete the lockout/tagout procedure of the electrical power source before disconnecting the electrical connectors.

- e. Lock out and tag the electrical power source.



IMPORTANT!

Do not allow the nozzle tips to overheat or degraded material will have to be cleaned out of the nozzle housing before a new nozzle tip can be installed.

- f. Disconnect the controller.
- g. Verify that the manifold hold down screws are fastened securely.
- h. Insert the alignment tool until the small diameter starts to engage the tip (approximately 10 mm (0.4 in) from the end of insertion) to pre-align the tip.

NOTE:

If an alignment tool is not available, an old stem with the plunger section removed may be used.

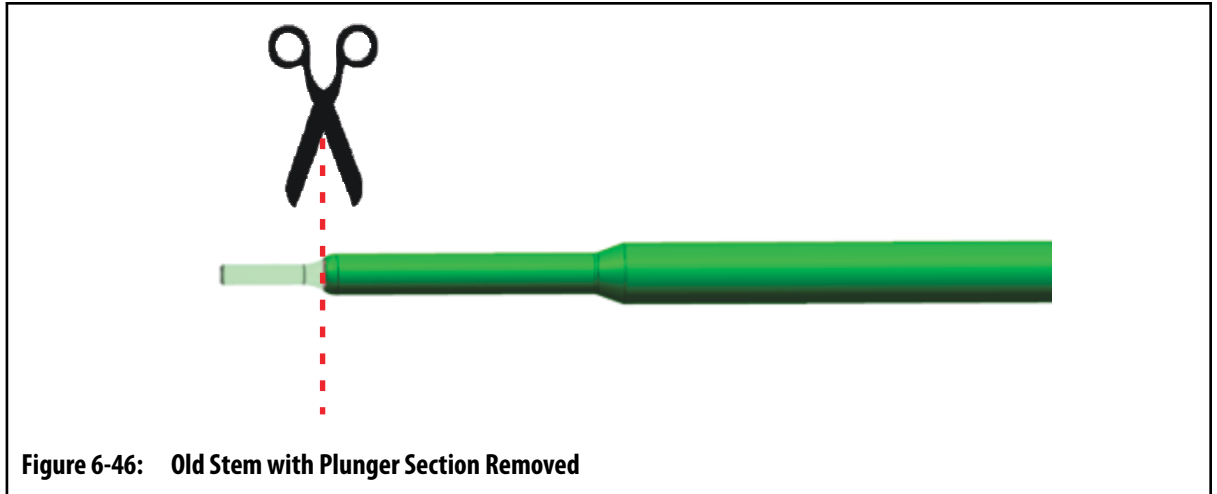
**IMPORTANT!**

Some resistance may be felt while inserting the alignment tool. If this occurs, rotate the tool slightly and then continue the installation.

- i. When the tool slides back and forth easily in the guide, remove the tool.

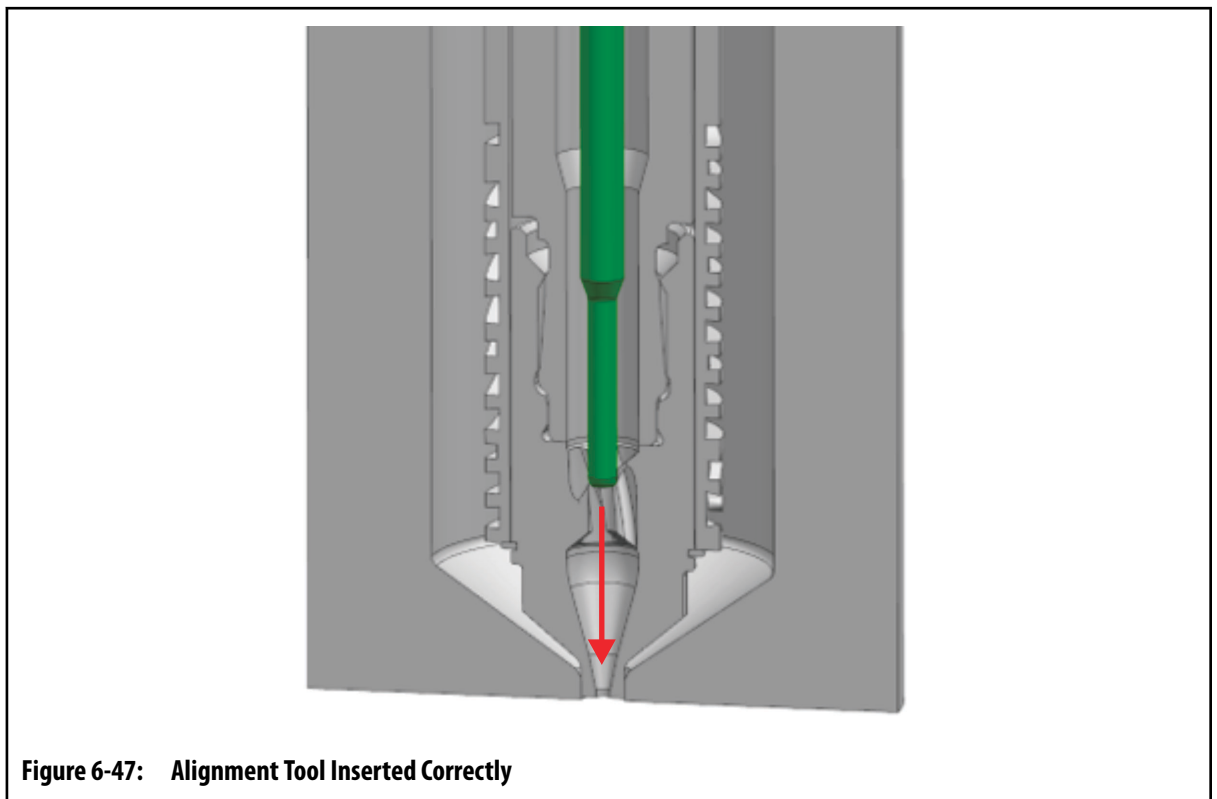



IMPORTANT!

The stem should be installed promptly after removing the alignment tool to minimize the flow of molten plastic into the void created.

CAUTION!

Mechanical hazard - risk of damage to the equipment. Never try to force the valve stem forward if resistance is felt. Doing so may result in the plunger and guide being damaged.

- j. Install the valve stem by hand until the head is 15 mm (0.6 in) from being fully seated in the actuation plate or cylinder.

NOTE:

Resistance should not be felt when the stem encounters the scraper or manifold bushing. If resistance is felt, rotate the stem while continuing to apply slight pressure until resistance is no longer felt.

- k. Carefully insert the stem for the final 10 mm (0.4 in) .



IMPORTANT!

If the stem is severely misaligned, there is a possibility that the plunger has entered one of the helical grooves in the tip. If this happens, pull the stem back and rotate it slightly, then continue the installation.

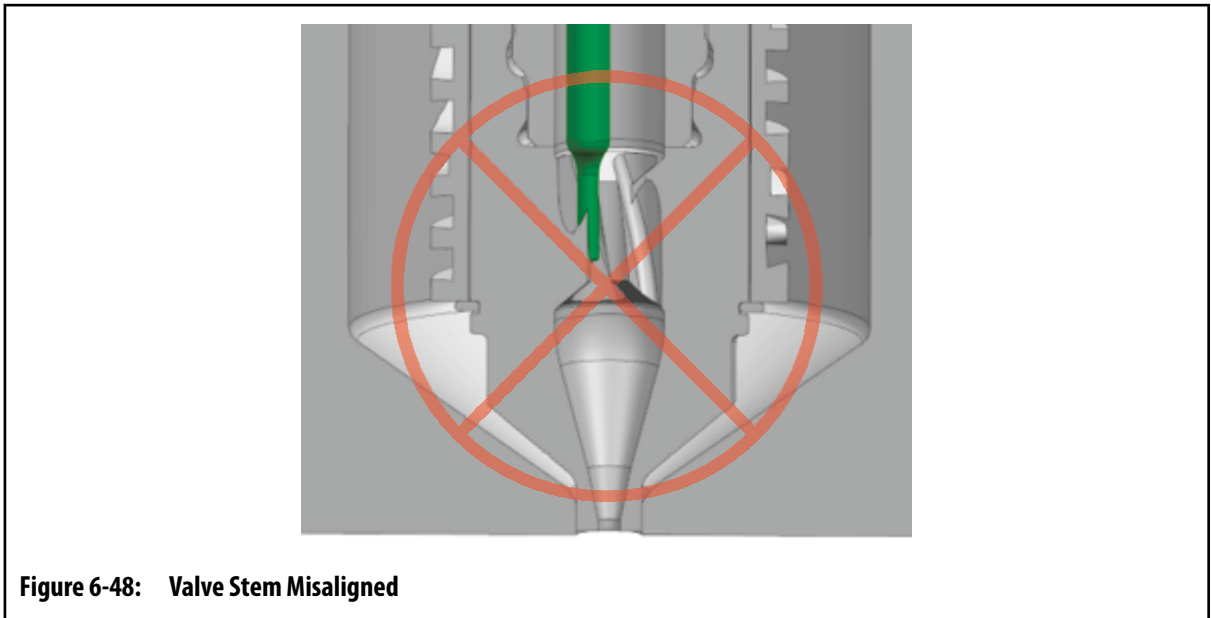

Figure 6-48: Valve Stem Misaligned

- 3. Carefully insert the valve stem assemblies into the cylinder. Make sure the pistons are seated below the top surface of the cylinders.

**IMPORTANT!**

In a hot installation, if the stem is severely misaligned, there is a possibility that the plunger has entered one of the helical grooves in the tip. If this happens, pull the stem back and rotate it slightly, then continue the installation.

4. If equipped, install the center plate. Refer to [Section 6.8](#) for more information.
5. Install the backing plate. Refer to [Section 6.7](#) for more information.

6.12.3 Removing the Valve Stems for U500 and U750 VG-LX and EX Systems

Valve stems can be removed when the hot runner is cold or hot, with each method offering its own advantages and disadvantages.

Cold		Hot	
Advantage	Disadvantage	Advantage	Disadvantage
<ul style="list-style-type: none"> • Fast removal reduces down time • Easy to clean • No danger from heat 	<ul style="list-style-type: none"> • Valve stem may break • More difficult to remove valve stem 	<ul style="list-style-type: none"> • Reduces the risk of valve stems breaking • Valve stems are easy to remove 	<ul style="list-style-type: none"> • Slow, increased down time • Difficult to clean • Danger from heat

To remove valve stems from the hot runner, do the following:

NOTE:

This procedure can be performed in the machine or on a work bench.

1. Remove the backing plate. Refer to [Section 6.7](#) for more information.
2. If equipped, remove the center plate. Refer to [Section 6.8](#) for more information.
3. If the valve stems will be removed while the hot runner is cold, proceed to [step 4](#). However, if the valve stems will be removed while the hot runner is hot, do the following:
 - a. Reconnect any thermocouples that were disconnected during disassembly.
 - b. Connect the hot runner to a controller.
 - c. Turn on the controller.

**DANGER!**

Electrocution hazard – risk of death, serious injury and/or damage to the hot runner. Do not turn on the heaters if water has leaked into the hot runner. If water has leaked into the hot runner, the hot runner must be completely disassembled, dried and assembled before the heaters are turned on.



WARNING!

Hot resin spray hazard – risk of serious injury. Hot resin may unexpectedly spray from the nozzle tips while the hot runner is reaching operating temperature. To avoid serious burns, wear personal protective equipment consisting of a heat-resistant coat, heat-resistant gloves and a full face shield over safety glasses. Use adequate ventilation for fumes.



WARNING!

Burn hazard – risk of serious injury. Hot runner components stay hot for long periods of time after heaters have been turned off. Wear personal protective equipment when working near the hot runner and place a warning sign in the area before leaving the hot runner unattended.



WARNING!

Electrocution hazard - risk of death or serious injury. Complete the lockout/tagout procedure of the electrical power source before disconnecting the electrical connectors.

- d. Increase the temperature of the hot runner to a temperature high enough to soften the resin in the melt channels.

NOTE:

The Vicat Softening Temperature for the resin type is recommended. Refer to the resin supplier’s documentation for more information.



WARNING!

Electrocution hazard - risk of death or serious injury. Complete the lockout/tagout procedure of the electrical power source before disconnecting the electrical connectors.

- e. Lock out and tag the electrical power source.



IMPORTANT!

Do not allow the nozzle tips to overheat or degraded material will have to be cleaned out of the nozzle housing before a new nozzle tip can be installed.

- f. Disconnect the controller.
- 4. For each valve stem to be removed, do the following:
 - a. Remove the piston cylinder from the piston.

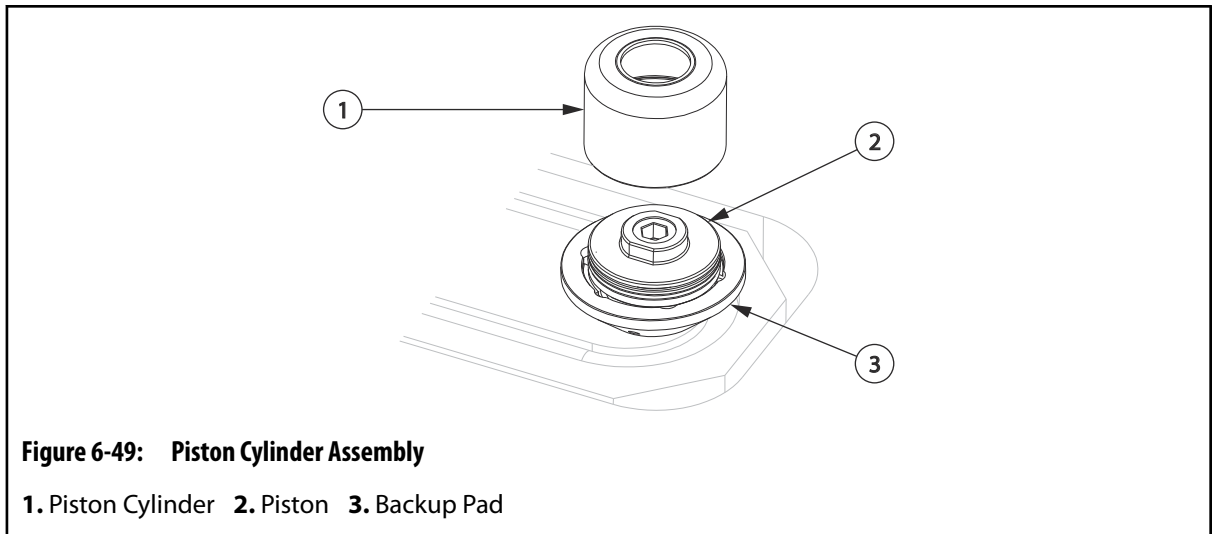

- b. From the valve stem removal tool assembly, connect the interface tool to the piston.

NOTE:

Refer to [Section 1.8](#) for a list of special tools and part numbers.

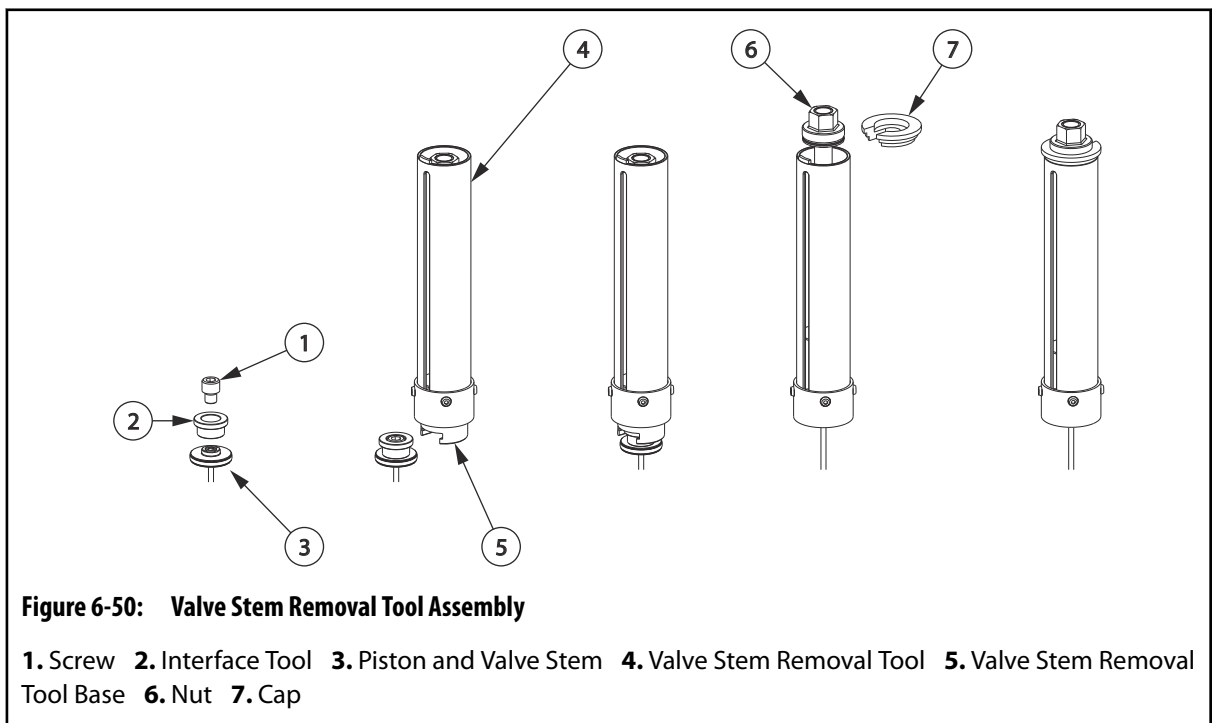

- c. Slide the valve stem removal tool base onto the interface tool.
 d. Lower the sleeve and insert the cap beneath the thrust washers.
 e. Hold the valve stem removal tool in place and rotate the top nut clockwise until it is tight.

CAUTION!

Mechanical hazard – risk of damage to the equipment. Be careful not to bend the valve stem when removing it. Bent valve stems cannot be re-used.

CAUTION!

Mechanical hazard – risk of damage to the equipment. If the valve stem and piston do not pull out easily, the valve stem may have seized in the manifold bushing. If this is the case, remove the manifold bushing from the manifold and remove the valve stem. Contact Husky for more information.

- f. Using a wrench, rotate the nut on the valve stem removal tool clockwise to remove the valve stem assembly.

NOTE:

Double delta seals must be replaced during the installation of the valve stem assemblies. Do not remove them at this time.

- g. Remove the set screw and valve stem from the piston.

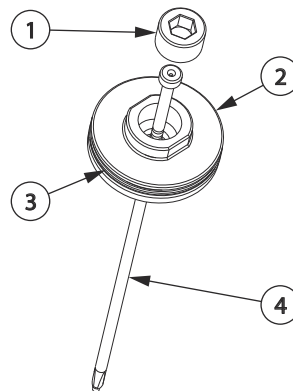

Figure 6-51: Valve Stem Assembly

- 1. Set Screw 2. Piston 3. Double Delta Seal 4. Valve Stem

- 5. Inspect the gate end of the valve stems to make sure there is no damage or wear. If possible, use a new valve stem for comparison.



WARNING!

Burn, fire and gas hazard – risk of death or serious injury, and property damage. Use of an open flame to remove resin can produce harmful gases (depending on the resin type), damage components and increase the risk of fire. Only use open flames sparingly and in a controlled environment.

**WARNING!**

Burn hazard – risk of serious injury. To avoid serious burns, wear personal protective equipment consisting of a heat-resistant coat, heat-resistant gloves, and a full face shield over safety glasses. Use adequate ventilation for fumes.

CAUTION!

Mechanical hazard – risk of damage to the equipment. Abrasives should never be used to clean the valve stems, as this could damage the critical sealing surfaces.

6. Remove any resin deposits from the valve stems. If required, carefully heat the resin deposits with a propane torch and then wipe the deposits away with a clean, soft cloth. This may have to be repeated several times.
7. Make sure the valve stems are not overheated, scratched, scored, bent or worn. Replace each valve stem if it shows signs of this type of damage.

6.12.4 Installing the Valve Stems for U500 and U750 VG-LX and EX Systems

To install valve stems into the hot runner, do the following:

NOTE:

This procedure can be performed in the machine or on a work bench.

**IMPORTANT!**

Husky recommends that the Ultra Helix valve gate nozzle tip be removed before the installation of the valve stem.

1. For each valve stem assembly, do the following:
 - a. Make sure all components are clean and free of resin, scratches, nicks or burrs. Replace as necessary.

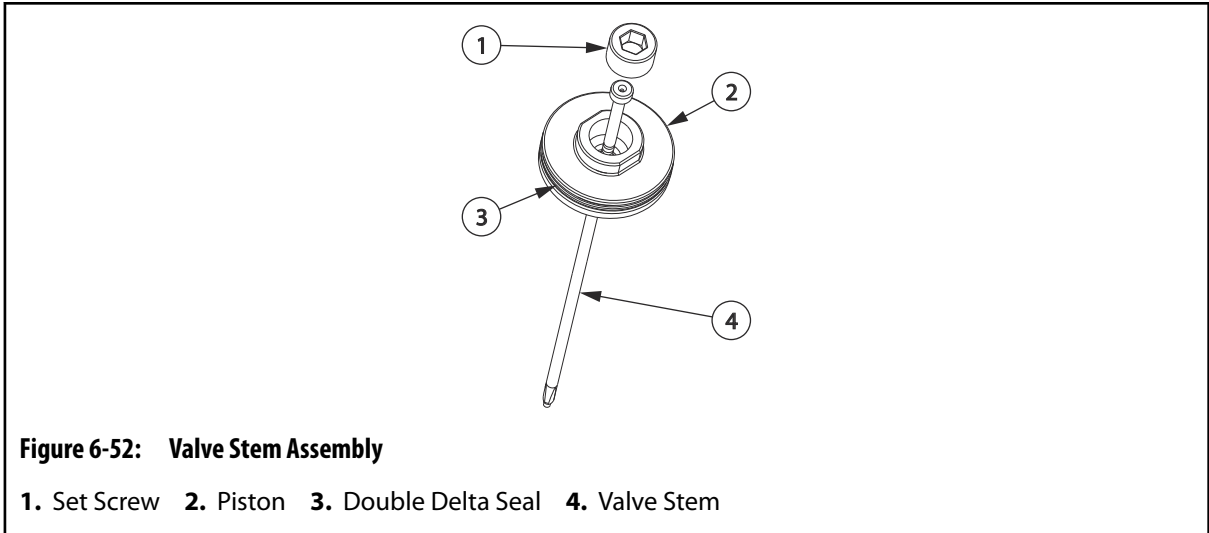

- b. Insert the valve stem through the piston.
 - c. Apply a static application grease to the threads of the set screw. Refer to [Section 3.5](#) for a list of recommended lubricants.
 - d. Install the set screw into the piston and hand tighten.
 - e. While holding the piston with a wrench or vice, torque the set screw to the specified value. Refer to the assembly drawings for torque values.
 - f. Rotate the valve stem to make sure no binding has occurred. The valve stem should rotate freely.
 - g. Replace the double delta seals and install the piston cylinder. Refer to [Section 6.13](#) for more information.
2. If the valve stems will be installed while the hot runner is cold, proceed to [step 3](#). However, if the valve stems will be installed while the hot runner is hot, do the following:
- a. Reconnect any thermocouples that were disconnected during disassembly.
 - b. Connect the hot runner to a controller.
 - c. Turn on the controller.



DANGER!

Electrocution hazard – risk of death, serious injury and/or damage to the hot runner. Do not turn on the heaters if water has leaked into the hot runner. If water has leaked into the hot runner, the hot runner must be completely disassembled, dried and assembled before the heaters are turned on.



WARNING!

Hot resin spray hazard – risk of serious injury. Hot resin may unexpectedly spray from the nozzle tips while the hot runner is reaching operating temperature. To avoid serious burns, wear personal protective equipment consisting of a heat-resistant coat, heat-resistant gloves and a full face shield over safety glasses. Use adequate ventilation for fumes.

**WARNING!**

Burn hazard – risk of serious injury. Hot runner components stay hot for long periods of time after heaters have been turned off. Wear personal protective equipment when working near the hot runner and place a warning sign in the area before leaving the hot runner unattended.

- d. Increase the temperature of the hot runner to a temperature high enough to soften the resin in the melt channels.

NOTE:

The Vicat Softening Temperature for the resin type is recommended. Refer to the resin supplier's documentation for more information.

**WARNING!**

Electrocution hazard - risk of death or serious injury. Complete the lockout/tagout procedure of the electrical power source before disconnecting the electrical connectors.

- e. Lock out and tag the electrical power source.

**IMPORTANT!**

Do not allow the nozzle tips to overheat or degraded material will have to be cleaned out of the nozzle housing before a new nozzle tip can be installed.

- f. Disconnect the controller.
3. Carefully insert the valve stem assemblies into the manifold(s). Make sure the piston cylinders are fully seated in the backup pads.
4. If equipped, install the center plate. Refer to [Section 6.8](#) for more information.
5. Install the backing plate. Refer to [Section 6.7](#) for more information.

6.12.5 Removing the Valve Stems for U1000 VG-LX Systems

Valve stems can be removed when the hot runner is cold or hot, with each method offering its own advantages and disadvantages.

Cold		Hot	
Advantage	Disadvantage	Advantage	Disadvantage
<ul style="list-style-type: none"> • Fast removal reduces down time • Easy to clean • No danger from heat 	<ul style="list-style-type: none"> • Valve stem may break • More difficult to remove valve stem 	<ul style="list-style-type: none"> • Reduces the risk of valve stems breaking • Valve stems are easy to remove 	<ul style="list-style-type: none"> • Slow, increased down time • Difficult to clean • Danger from heat

To remove valve stems from the hot runner, do the following:

NOTE:

This procedure can be performed in the machine or on a work bench.

1. Remove the backing plate. Refer to [Section 6.7](#) for more information.
2. If equipped, remove the center plate. Refer to [Section 6.8](#) for more information.
3. If the valve stems will be removed while the hot runner is cold, proceed to [step 4](#). However, if the valve stems will be removed while the hot runner is hot, do the following:
 - a. Reconnect any thermocouples that were disconnected during disassembly.
 - b. Connect the hot runner to a controller.
 - c. Turn on the controller.



DANGER!

Electrocution hazard – risk of death, serious injury and/or damage to the hot runner. Do not turn on the heaters if water has leaked into the hot runner. If water has leaked into the hot runner, the hot runner must be completely disassembled, dried and assembled before the heaters are turned on.



WARNING!

Hot resin spray hazard – risk of serious injury. Hot resin may unexpectedly spray from the nozzle tips while the hot runner is reaching operating temperature. To avoid serious burns, wear personal protective equipment consisting of a heat-resistant coat, heat-resistant gloves and a full face shield over safety glasses. Use adequate ventilation for fumes.



WARNING!

Burn hazard – risk of serious injury. Hot runner components stay hot for long periods of time after heaters have been turned off. Wear personal protective equipment when working near the hot runner and place a warning sign in the area before leaving the hot runner unattended.

- d. Increase the temperature of the hot runner to a temperature high enough to soften the resin in the melt channels.

NOTE:

The Vicat Softening Temperature for the resin type is recommended. Refer to the resin supplier’s documentation for more information.

**WARNING!**

Electrocution hazard - risk of death or serious injury. Complete the lockout/tagout procedure of the electrical power source before disconnecting the electrical connectors.

- e. Lock out and tag the electrical power source.

**IMPORTANT!**

Do not allow the nozzle tips to overheat or degraded material will have to be cleaned out of the nozzle housing before a new nozzle tip can be installed.

- f. Disconnect the controller.
4. For each valve stem to be removed, do the following:
 - a. Remove the piston cylinder from the piston.

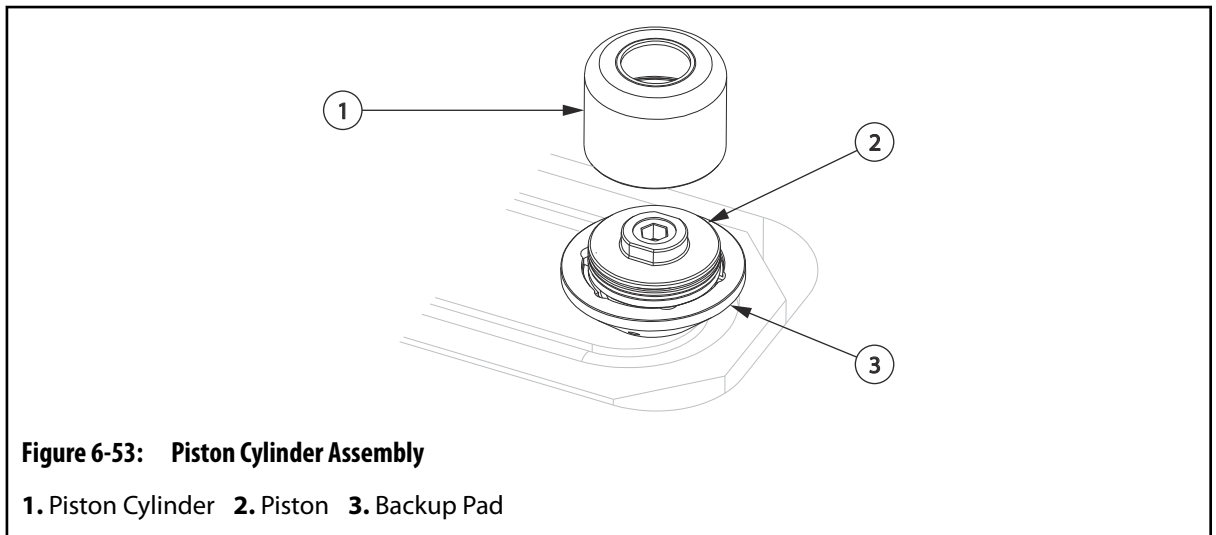

- b. From the valve stem removal tool assembly, connect the interface tool to the piston.

NOTE:

Refer to [Section 1.8](#) for a list of special tools and part numbers.

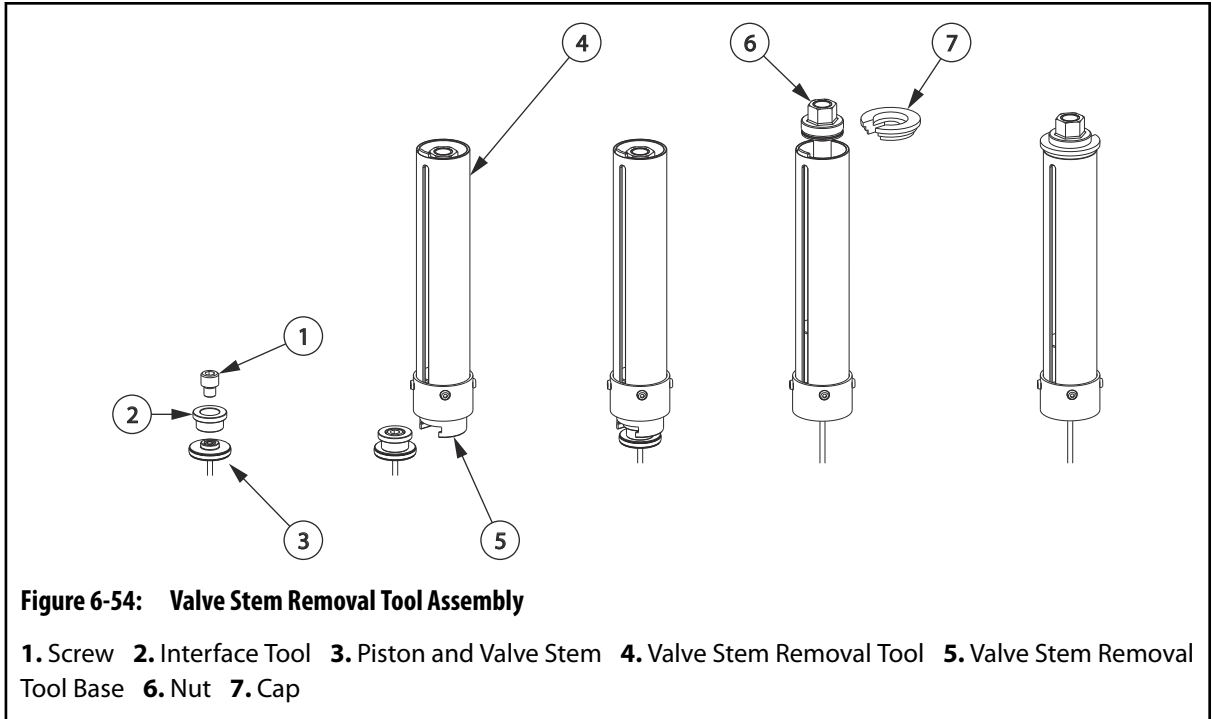

Figure 6-54: Valve Stem Removal Tool Assembly

1. Screw **2.** Interface Tool **3.** Piston and Valve Stem **4.** Valve Stem Removal Tool **5.** Valve Stem Removal Tool Base **6.** Nut **7.** Cap

- c. Slide the valve stem removal tool base over the interface tool.
- d. Lower the sleeve and insert the cap beneath the thrust washers.
- e. Hold the valve stem removal tool in place and rotate the top nut clockwise until it is tight.

CAUTION!

Mechanical hazard – risk of damage to the equipment. Be careful not to bend the valve stem when removing it. Bent valve stems cannot be re-used.

CAUTION!

Mechanical hazard – risk of damage to the equipment. If the valve stem and piston do not pull out easily, the valve stem may have seized in the manifold bushing. If this is the case, remove the manifold bushing from the manifold and remove the valve stem. Contact Husky for more information.

- f. Using a wrench, rotate the nut on the valve stem removal tool clockwise to remove the valve stem assembly.

NOTE:

Double delta seals must be replaced during the installation of the valve stem assemblies. Do not remove them at this time.

- g. Remove the piston spacer and valve stem from the piston.

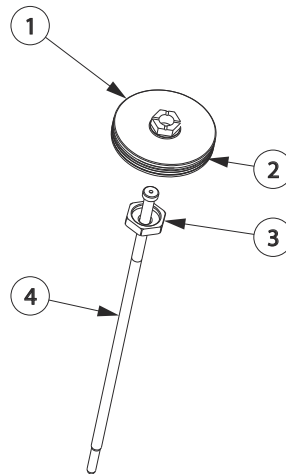

Figure 6-55: Valve Stem Assembly

1. Piston 2. Double Delta Seal 3. Piston Spacer 4. Valve Stem

5. Inspect the gate end of the valve stems to make sure there is no damage or wear. If possible, use a new valve stem for comparison.



WARNING!

Burn, fire and gas hazard – risk of death or serious injury, and property damage. Use of an open flame to remove resin can produce harmful gases (depending on the resin type), damage components and increase the risk of fire. Only use open flames sparingly and in a controlled environment.



WARNING!

Burn hazard – risk of serious injury. To avoid serious burns, wear personal protective equipment consisting of a heat-resistant coat, heat-resistant gloves, and a full face shield over safety glasses. Use adequate ventilation for fumes.

CAUTION!

Mechanical hazard – risk of damage to the equipment. Abrasives should never be used to clean the valve stems, as this could damage the critical sealing surfaces.

6. Remove any resin deposits from the valve stems. If required, carefully heat the resin deposits with a propane torch and then wipe the deposits away with a clean, soft cloth. This may have to be repeated several times.
7. Make sure the valve stems are not overheated, scratched, scored, bent or worn. Replace each valve stem if it shows signs of this type of damage.

6.12.6 Installing the Valve Stems for U1000 VG-LX Systems

To install valve stems into the hot runner, do the following:

NOTE:

This procedure can be performed in the machine or on a work bench.

1. For each valve stem assembly, do the following:
 - a. Make sure all components are clean and free of resin, scratches, nicks or burrs. Replace as necessary.

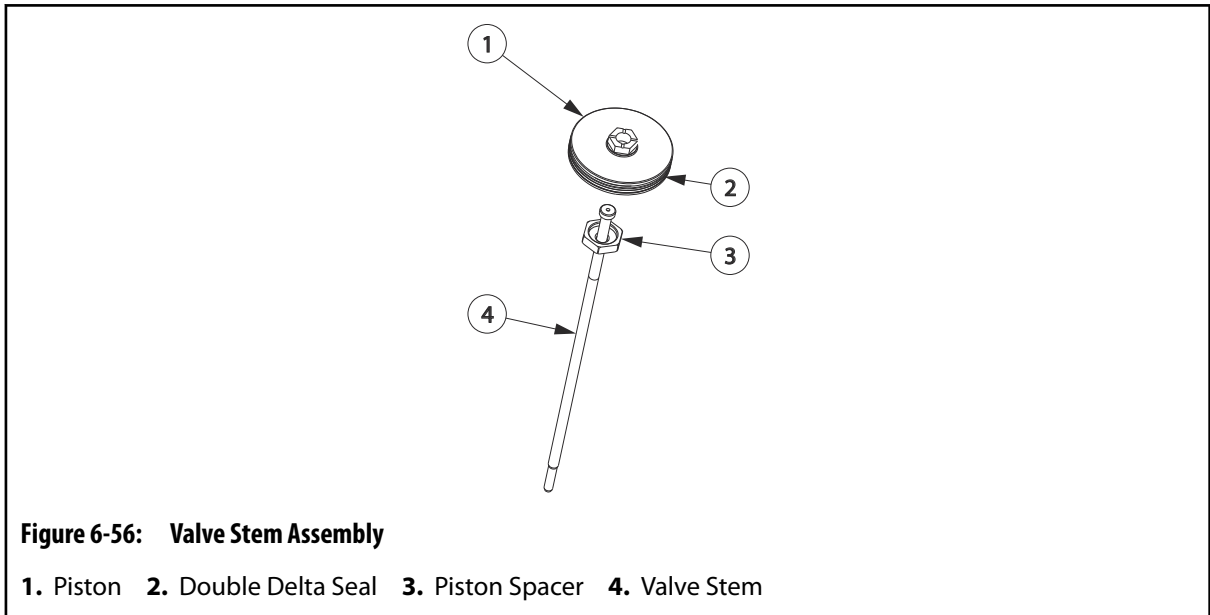

- b. Insert the valve stem through the piston.
 - c. Apply a static application grease to the inside threads of the piston spacer. Refer to [Section 3.5](#) for a list of recommended lubricants.
 - d. Slide the piston spacer over the valve stem tip and thread it onto the bottom of the piston.
 - e. While holding the piston with a wrench or vice, torque the piston spacer to the specified value. Refer to the assembly drawings for torque values.
 - f. Rotate the valve stem to make sure no binding has occurred. The valve stem should rotate freely.
 - g. Replace the double delta seals and install the piston cylinder. Refer to [Section 6.13](#) for more information.
2. If the valve stems will be installed while the hot runner is cold, proceed to [step 3](#). However, if the valve stems will be installed while the hot runner is hot, do the following:
 - a. Reconnect any thermocouples that were disconnected during disassembly.
 - b. Connect the hot runner to a controller.
 - c. Turn on the controller.

**DANGER!**

Electrocution hazard – risk of death, serious injury and/or damage to the hot runner. Do not turn on the heaters if water has leaked into the hot runner. If water has leaked into the hot runner, the hot runner must be completely disassembled, dried and assembled before the heaters are turned on.

**WARNING!**

Hot resin spray hazard – risk of serious injury. Hot resin may unexpectedly spray from the nozzle tips while the hot runner is reaching operating temperature. To avoid serious burns, wear personal protective equipment consisting of a heat-resistant coat, heat-resistant gloves and a full face shield over safety glasses. Use adequate ventilation for fumes.

**WARNING!**

Burn hazard – risk of serious injury. Hot runner components stay hot for long periods of time after heaters have been turned off. Wear personal protective equipment when working near the hot runner and place a warning sign in the area before leaving the hot runner unattended.

- d. Increase the temperature of the hot runner to a temperature high enough to soften the resin in the melt channels.

NOTE:

The Vicat Softening Temperature for the resin type is recommended. Refer to the resin supplier's documentation for more information.

**WARNING!**

Electrocution hazard - risk of death or serious injury. Complete the lockout/tagout procedure of the electrical power source before disconnecting the electrical connectors.

- e. Lock out and tag the electrical power source.

**IMPORTANT!**

Do not allow the nozzle tips to overheat or degraded material will have to be cleaned out of the nozzle housing before a new nozzle tip can be installed.

- f. Disconnect the controller.
3. Carefully insert the valve stem assemblies into the manifold(s). Make sure the piston cylinders are fully seated in the backup pads.
4. If equipped, install the center plate. Refer to [Section 6.8](#) for more information.
5. Install the backing plate. Refer to [Section 6.7](#) for more information.

6.13 Replacing the Double Delta Seals

To replace the double delta seals on the pistons, do the following:

1. Remove the backing plate. Refer to [Section 6.7](#) for more information.
2. If equipped, remove the center plate. Refer to [Section 6.8.1](#) for more information.
3. Remove the valve stem assemblies. Refer to [Section 6.12](#) for more information.
4. For each valve stem assembly that requires new double delta seals, do the following:
 - a. For VG-LX/EX hot runners only, remove, clean and inspect the piston cylinder. If the piston cylinder is damaged, replace it immediately.

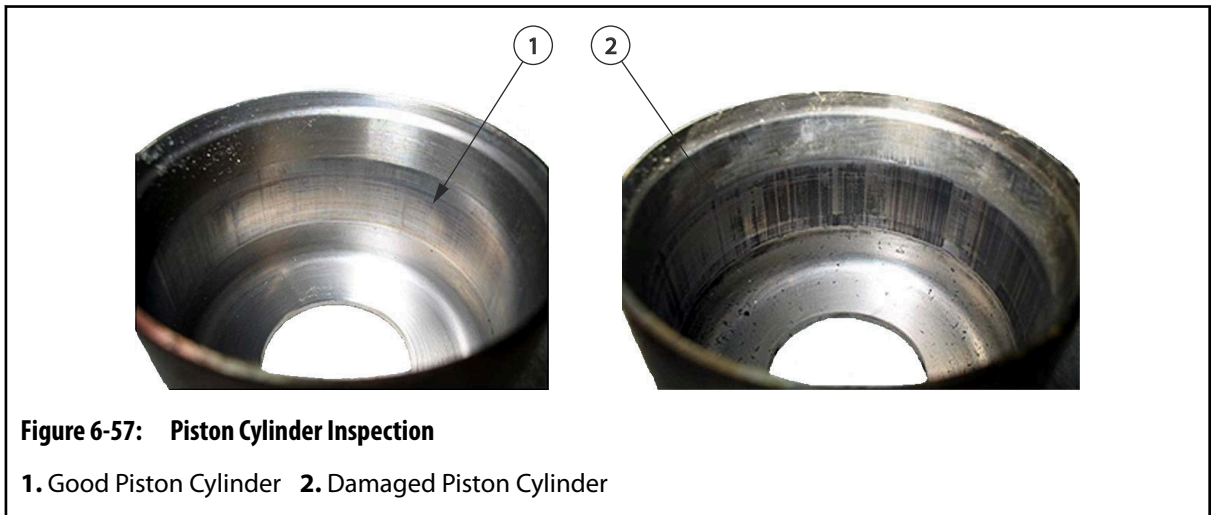

CAUTION!

Mechanical hazard – risk of damage to the equipment. Do not damage the pistons when removing the seals. This will later diminish the integrity of the new seals.

- b. Remove the outer and inner seals from the piston.



IMPORTANT!

Pistons must be cleaned before new seals are installed. Any debris or grease present will shorten the service life of the seals.

- c. Remove any loose debris or grease from the piston and surrounding area.
- d. Install the interior O-ring seal into the seal groove by rolling it over the piston. No tools are required.

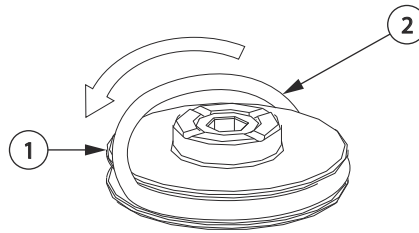

Figure 6-58: Installing the Inner O-Ring Seal

1. Piston 2. Inner O-Ring Seal

- e. Place the seal installation tool on top of the piston.

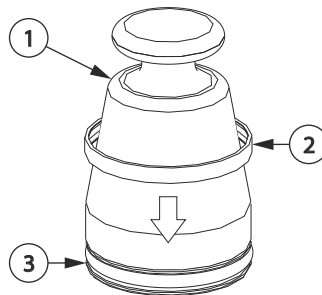

Figure 6-59: Installing the Outer O-Ring Seal

1. Seal Installation Tool 2. Outer O-Ring Seal 3. Piston

- f. Install the outer O-ring seal by pushing the seal over the seal installation tool until it sits over the interior O-ring seal.
- g. Remove the seal installation tool.
- h. Slide the piston installation tool over the piston to compress the seals. This will protect the seals from damage when the piston cylinder is installed.
- i. Inspect the piston assembly for damage, debris or grease.

NOTE:

The piston cylinder is easier to install when it is installed shortly after the piston installation tool is removed.

- j. For VG-LX/EX hot runners only, install the piston cylinder.
5. Install the valve stem assemblies. Refer to [Section 6.12](#) for more information.
6. If equipped, install the center plate. Refer to [Section 6.8.2](#) for more information.
7. Install the backing plate. Refer to [Section 6.7](#) for more information.

6.14 Removing and Installing Nozzle Tips

The following procedures describe how to remove and install nozzle tips.

**IMPORTANT!**

The Ultra Helix Valve Gate nozzle heater must be removed to allow full engagement of the torque tool. The Husky supplied torque tool must be used to install the Ultra Helix nozzle tip or the tip may be damaged.

NOTE:

On VG-HP systems, the nozzle tip and nozzle housing are one piece. Refer [Section 6.16](#) to for information about removing the nozzle tip and housing.

NOTE:

When removing the nozzle tips, it is recommended they be removed when the hot runner is at room temperature (< 25 °C or < 77 °F).

NOTE:

For U750 nozzle tips with U1000 VG-EXX RGA nozzles, refer to [Section 6.14.3](#) for information about removing the nozzle tip and adapter, and [Section 6.14.5](#) for information about installing the nozzle tip and adapter.

6.14.1 Removing the Nozzle Tips when Hot

To remove the nozzle tips when they are hot, do the following:

NOTE:

The following procedure should only be performed when the nozzle tips cannot be removed when the hot runner is at room temperature (< 25 °C or < 77 °F).

1. Separate or remove the cavity plate from the hot runner. Refer to [Section 6.6](#) for more information.
2. Remove all nozzle heater components except for the nozzle heater and thermocouple. Refer to [Section 6.17](#) for more information.
3. If necessary, connect the hot runner to a controller.
4. Remove all locks and tags. Refer to [Section 2.5](#) for more information.
5. Power up the machine or turn on the controller (if equipped).

**DANGER!**

Electrocution hazard – risk of death, serious injury and/or damage to the hot runner. Do not turn on the heaters if water has leaked into the hot runner. If water has leaked into the hot runner, the hot runner must be completely disassembled, dried and assembled before the heaters are turned on.

**WARNING!**

Hot resin spray hazard – risk of serious injury. Hot resin may unexpectedly spray from the nozzle tips while the hot runner is reaching operating temperature. To avoid serious burns, wear personal protective equipment consisting of a heat-resistant coat, heat-resistant gloves and a full face shield over safety glasses. Use adequate ventilation for fumes.

**WARNING!**

Burn hazard – risk of serious injury. Hot runner components stay hot for long periods of time after heaters have been turned off. Wear personal protective equipment when working near the hot runner and place a warning sign in the area before leaving the hot runner unattended.

6. Increase the temperature of the nozzle housings to a temperature high enough to soften the resin around the nozzle tip threads. If there is no resin in the system, set the heat zones to room temperature (<25 °C or <77 °F).

NOTE:

The Vicat Softening Temperature for the resin type is recommended. Refer to the resin supplier's documentation for more information.

**IMPORTANT!**

Do not allow the nozzle tips to overheat or degraded material will have to be cleaned out of the nozzle housing before a new nozzle tip can be installed.

7. Lock out and tag the machine and controller (if equipped).

**WARNING!**

Burn hazard – risk of serious injury. To avoid serious burns, wear personal protective equipment consisting of a heat-resistant coat, heat-resistant gloves, and a full face shield over safety glasses. Use adequate ventilation for fumes.

CAUTION!

Mechanical hazard – risk of damage to the equipment. Support nozzle tip sockets squarely over the nozzle tips to prevent side-load on the tip.

8. Using an appropriate nozzle tip socket, loosen each nozzle tip that will be removed. Do not unscrew or remove the nozzle tips.

Refer to [Section 1.8](#) for a list of available nozzle tip sockets.



WARNING!

Burn hazard – risk of serious injury. To avoid serious burns, wear personal protective equipment consisting of a heat-resistant coat, heat-resistant gloves and a full face shield over safety glasses. Use adequate ventilation for fumes.

9. Wearing appropriate personal protective equipment, hand tighten each nozzle tip while the resin is still soft until the nozzle tips touch the nozzle housing.
10. Allow the nozzle tips to cool to room temperature (< 25 °C or < 77 °F). This may take 1/2 to 4 hours depending on the size of the hot runner. However, this step will reduce the risk of resin solidifying on the nozzle tip sealing surfaces.
11. Remove the nozzle tips using the nozzle tip socket.

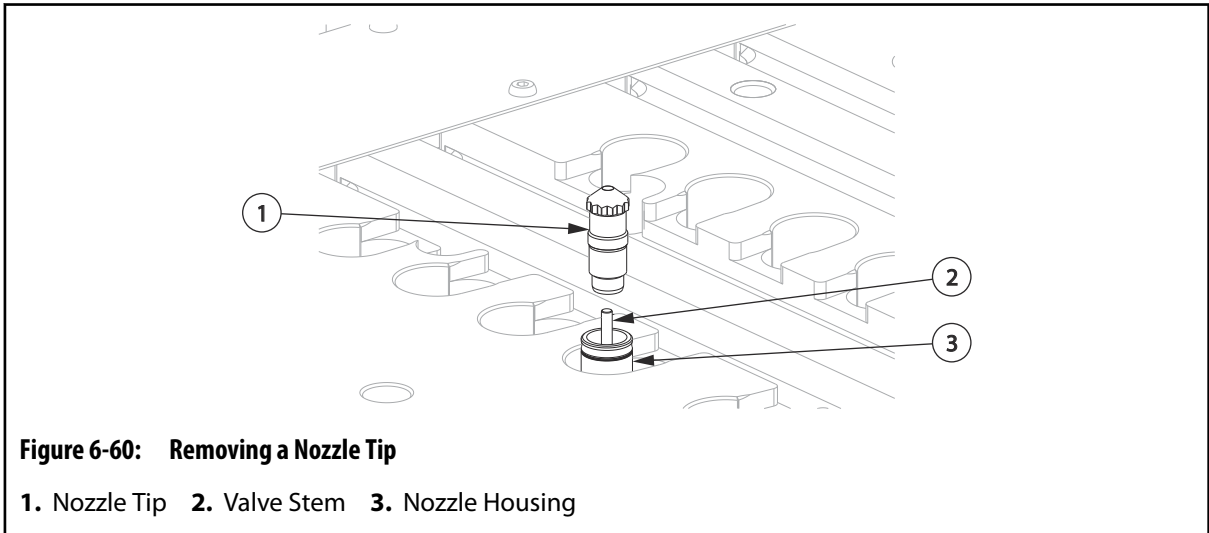

12. Remove the nozzle heaters. Refer to [Section 6.17](#) for more information.



IMPORTANT!

Care must be taken to prevent damage to the nozzle tip and nozzle sealing surfaces.

13. Remove any resin from the interior of the nozzle tip using a soft wire brush or equivalent.
14. Remove any resin from the interior and exterior of the nozzle housing using a soft wire brush or equivalent.

NOTE:

Do not remove locks and tags until the nozzle tips are installed.

6.14.2 Removing the Nozzle Tips when Cold

To remove the nozzle tips when they are cold, do the following:

1. Separate or remove the cavity plate from the hot runner. Refer to [Section 6.6](#) for more information.

2. Remove all nozzle heater components except for the nozzle heater and thermocouple. Refer to [Section 6.17](#) for more information.

CAUTION!

Mechanical hazard – risk of damage to the hot runner. Solidified resin can make it difficult to loosen the nozzle tips. Too much force when loosening the nozzle tips could damage the sealing surfaces or damage (stretch or break) the valve stems.

If the nozzle tips do not loosen easily, heat up the nozzle tips before removing them. Refer to [Section 6.14.1](#) for more information.

3. Using an appropriate nozzle tip socket, loosen each nozzle tip that will be removed. Do not unscrew or remove the nozzle tips.

Refer to [Section 1.8](#) for a list of available nozzle tip sockets.

4. Remove the nozzle tips using the nozzle tip socket.

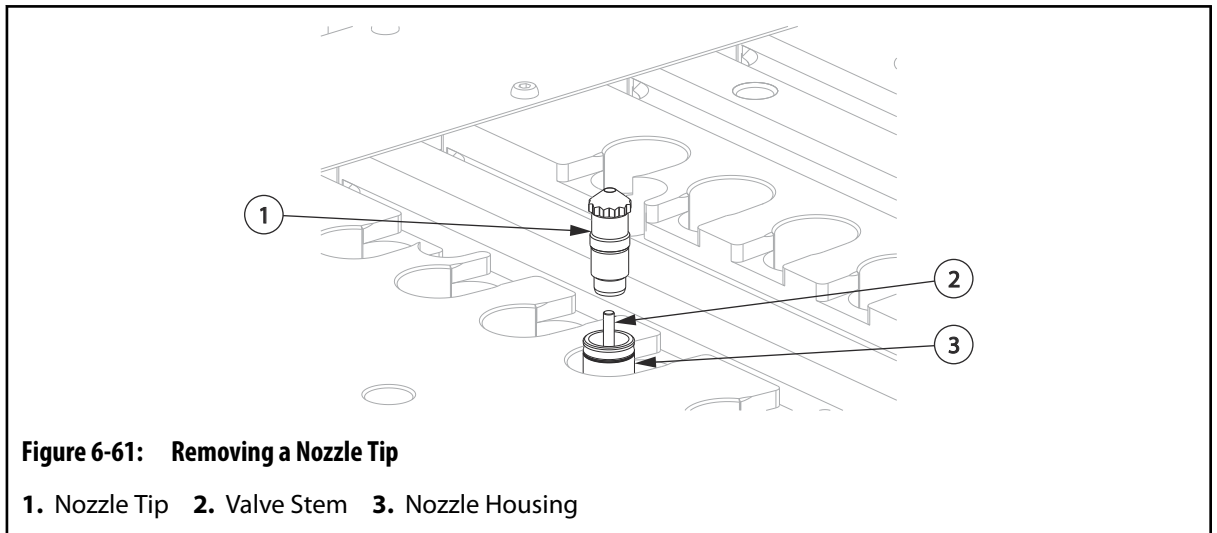

Figure 6-61: Removing a Nozzle Tip

1. Nozzle Tip 2. Valve Stem 3. Nozzle Housing

5. Remove the nozzle heaters. Refer to [Section 6.17](#) for more information.

**IMPORTANT!**

Care must be taken to prevent damage to the nozzle tip and nozzle sealing surfaces.

6. Remove any resin from the interior of the nozzle tip using a soft wire brush or equivalent.
7. Remove any resin from the interior and exterior of the nozzle housing using a soft wire brush or equivalent.

NOTE:

Do not remove locks and tags until the nozzle tips are installed.

6.14.3 Removing U750 Nozzle Tips with U1000 VG-EXX RGA Nozzles

The following procedure describes how to remove U750 nozzle tips with U1000 VG-EXX RGA nozzles.

NOTE:

Nozzle tips must be removed first, followed by the nozzle tip adapters. Whenever the nozzle tip is removed, the nozzle tip must also be removed so that the correct torque is applied when re-installed.

To remove the nozzle tips when they are hot, refer to section [Section 6.14.1](#).

To remove the nozzle tips when they are cold, refer to section [Section 6.14.2](#).

To remove the nozzle tip adapter, do the following:

1. Using an appropriate socket, loosen each nozzle tip adapter that will be removed. Refer to [Section 1.8](#) for a list of available sockets.



WARNING!

Burn hazard - risk of serious injury. To avoid serious burns, wear personal protective equipment consisting of a heat-resistant coat, heat-resistant gloves and a full face shield over safety glasses. Use adequate ventilation for fumes.

2. Wearing appropriate personal protective equipment, hand tighten each nozzle tip adapter while the resin is soft until the nozzle tip adapter touches the nozzle housing.

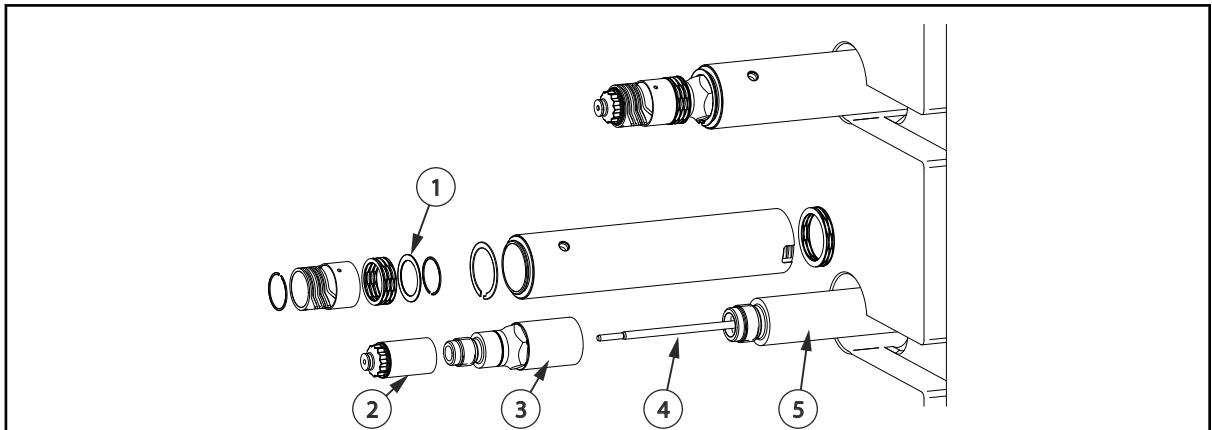

Figure 6-62: U1000 VG-EXX RGA Nozzle

1. U750 Shim 2. U750 Nozzle Tip 3. Nozzle Tip Adapter 4. Valve Stem 5. U1000 Nozzle Housing

3. Allow the nozzle tip adapters to cool to room temperature ($< 25\text{ }^{\circ}\text{C}$ ($< 77\text{ }^{\circ}\text{F}$)). This may take 1/2 to 4 hours depending on the size of the hot runner. However, this step will reduce the risk of resin solidifying on the nozzle tip sealing surfaces.
4. Remove the nozzle tip adapter using a socket or open-end wrench.

6.14.4 Installing the Nozzle Tips

To install a nozzle tip, do the following:



IMPORTANT!

Ultra Helix Valve Gate nozzle tips need to be installed after the valve stems are installed to reduce the risk of stem damage in cold condition, especially with drop locations farther away from the center of expansion. UltraHelix is especially susceptible to damage due to the smaller diameter of the Helix guiding feature.



IMPORTANT!

Make sure the Ultra Helix valve stem is installed in the closed position before fastening the nozzle tip to the nozzle housing body. This prevents the valve stem from binding in the spiraled portion of the Ultra Helix nozzle tips.



IMPORTANT!

The Ultra Helix Valve Gate nozzle heater must be removed to allow full engagement of the torque tool. The Husky supplied torque tool must be used to install the Ultra Helix nozzle tip or the tip may be damaged.

NOTE:

Nozzle tips must be installed when the resin and nozzle housings are cold.

1. Lock out and tag the machine and controller (if equipped). Refer to [Section 2.5](#) for more information.
-



IMPORTANT!

If resin or other residues are not thoroughly cleaned off the threads and seating areas of both the nozzle tip and nozzle housing, the result could lead to the following:

- Compressive overload of the tip, even at the correct torque recommendation, causing damage to the tip (permanently shortened)
 - A tip which is no longer tight after it has been heated up and cooled down
 - Poor performance or quality of the gate due to the incorrect tip position (too far back or too far forward)
 - Leakage between the nozzle tip and nozzle tip insulator, permitting the formation of degraded resin
 - Thread stripping
-

2. Remove any resin or other residue found on the nozzle tips and nozzle housings.
-

3. If the nozzle housing has an external thread, proceed to [step 4](#). Otherwise, clean the nozzle tip seating surface at the bottom of the nozzle housing bore with a soft wire brush.
4. Make sure the nozzle tip and nozzle housing are clean and dry.
5. For Ultra Helix Valve Gate, make sure the valve stem is fully forward in the closed position. The valve stem should slide smoothly into the stem guide. If there is any resistance, the guide is not properly engaged and the tip should be re-positioned or the valve stem will be damaged.
6. Using a nozzle tip socket, install the nozzle tip and torque it to the value printed on the nozzle tip. Refer to [Section 1.8](#) for a list of available nozzle tip sockets.

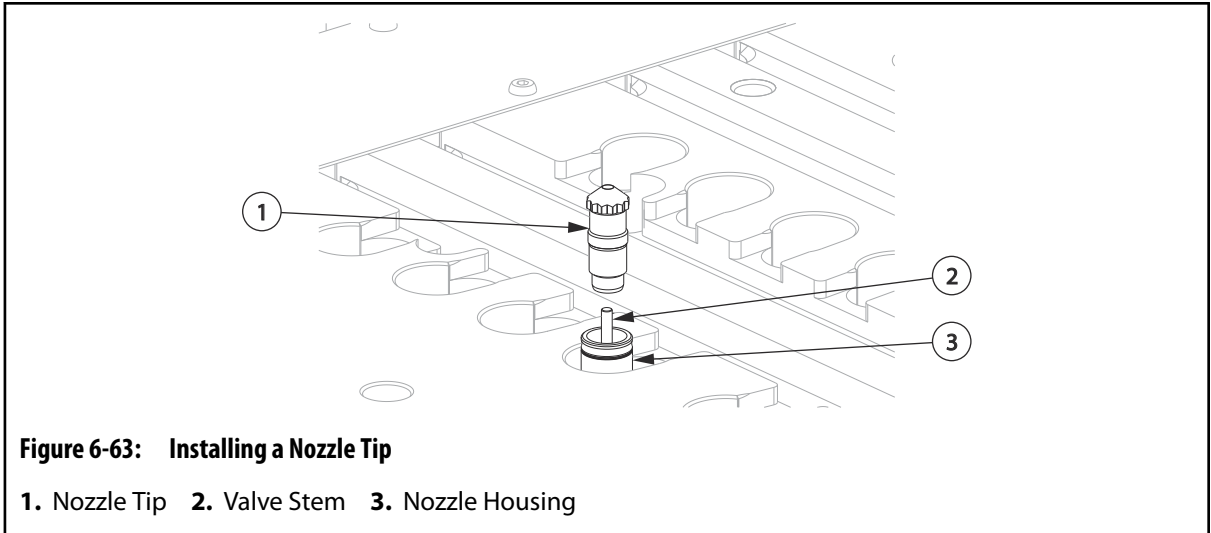

7. Install the nozzle heater. Refer to [Section 6.17](#) for more information.
8. Measure the height of the nozzle tip using a depth micrometer and compare the measurement to the tip height listed on the Tip Chart in the assembly drawings.

If the nozzle tip height is outside the tolerances listed on the Tip Chart, refer to [Section 6.14.6](#).



9. Remove all locks and tags.
10. Install the cavity plate. Refer to [Section 6.6](#) for more information.

6.14.5 Installing U750 Nozzle Tips with U1000 VG-EXX RGA Nozzles

The following procedure describes how to install U750 nozzle tips with U1000 VG-EXX RGA nozzles.

NOTE:

Install and torque the nozzle tip adapter first, then install and torque the nozzle tip. Do not install and torque them as a single unit.

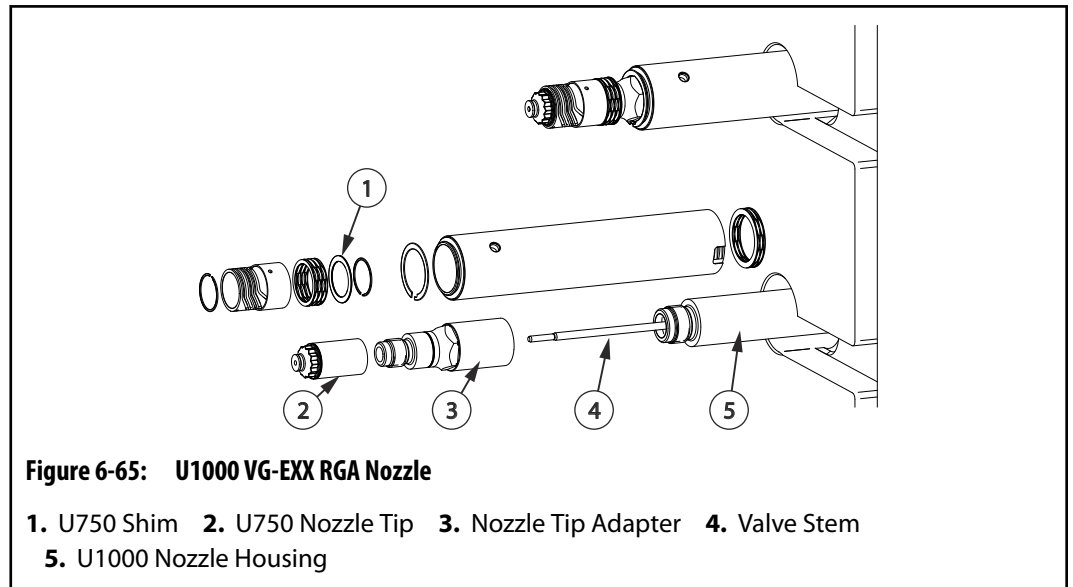

To install the nozzle tip adapter, do the following:

**IMPORTANT!**

Ultra Helix Valve Gate nozzle tips need to be installed after the valve stems are installed to reduce the risk of stem damage in cold condition, especially with drop locations farther away from the center of expansion. Ultra Helix is especially susceptible to damage due to the smaller diameter of the Helix guiding feature.

**IMPORTANT!**

Make sure the Ultra Helix valve stem is installed in the closed position before fastening the nozzle tip to the nozzle housing body. This prevents the valve stem from binding in the spiraled portion of the Ultra Helix nozzle tips.

NOTE:

Nozzle tips must be installed when the resin and nozzle housings are cold.

1. Lock out and tag the machine and controller (if equipped). Refer to [Section 2.5](#) for more information.



IMPORTANT!

If resin or other residue are not thoroughly cleaned off the threads and seating area of both the nozzle tip adapter and nozzle housing, the result could lead to the following:

- Compressive overload of the tip, even at the correct torque recommendation, causing damage to the tip (permanently shortened)
- A tip which is no longer tight after it has been heated up and cooled down
- Poor performance or quality of the gate due to the incorrect tip position (too far back or too far forward)
- Leakage between the nozzle tip, nozzle tip adapter, and nozzle tip insulator, permitting the formation of degraded resin
- Thread stripping

2. Remove any resin or other residue found on the nozzle tip, nozzle tip adapters, and nozzle housings.
3. If the nozzle housing has an external thread, proceed to [step 4](#). Otherwise, clean the nozzle tip adapter seating surface at the bottom of the nozzle housing bore with a soft wire brush.
4. Make sure the nozzle tip adapter and nozzle housings are clean and dry.
5. For Ultra Helix Valve Gate, make sure the valve stem is fully forward in the closed position. The valve stem should slide smoothly into the stem guide. If there is any resistance, the guide is not properly engaged and the tip should be re-positioned or the valve stem will be damaged.
6. Using an appropriate socket, install the nozzle tip adapter and torque it to the value printed on the adapter. Refer to [Section 1.8](#) for a list of available sockets.

To install the nozzle tips refer to [Section 6.14.4](#).

6.14.6 Troubleshooting Nozzle Tip Heights

The following describes reasons and corrective action for nozzle heights that are less or more than the values listed on the Tip Chart.

Problem	Reason	Action
Dimension is shorter than required tip height	Nozzle tip has been over-tightened, worn, or damaged	<ol style="list-style-type: none"> 1. Remove the nozzle tip 2. Clean resin from the nozzle tip and nozzle housing 3. Replace or install new nozzle tip

Problem	Reason	Action
Dimension is longer than required tip height	Nozzle tip is damaged OR Nozzle tip is being prevented from seating in the nozzle housing by resin under the nozzle tip seating surface.	<ol style="list-style-type: none"> 1. Remove the nozzle tip 2. Clean resin from the nozzle tip and nozzle housing 3. Re-apply the torque to the nozzle tip 4. Verify the nozzle tip height

6.15 Refurbishing Ultra Flow VG Nozzle Tips

To refurbish Ultra Flow VG nozzle tips, do the following:

1. Remove the nozzle tips from the nozzle assembly.
2. Thermally clean the tips by burning out the plastic (pyrolysis). Heat them at 400 °C (752 °F) for 60 minutes. Do not exceed 450 °C (842 °F) .

NOTE:

For best results, use an oven capable of heating the tips under a vacuum.

3. Allow the tips to cool, then clean the ash from the them using a small soft wire brush.
4. Allow the tips to cool, then clean the ash from the them using a small soft wire brush.
5. Visually inspect the internal surface of each tip for remaining plastic or ash.

NOTE:

A boroscope, if available, is best for this visual inspection.

6. Repeat steps 2 to 5 if any plastic remains in the tip.
7. Inspect each tip for burrs or damage.
8. Install the nozzle tips into the nozzle assembly.

NOTE:

If the tips are to be stored, coat them inside and out with anti-rust oil.

6.16 Removing and Installing Nozzle Housings

The following procedures describe how to remove, maintain and install nozzle housings.

6.16.1 Removing VG-LX and EX and SX Nozzle Housings

To remove a nozzle housing, do the following:

1. Remove the hot runner from the machine. Refer to [Section 4.3.2](#) for more information.
2. Remove the cavity plate. Refer to [Section 6.6](#) for more information.
3. Remove the nozzle tip. Refer to [Section 6.14.1](#) for more information.
4. Remove the nozzle heaters and thermocouples. Refer to [Section 6.17](#) for more information.
5. Remove the backing plate. Refer to [Section 6.7](#) for more information.
6. If equipped, remove the center plate. Refer to [Section 6.8.1](#) for more information.
7. Remove the manifolds and cross manifold (if equipped). Refer to [Section 6.9](#) for more information.

CAUTION!

Mechanical hazard – risk of damage to the hot runner. Use a brass rod to protect the manifold plate and nozzle from damage.

8. Break the resin around the nozzle housing with a side impact against the nozzle flange at the manifold face.
9. Pull the nozzle stack assembly out of the manifold pocket and disassemble.

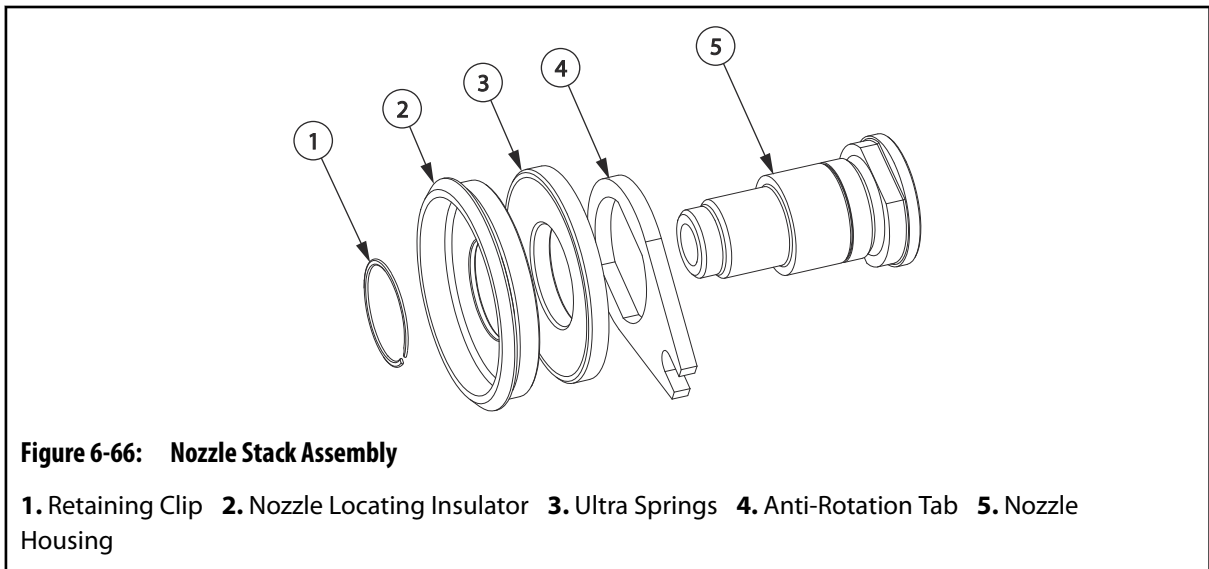

10. Inspect and clean the nozzle housing. Refer to [Section 6.16.5](#) for more information.

6.16.2 Installing VG-LX and EX and SX Nozzle Housings

To install the nozzle housings, do the following:

1. Assemble each nozzle housing.

NOTE:

Refer to the assembly drawings to verify the orientation and correct number of Ultra springs.

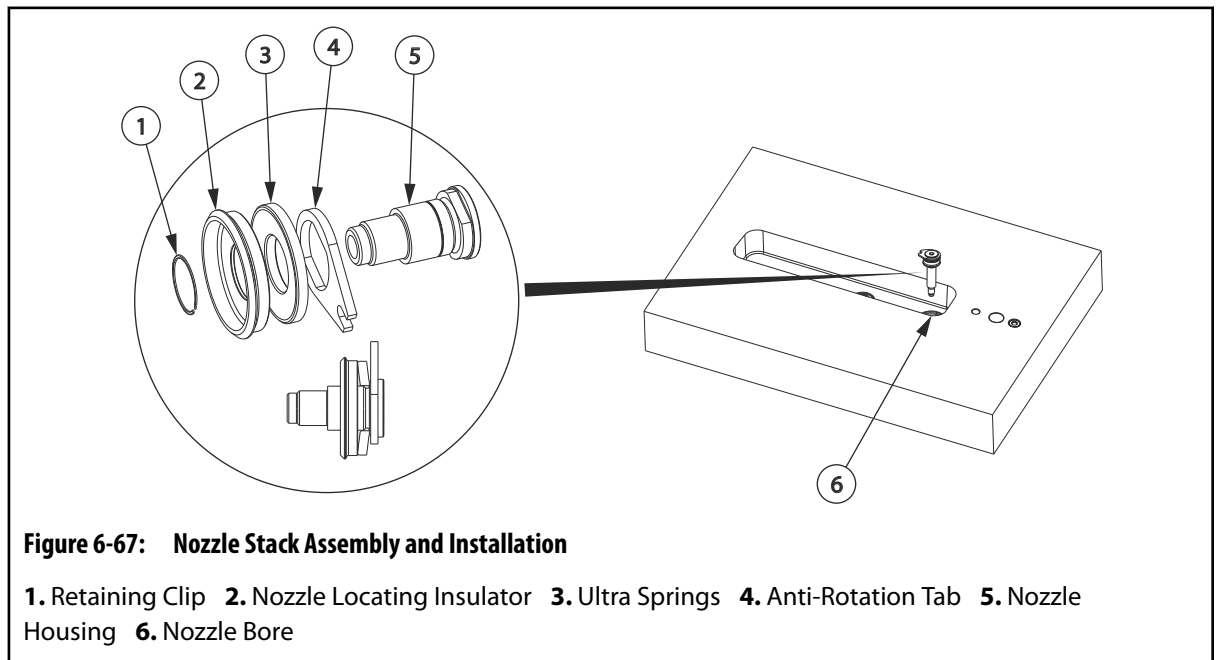

2. Place all housing assemblies into the nozzle bores in the manifold plate. Make sure the housing assemblies are properly aligned with the nozzle locating dowels to prevent rotation.
3. Install the manifolds and cross manifold (if equipped). Refer to [Section 6.9](#) for more information.
4. If equipped, install the center plate. Refer to [Section 6.8.2](#) for more information.
5. Install the backing plate. Refer to [Section 6.7](#) for more information.
6. Install the nozzle heaters and thermocouples. Refer to [Section 6.17](#) for more information.
7. Install the nozzle tip. Refer to [Section 6.14.4](#) for more information.
8. Install the cavity plate. Refer to [Section 6.6](#) for more information.
9. Install the hot runner into the machine. Refer to [Section 4.3](#) for more information.

6.16.3 Removing VG-HP and VX-HP Nozzle Housings

To remove a nozzle housing, do the following:

1. Remove the hot runner from the machine. Refer to [Section 4.3.2](#) for more information.
2. Remove the cavity plate. Refer to [Section 6.6](#) for more information.
3. Remove the nozzle tip. Refer to [Section 6.14.1](#) for more information.
4. Remove the nozzle heaters and thermocouples. Refer to [Section 6.17](#) for more information.
5. Remove the backing plate. Refer to [Section 6.7](#) for more information.
6. If equipped, remove the center plate. Refer to [Section 6.8.1](#) for more information.
7. Remove the manifolds and cross manifold (if equipped). Refer to [Section 6.9](#) for more information.

CAUTION!

Mechanical hazard – risk of damage to the hot runner. Use a brass rod to protect the manifold plate and nozzle from damage.

8. Break the resin around the nozzle housing with a side impact against the nozzle flange at the manifold face.
9. Pull the nozzle stack assembly out of the manifold pocket and disassemble.

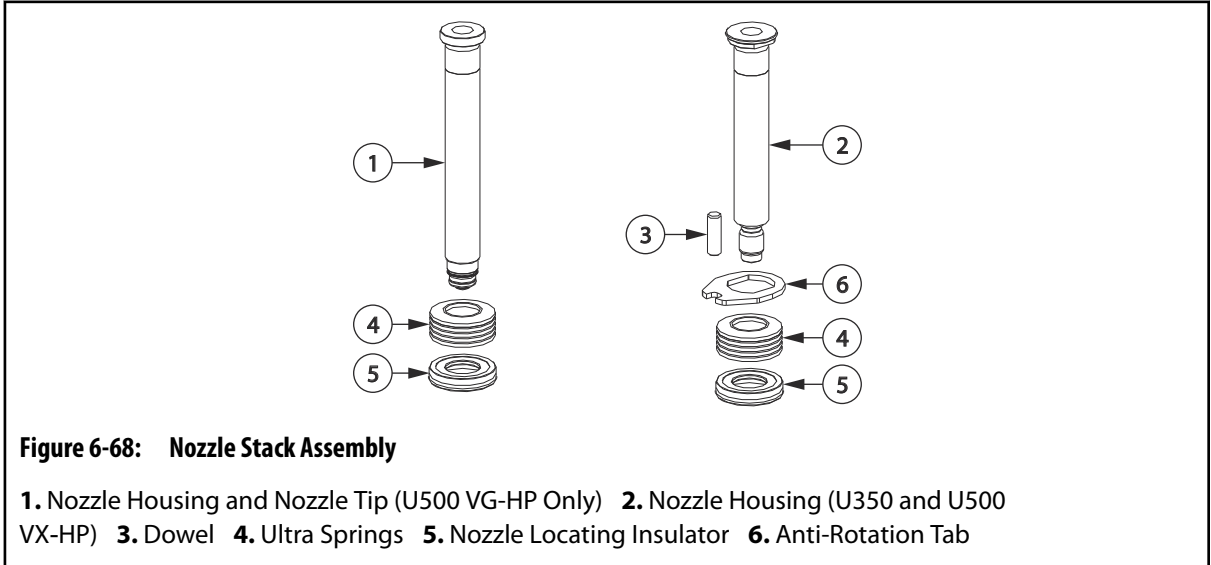

10. Inspect and clean the nozzle housing. Refer to [Section 6.16.5](#) for more information.

6.16.4 Installing VG-HP and VX-HP Nozzle Housings

To install the nozzle housings, do the following:

1. Assemble each nozzle housing.

NOTE:

Refer to the assembly drawings to verify the orientation and correct number of Ultra springs.

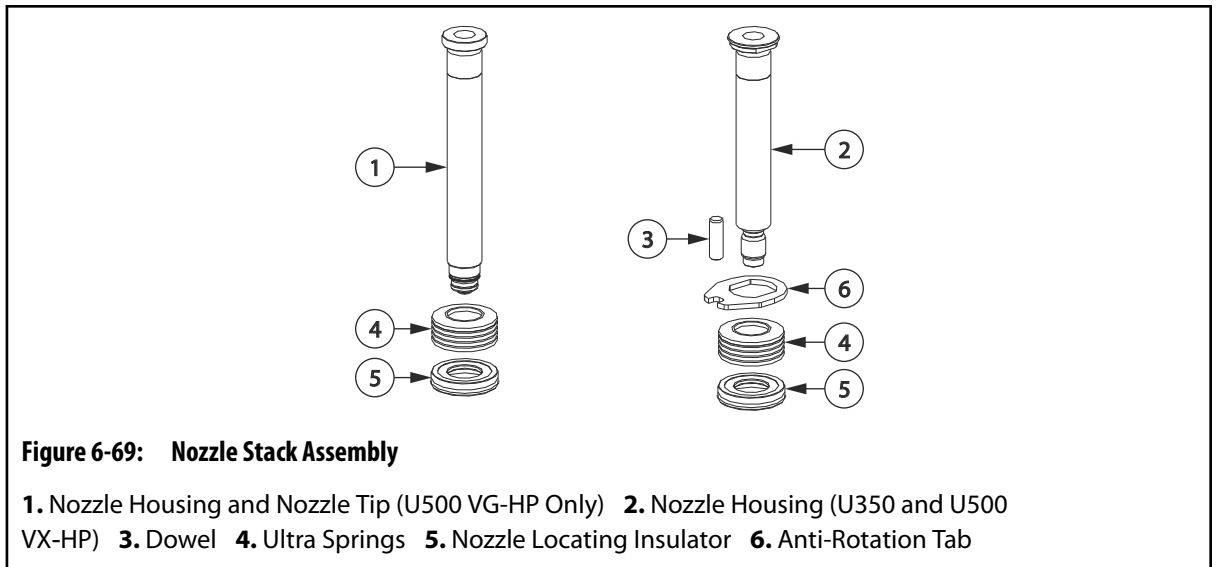

2. Place all housing assemblies into the nozzle bores in the manifold plate. Make sure the housing assemblies are properly aligned with the nozzle locating dowels to prevent rotation.
3. Install the manifolds and cross manifold (if equipped). Refer to [Section 6.9](#) for more information.
4. If equipped, install the center plate. Refer to [Section 6.8.2](#) for more information.
5. Install the backing plate. Refer to [Section 6.7.2](#) for more information.
6. Install the nozzle tip. Refer to [Section 6.14.4](#) for more information.
7. Install the nozzle heaters and thermocouples. Refer to [Section 6.17](#) for more information.
8. Install the cavity plate. Refer to [Section 6.6](#) for more information.

6.16.5 Inspecting and Cleaning Nozzle Housings

To inspect and clean the nozzle housings after they have been removed, do the following:

CAUTION!

Mechanical hazard – risk of equipment damage. Do not hone the back surface of the nozzle housing to remove nicks and burrs. The back surface is a precision made section of the housing with a contoured surface. Honing this section will cause the system to leak and void the leak proof guarantee for the hot runner.

1. Inspect all nozzle stack components for damage or wear. Replace as necessary.
2. If the nozzle housing has an internal thread, clean the nozzle tip seating surface at the bottom of the nozzle housing bore. This step is not required for nozzle housings that have an external thread.
3. Clean the thread with a soft wire brush.
4. Remove all resin from the melt channel in the nozzle housing.
5. Remove all resin from the nozzle housing bore in the manifold plate.

6.17 Removing and Installing Nozzle Heaters

The following procedures describe how to remove and install nozzle heaters. The following types of nozzle heaters are supported:



IMPORTANT!

Husky nozzle heaters are rugged and have a long service life. Only replace nozzle heaters with Husky approved parts. Use of components not sold or approved by Husky will void the hot runner warranty.

- HTM heaters for U350, U500 and U750 systems
- HTM heaters for U1000 systems
- Copper heaters for U500 systems
- Ultra Nozzle Heaters (UNH) with front rings for U500 and U750 systems
- Ultra Nozzle Heaters (UNH) with ring thermocouples for U500 and U750 systems
- Bi-metal heaters for U500, U750 and U1000 systems
- VG-HP heaters for U500 systems

6.17.1 Removing and Installing HTM Nozzle Heaters for U350, U500 and U750 Systems

The following procedures describe how to remove and install HTM nozzle heaters for U350, U500 and U750 systems.

6.17.1.1 Removing HTM Nozzle Heaters for U350, U500 and U750 Systems

To remove an HTM nozzle heater, do the following:

1. Separate or remove the cavity plate from the hot runner. Refer to [Section 6.6](#) for more information.
2. Remove the retaining clip from the nozzle tip.

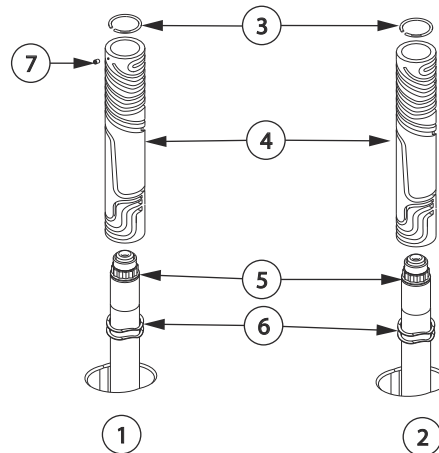

Figure 6-70: HTM Nozzle Heater Assembly

1. HTM Heater with Set Screw **2.** HTM Heater without Set Screw **3.** Retaining Clip **4.** HTM Nozzle Heater **5.** Nozzle Tip **6.** Wave Springs **7.** Set Screw

- 3.** Remove the necessary wire clips to expose the nozzle heater and thermocouple wires.

NOTE:

The nozzle heater assembly includes the retaining sleeve, nozzle heater and thermocouple.

- 4.** Remove retaining set screw on the heater sleeve, if applicable.
- 5.** Remove the nozzle heater assembly.
- 6.** Remove and discard the wave springs.

6.17.1.2 Installing HTM Nozzle Heaters for U350, U500 and U750 Systems

To install an HTM nozzle heater for U350, U500 and U750 systems, do the following:

- 1.** Install new wave springs over the nozzle housing and nozzle tip.

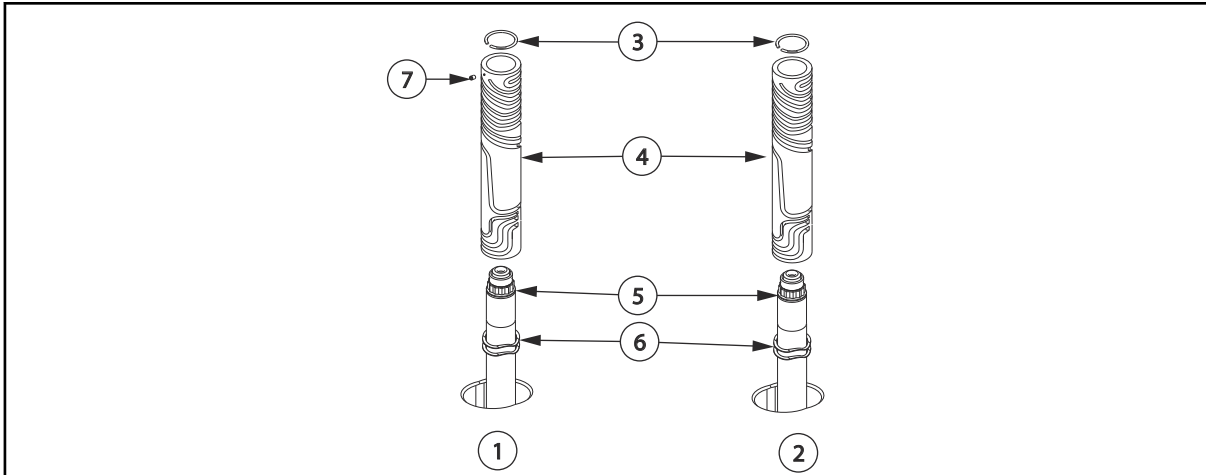

Figure 6-71: HTM Nozzle Heater Assembly

1. HTM Heater with Set Screw 2. HTM Heater without Set Screw 3. Retaining Clip 4. HTM Nozzle Heater 5. Nozzle Tip 6. Wave Springs 7. Set Screw

2. Slide the nozzle heater assembly over the nozzle housing far enough to show the retaining clip groove on the nozzle tip.
3. Install the retaining clip on the nozzle tip and pull the nozzle heater assembly up against it.
4. Install the set screw, if applicable.
5. Route the nozzle heater and thermocouple wires through the wire channels in the manifold plate. Make sure all wiring is properly retained in the wire channels using wire clips.
6. Make sure to stagger the knuckles in the wire grooves.



Figure 6-72: Staggering the Knuckles in the Wire Grooves

NOTE:

All wire, including heater or thermocouple wire, that could contact a heated component such as a nozzle housing or manifold must be mineral insulated high temperature wire (hard lead). If the mineral insulated lead is not long enough to allow this, additional steps must be taken, such as using high temperature sleeving, to prevent the knuckles and PTFE or Kapton insulated wire (soft lead) from overheating.

7. Label each wire with the heater zone number. Refer to the electrical schematic for the zone number.
8. Crimp the wire ends and connect the wires to the appropriate multi-pin connectors. Refer to the electrical schematic for more information.
9. Test each nozzle heater. Refer to [Section 6.5](#) for more information.
10. Install the cavity plate. Refer to [Section 6.6](#) for more information.

6.17.2 Removing and Installing HTM Nozzle Heaters for U1000 Systems

The following procedures describe how to remove and install HTM nozzle heaters for U1000 systems.

6.17.2.1 Removing HTM Nozzle Heaters for U1000 Systems

To remove the HTM nozzle heaters for a U1000 system, do the following:

1. Separate or remove the cavity plate from the hot runner. Refer to [Section 6.6](#) for more information.
2. Remove the retaining clip from the nozzle tip.

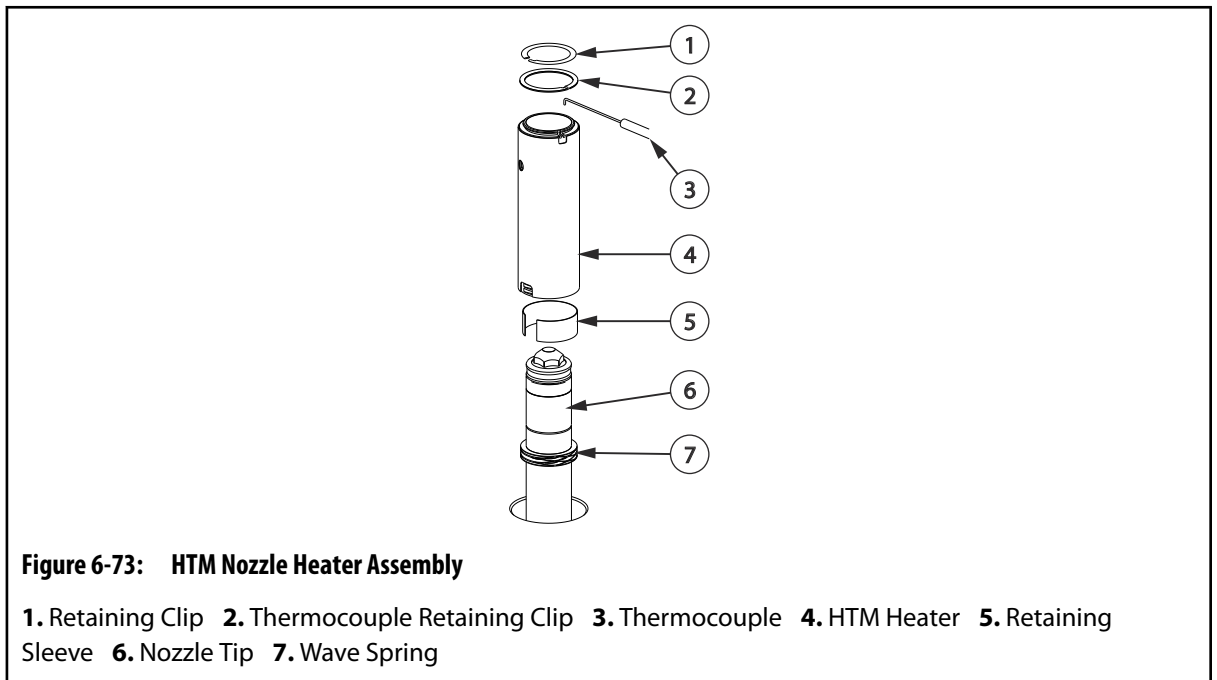

3. Remove the retaining sleeve, if applicable.
4. Remove the necessary wire clips to expose the nozzle heater and thermocouple wires.

NOTE:

The nozzle heater assembly includes the retaining sleeve, nozzle heater and thermocouple.

5. Remove the thermocouple retaining clip from the nozzle heater.
6. Disconnect the thermocouple from the nozzle heater.
7. Remove the nozzle heater and thermocouple.
8. Remove and discard the wave springs.

6.17.2.2 Installing HTM Nozzle Heaters for U1000 Systems

To install an HTM heater for a U1000 system, do the following:

1. Install new wave springs over the nozzle housing and nozzle tip.

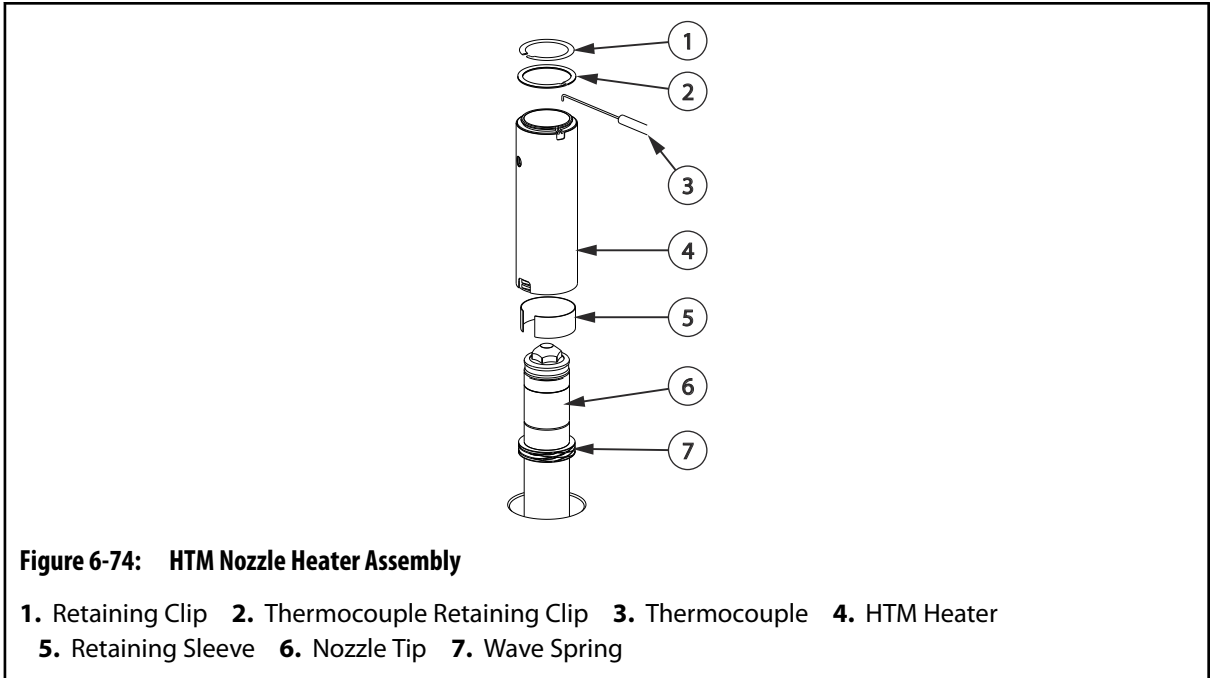

2. Slide the nozzle heater assembly over the nozzle housing.
3. Insert the tip of the thermocouple with a downward motion into one of the thermocouple probe holes.



IMPORTANT!

Make sure that the tip of the thermocouple is pressed all the way down into the hole in the heater body. This will help to secure the thermocouple effectively.

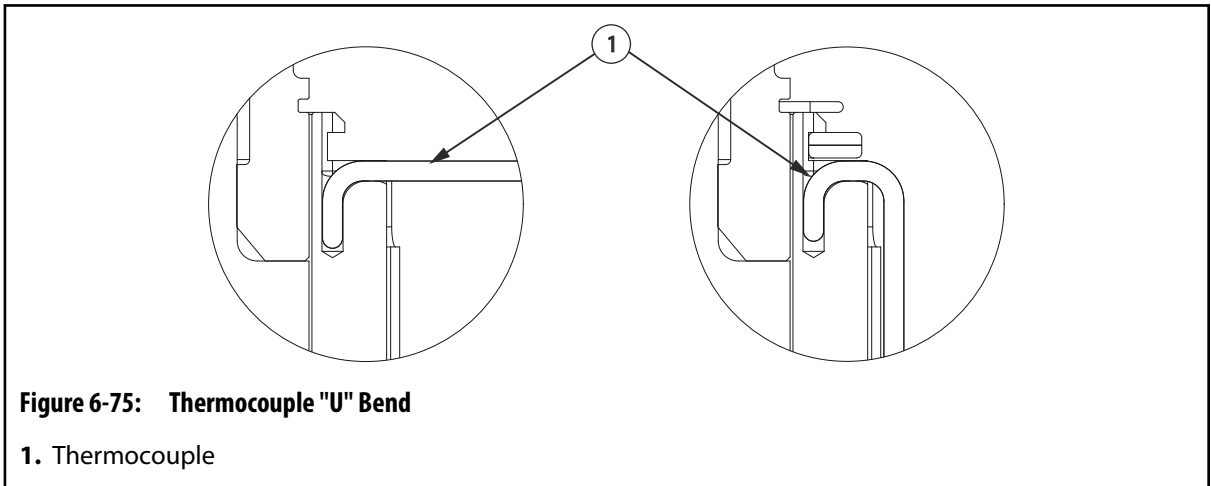

4. Install the thermocouple retaining clip on the nozzle heater.
5. Install the retaining clip on the nozzle tip.
6. Bend the thermocouple so it is tight to the heater body (the end of the thermocouple should now be bent in a U-shape).

7. Install the retaining sleeve over the nozzle heater and thermocouple, if applicable.
8. Route the nozzle heater and thermocouple wires through the wire channels in the manifold plate. Make sure all wiring is properly retained in the wire channels using wire clips.
9. Pull the heater away from the retaining clip and release it. Make sure the heater moves back into place and contacts the retaining clip.
10. Make sure to stagger the knuckles in the wire grooves.



Figure 6-76: Staggering the Knuckles in the Wire Grooves

NOTE:

All wire, including heater or thermocouple wire, that could contact a heated component such as a nozzle housing or manifold must be mineral insulated high temperature wire (hard lead). If the mineral insulated lead is not long enough to allow this, additional steps must be taken, such as using high temperature sleeving, to prevent the knuckles and PTFE or Kapton insulated wire (soft lead) from overheating.

-
11. Label each wire with the heater zone number. Refer to the electrical schematic for the zone number.
 12. Crimp the wire ends and connect the wires to the appropriate multi-pin connectors. Refer to the electrical schematic for more information.
 13. Test each nozzle heater. Refer to [Section 6.5](#) for more information.
 14. Install the cavity plate. Refer to [Section 6.6](#) for more information.

6.17.3 Removing and Installing Copper Nozzle Heaters

The following procedures describe how to remove and install copper nozzle heaters.

6.17.3.1 Removing Copper Nozzle Heaters

To remove a copper nozzle heater, do the following:

1. Separate or remove the cavity plate from the hot runner. Refer to [Section 6.6](#) for more information.
2. Remove the front ring.

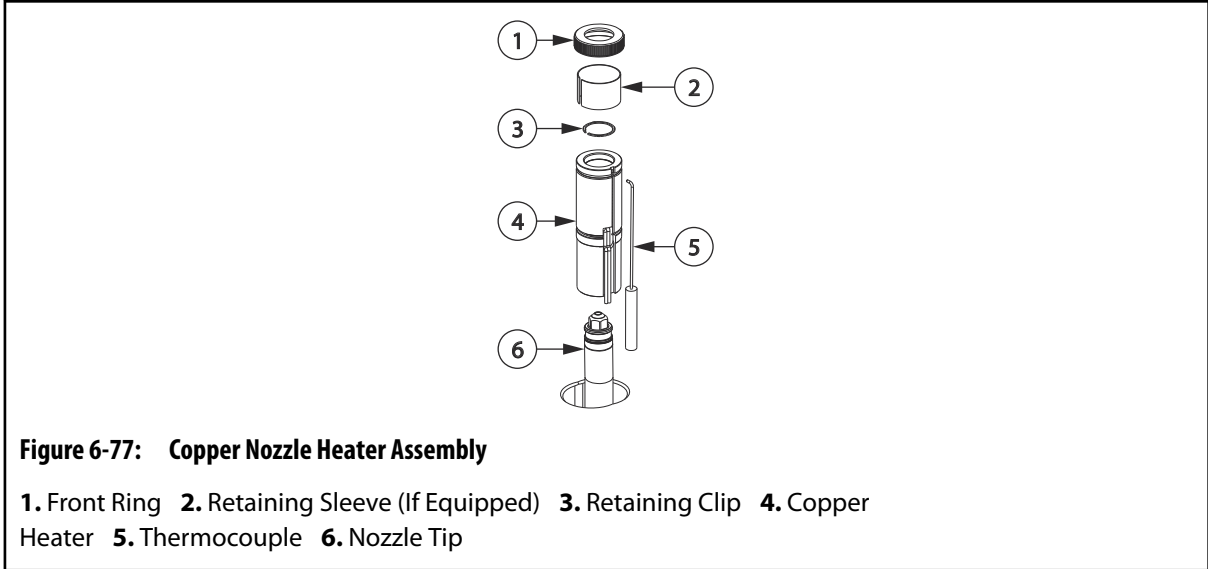

3. If equipped, remove the retaining sleeve.
4. Disconnect the thermocouple from the nozzle heater.
5. Remove the retaining clip from the nozzle tip.
6. Remove the necessary wire clips to expose the nozzle heater and thermocouple wires.
7. Remove the nozzle heater and thermocouple.

6.17.3.2 Installing Copper Nozzle Heaters

To install a copper nozzle heater, do the following:

1. Slide the nozzle heater over the nozzle housing and nozzle tip.

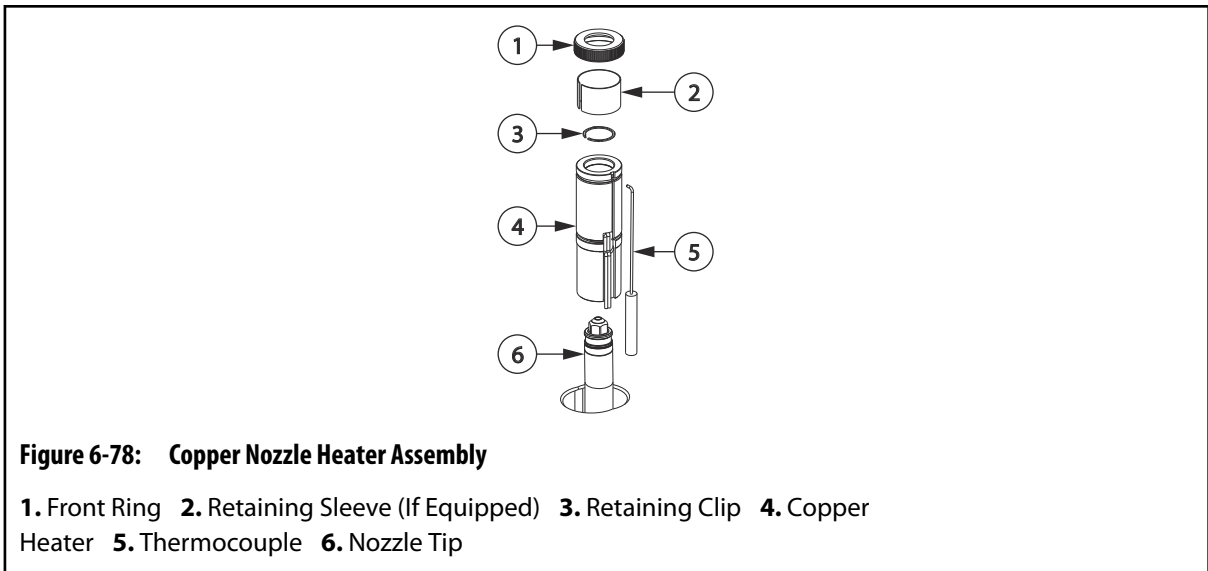

2. Install the retaining clip around the nozzle tip.
3. Connect the thermocouple to the nozzle heater.
4. Pull the nozzle heater up against the retaining clip.
5. If equipped, install the retaining sleeve over the nozzle heater and thermocouple.

6. Install the front ring and tighten by hand.
7. Route the nozzle heater and thermocouple wires through the wire grooves in the manifold plate. Make sure all wiring is properly retained in the wire grooves using wire clips.
8. Make sure to stagger the knuckles in the wire grooves.



Figure 6-79: Staggering the Knuckles in the Wire Grooves

NOTE:

All wiring along the nozzle heater must be either a high temperature braid or sleeved using a high temperature sleeving.

9. Label each wire with the heater zone number. Refer to the electrical schematic for the zone number.
10. Crimp the wire ends and connect the wires to the appropriate multi-pin connectors. Refer to the electrical schematic for more information.
11. Test each nozzle heater zone. Refer to [Section 6.5](#) for more information.

6.17.4 Removing and Installing Ultra Nozzle Heaters With Front Rings (UNH 500 and 750)

The following procedures describe how to remove and install ultra nozzle heaters with front rings.

6.17.4.1 Removing Ultra Nozzle Heaters (UNH) With Front Rings

To replace an Ultra Nozzle Heater (UNH) with a front ring, do the following:

1. Separate or remove the cavity plate from the hot runner. Refer to [Section 6.6](#) for more information.
2. Remove the front ring.

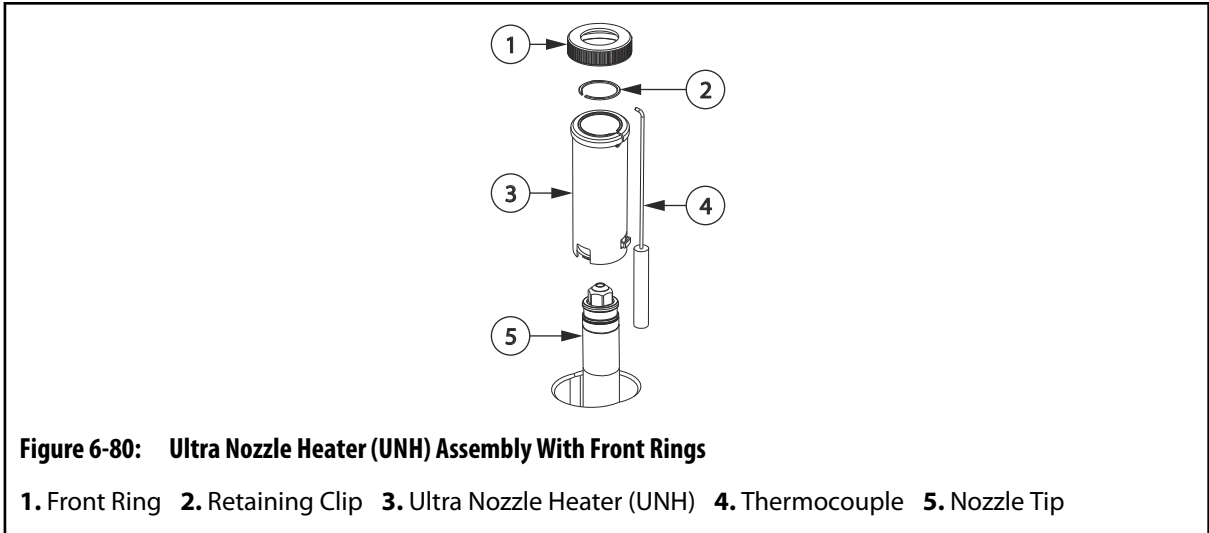

3. Disconnect the thermocouple from the nozzle heater.
4. Remove the retaining clip from the nozzle tip.
5. Remove the necessary wire clips to expose the nozzle heater and thermocouple wires.
6. Remove the nozzle heater and thermocouple.

6.17.4.2 Installing Ultra Nozzle Heaters (UNH) with Front Rings

To install an Ultra Nozzle Heater (UNH) with a front ring, do the following:

1. Slide the nozzle heater over the nozzle housing and nozzle tip.

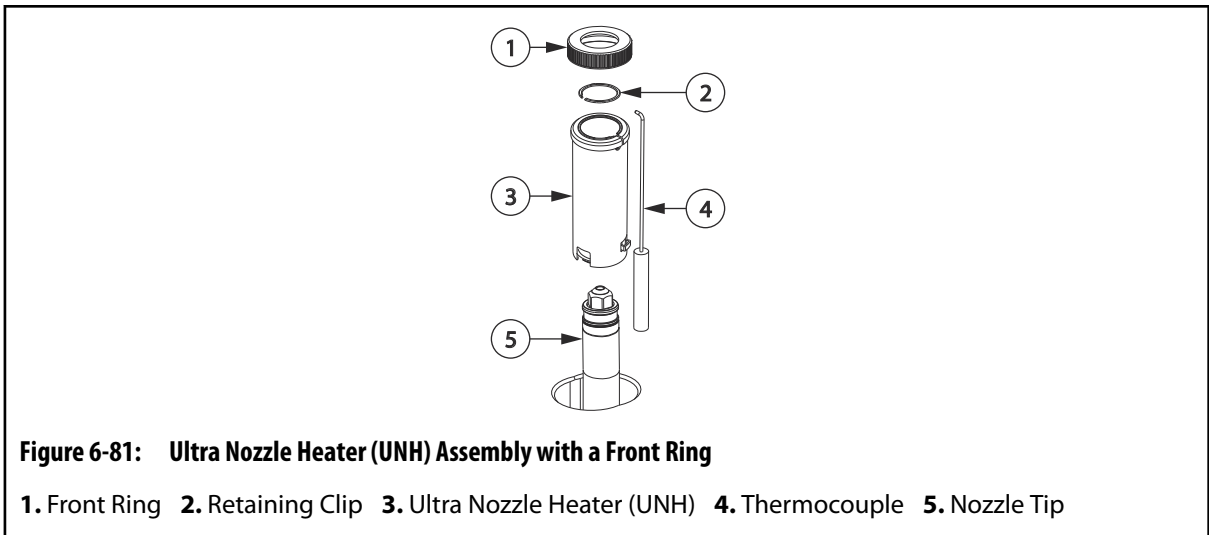

2. Install the retaining clip around the nozzle tip.
3. Connect the thermocouple to the nozzle heater.
4. Pull the nozzle heater up against the retaining clip.
5. Install the front ring and tighten by hand.

CAUTION!

Mechanical hazard – risk of damage to the hot runner. Do not bend the nozzle heater wires at a 90° angle. Do not bend the nozzle heater wires directly at the lead exit of the heater body. The wires will crack or break over time.

6. On the U750 heaters, bend the nozzle heater wires in an arc against the heater body. Make sure each bend has a minimum 10 mm (0.4 in) radius.

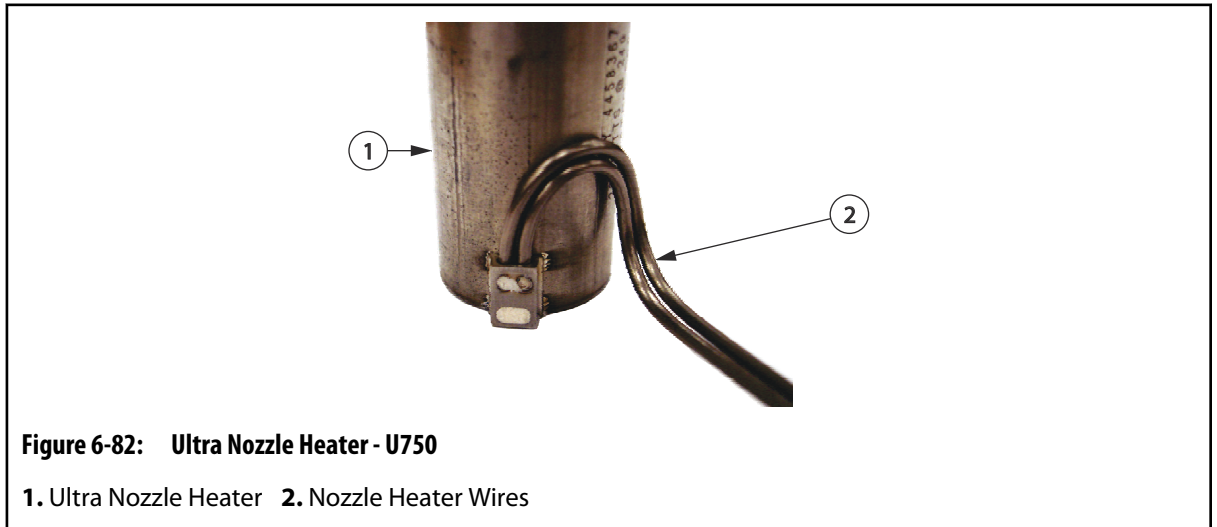

7. On U500 heaters, first bend the leads along the curvature of the heater, and then bend them up or down (away from the lead exit of the heater body) to meet the manifold plate wire groove as required.

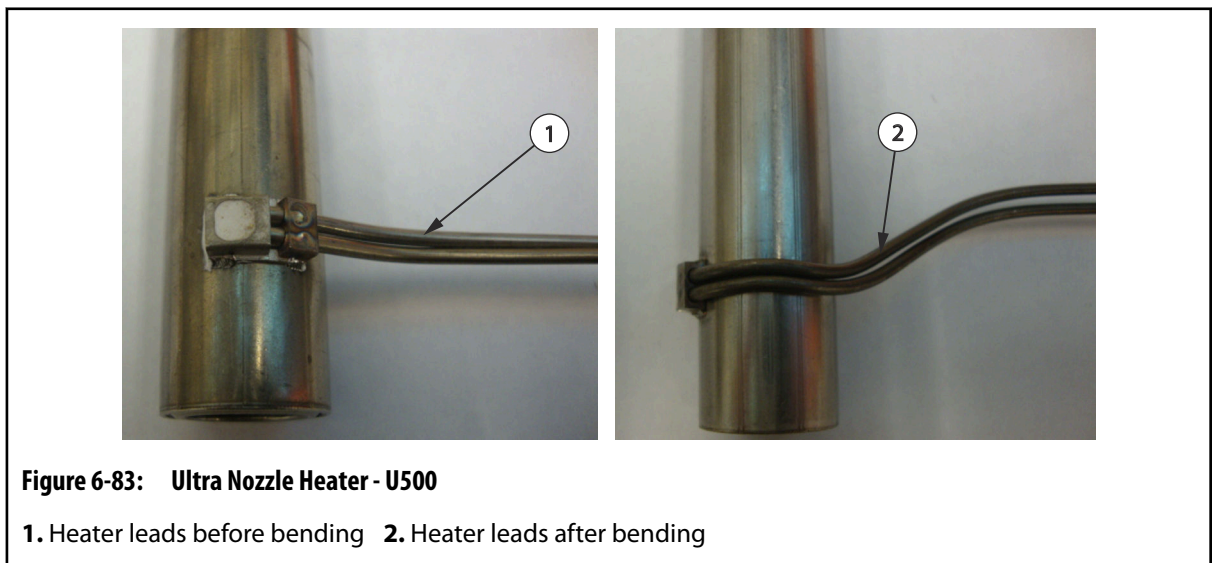

8. Route the nozzle heater and thermocouple wires through the wire channels in the manifold plate. Make sure all wiring is properly retained in the wire channels using wire clips.
9. Make sure to stagger the knuckles in the wire grooves.



Figure 6-84: Staggering the Knuckles in the Wire Grooves

NOTE:

All wire, including heater or thermocouple wire, that could contact a heated component such as a nozzle housing or manifold must be mineral insulated high temperature wire (hard lead). If the mineral insulated lead is not long enough to allow this, additional steps must be taken, such as using high temperature sleeving, to prevent the knuckles and PTFE or Kapton insulated wire (soft lead) from overheating.

10. Label each wire with the heater zone number. Refer to the electrical schematic for the zone number.
11. Crimp the wire ends and connect the wires to the appropriate multi-pin connectors. Refer to the electrical schematic for more information.
12. Test each nozzle heater. Refer to [Section 6.5](#) for more information.

6.17.5 Removing and Installing Ultra Nozzle Heaters (UNH) With Ring Thermocouples

The following procedures describe how to remove and install ultra nozzle heaters with ring thermocouples (UNH 500 and UNH 750).

6.17.5.1 Removing Ultra Nozzle Heaters (UNH) With Ring Thermocouples

To replace an Ultra Nozzle Heater (UNH) with a ring thermocouple, do the following:

1. Separate or remove the cavity plate from the hot runner. Refer to [Section 6.6](#) for more information.
2. Remove the retaining clip from the nozzle tip.
3. Remove the necessary wire clips to expose the nozzle heater and thermocouple wires.
4. Remove the ring thermocouple.

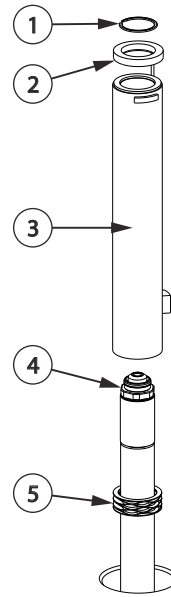

Figure 6-85: Ultra Nozzle Heater (UNH) Assembly With a Ring Thermocouple

1. Retaining Clip 2. Ring Thermocouple 3. Ultra Nozzle Heater (UNH) 4. Nozzle Tip
5. Wave Spring

5. Using the UNH heater removal tool, remove the nozzle heater.
6. Remove and discard the wave springs.

6.17.5.2 Installing Ultra Nozzle Heaters (UNH) With Ring Thermocouples

To install an Ultra Nozzle Heater (UNH) with a ring thermocouple, do the following:

1. Install new wave springs over the nozzle housing and nozzle tip.

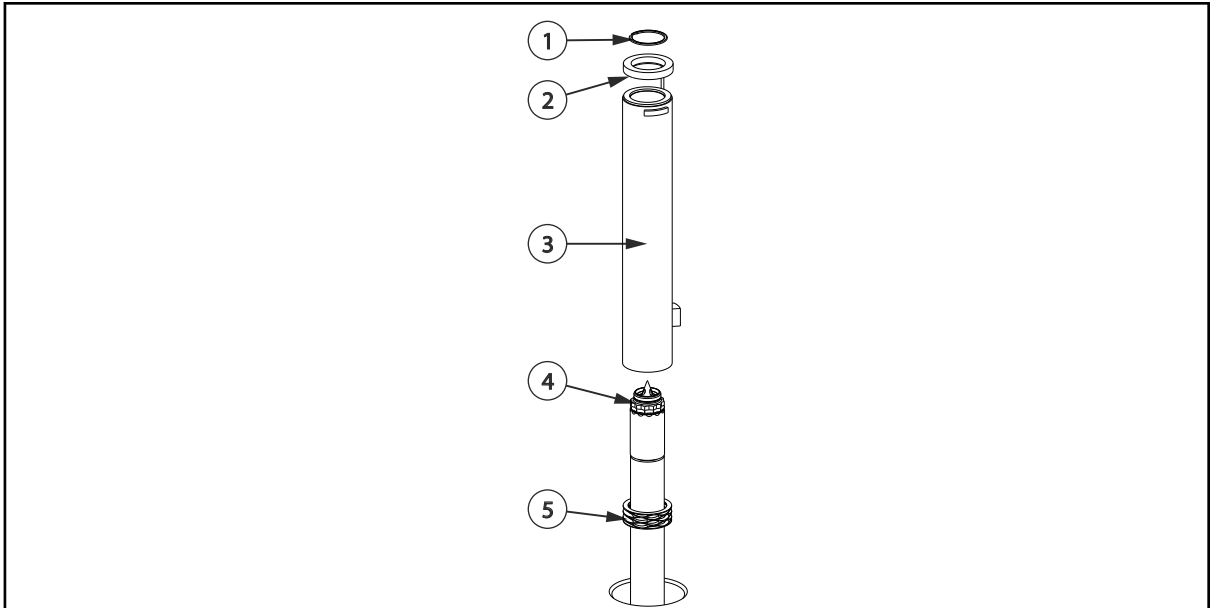

Figure 6-86: Ultra Nozzle Heater (UNH) Assembly With a Ring Thermocouple

- 1. Retaining Clip 2. Ring Thermocouple 3. Ultra Nozzle Heater (UNH) 4. Nozzle Tip
- 5. Wave Spring

- 2. Slide the nozzle heater over the nozzle housing far enough to show the retaining clip groove on the nozzle tip.
- 3. Slide the ring thermocouple over the nozzle tip, on to the nozzle heater, far enough to show the retaining clip groove on the nozzle tip.
- 4. Install the retaining clip on the nozzle tip and pull the nozzle heater and ring thermocouple up against it.



IMPORTANT!

Make sure the retaining ring is snapped fully into the retaining clip groove around the whole diameter of the nozzle tip. Refer to the following figure.

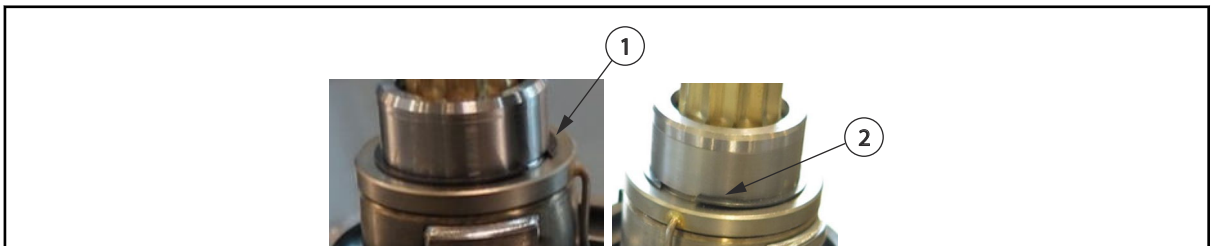

Figure 6-87: Retaining Ring in Nozzle Tip Groove

- 1. Retaining Clip Fully Seated in Groove (Correct)
- 2. Retaining Clip Not Fully Seated in Groove (Incorrect)

CAUTION!

Mechanical hazard – risk of damage to the hot runner. Do not bend the nozzle heater wires at a 90° angle. Do not bend the nozzle heater wires directly at the lead exit of the heater body. The wires will crack or break over time.

5. On U750 heaters, bend the nozzle heater wires in an arc against the heater body. Make sure each bend has a minimum 10 mm (0.4 in) radius.

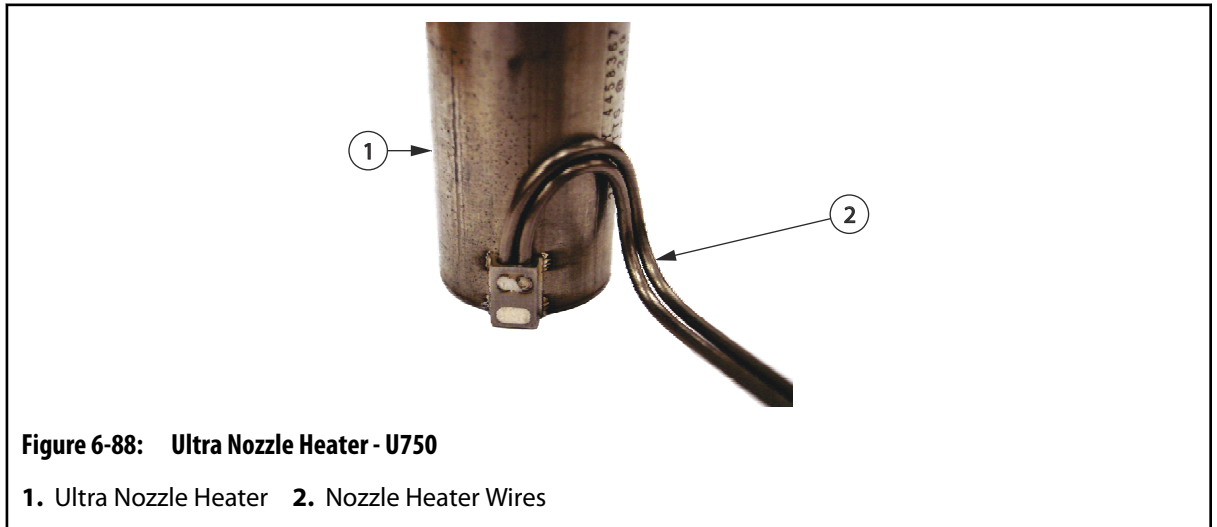

6. On U500 heaters, first bend the leads along the curvature of the heater, and then bend them up or down (away from the lead exit of the heater body) to meet the manifold plate wire groove as required.

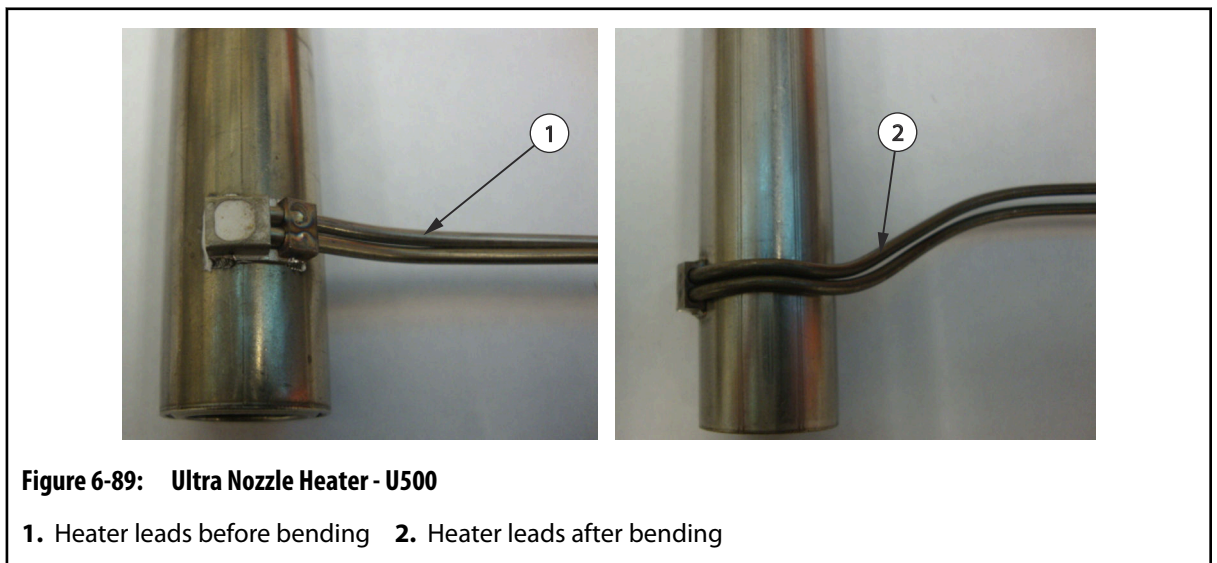

7. Route the nozzle heater and thermocouple wires through the wire channels in the manifold plate. Make sure all wiring is properly retained in the wire channels using wire clips. Make sure of the following:
 - a. Wiring does not protrude above the plate surface.

- b.** The heater and thermocouple spring back to the retaining ring and maintain contact with each other after being pushed down (0.5 to 2mm) on the housing. See the following figure.

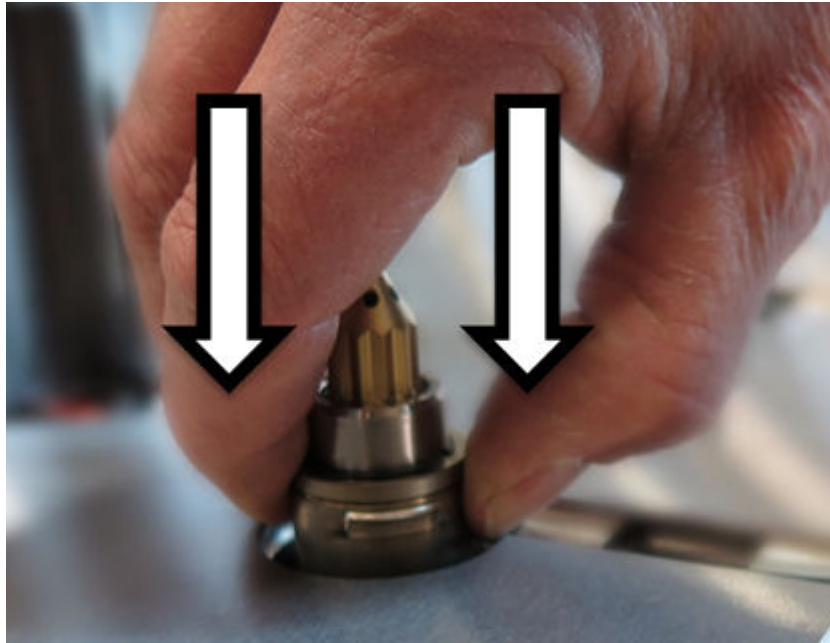

Figure 6-90: Heater/ Thermocouple Spring Back to Retaining Ring

NOTE:

If the heater and thermocouple do not spring back to the snap ring or maintain contact with each other, the bends in the wiring may be at fault.

- Wire routing must not over constrain heater positioning on nozzle.
- Wiring contacting a wire groove clip can restrict spring-back motion.
- Adjust wiring by pushing it down towards the bottom of the wire groove.
- Wiring must not protrude above the plate surface.

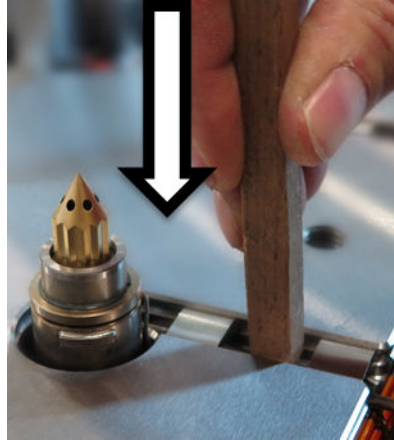

Figure 6-91: Wiring Placement in Groove

NOTE:

Proper operation of the Ultra Nozzle Heater requires the force of the wave spring to maintain contact between the thermocouple ring and nozzle heater. Improper installation may result in processing issues.

8. Make sure to stagger the knuckles in the wire grooves.



Figure 6-92: Staggering the Knuckles in the Wire Grooves

NOTE:

All wire, including heater or thermocouple wire, that could contact a heated component such as a nozzle housing or manifold must be mineral insulated high temperature wire (hard lead). If the mineral insulated lead is not long enough to allow this, additional steps must be taken, such as using high temperature sleeving, to prevent the knuckles and PTFE or Kapton insulated wire (soft lead) from overheating.

9. Label each wire with the heater zone number. Refer to the electrical schematic for the zone number.

10. Crimp the wire ends and connect the wires to the appropriate multi-pin connectors. Refer to the electrical schematic for more information.
11. Test each nozzle heater. Refer to [Section 6.5](#) for more information.
12. Remove all locks and tags. Refer to [Section 2.5](#) for more information.

6.17.6 Removing and Installing Bi-Metal Nozzle Heaters

The following procedures describe how in remove and install bi-metal nozzle heaters.

6.17.6.1 Removing Bi-Metal Nozzle Heaters

To replace a bi-metal nozzle heater, do the following:

1. Separate or remove the cavity plate from the hot runner. Refer to [Section 6.6](#) for more information.
2. Remove the front ring.

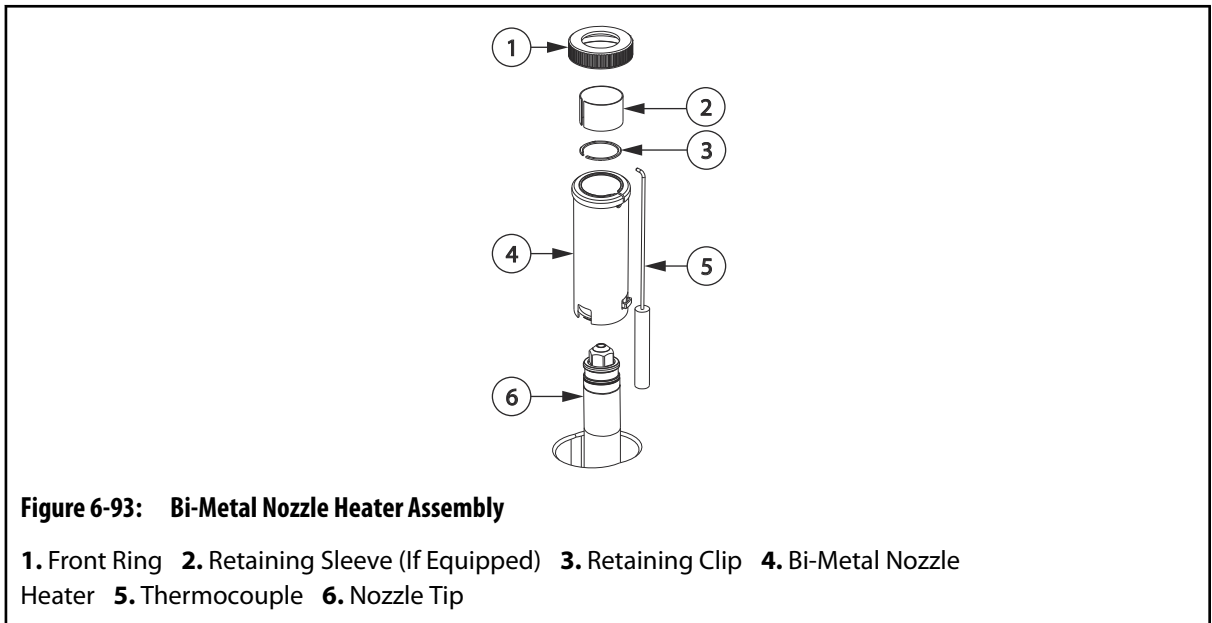

3. Disconnect the thermocouple from the nozzle heater.
4. Remove the retaining clip from the nozzle tip.
5. Remove the necessary wire clips to expose the nozzle heater and thermocouple wires.
6. Remove the nozzle heater and thermocouple.

6.17.6.2 Installing Bi-Metal Nozzle Heaters

To install a bi-metal nozzle heater, do the following:

1. Slide the nozzle heater over the nozzle housing and nozzle tip.

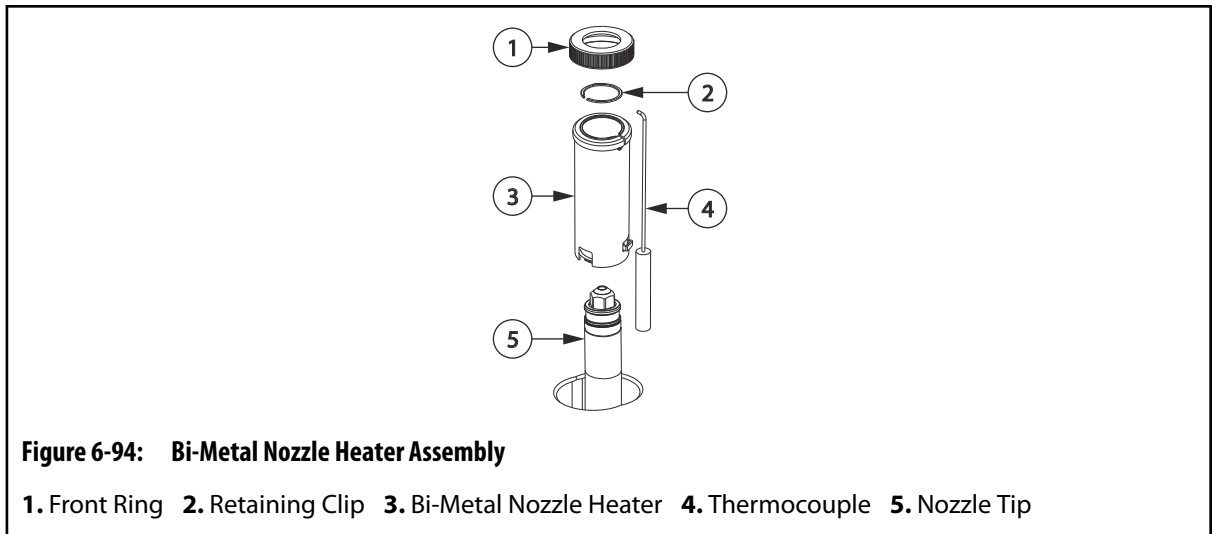

2. Install the retaining clip around the nozzle tip.
3. Connect the thermocouple to the nozzle heater.
4. Pull the nozzle heater up against the retaining clip.
5. Install the front ring and tighten by hand.
6. Route the nozzle heater and thermocouple wires through the wire channels in the manifold plate. Make sure all wiring is properly retained in the wire channels using wire clips.
7. Make sure to stagger the knuckles in the wire grooves.



NOTE:

All wire, including heater or thermocouple wire, that could contact a heated component such as a nozzle housing or manifold must be mineral insulated high temperature wire (hard lead). If the mineral insulated lead is not long enough to allow this, additional steps must be taken, such as using high temperature sleeving, to prevent the knuckles and PTFE or Kapton insulated wire (soft lead) from overheating.

8. Label each wire with the heater zone number. Refer to the electrical schematic for the zone number.
9. Crimp the wire ends and connect the wires to the appropriate multi-pin connectors. Refer to the electrical schematic for more information.
10. Test each nozzle heater. Refer to [Section 6.5](#) for more information.

6.17.7 Removing and Installing VG-HP Nozzle Heaters

The following procedures describe how to remove and install VG-HP nozzle heaters.

6.17.7.1 Removing VG-HP Nozzle Heaters

To remove a VG-HP nozzle heater, do the following:

1. Separate or remove the cavity plate from the hot runner Refer to [Section 6.6](#). for more information.
2. Remove the retaining clip from the nozzle tip.

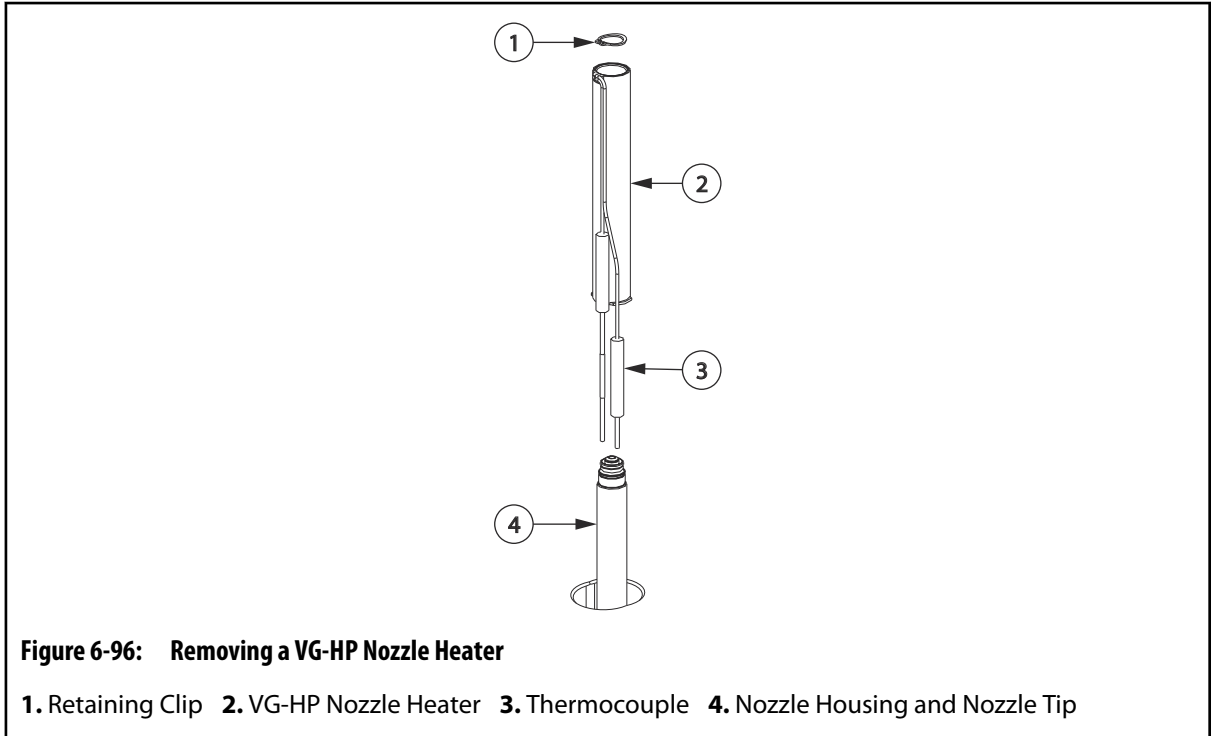

3. Remove the necessary wire clips to expose the thermocouple wires.
4. Remove the nozzle heater and thermocouple.

6.17.7.2 Installing VG-HP Nozzle Heaters

To install a VG-HP nozzle heater, do the following:

1. Slide the nozzle heater assembly over the nozzle housing far enough to show the retaining clip groove on the nozzle tip.

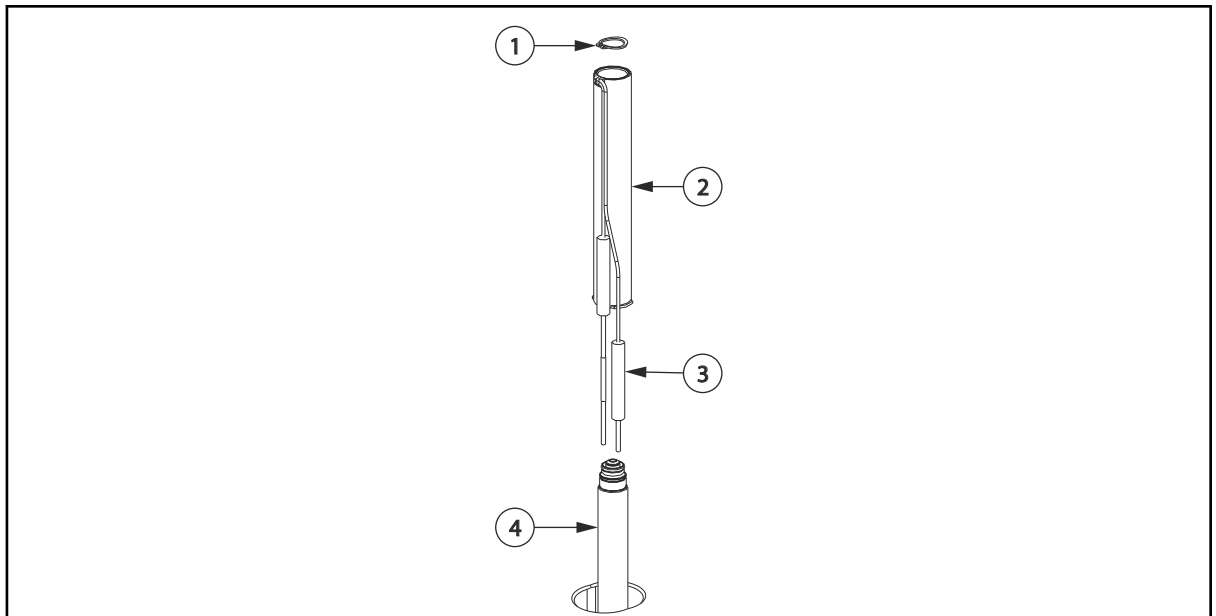

Figure 6-97: VG-HP Nozzle Heater Assembly

1. Retaining Clip 2. VG-HP Nozzle Heater 3. Thermocouple 4. Nozzle Housing and Nozzle Tip

2. Install the retaining clip on the nozzle tip and pull the nozzle heater assembly up against it.
3. Route the thermocouple wires through the wire channels in the manifold plate. Make sure all wiring is properly retained in the wire channels using wire clips.
4. Make sure to stagger the knuckles in the wire grooves.



Figure 6-98: Staggering the Knuckles in the Wire Grooves

NOTE:

All wire, including heater or thermocouple wire, that could contact a heated component such as a nozzle housing or manifold must be mineral insulated high temperature wire (hard lead). If the mineral insulated lead is not long enough to allow this, additional steps must be taken, such as using high temperature sleeving, to prevent the knuckles and PTFE or Kapton insulated wire (soft lead) from overheating.

5. Label each wire with the heater zone number. Refer to the electrical schematic for the zone number.
6. Crimp the wire ends and connect the wires to the appropriate multi-pin connectors. Refer to the electrical schematic for more information.
7. Test each nozzle heater. Refer to [Section 6.5](#) for more information.

6.18 Removing and Installing Nozzle Tip Insulators (If Equipped)

Nozzle tip insulators protect the gate details and nozzle tips from damage and prevent resin leaks.

The following procedures describe how to remove and install nozzle tip insulators.

6.18.1 Removing the Nozzle Tip Insulators

To remove the nozzle tip insulators, do the following:



WARNING!

Burn hazard – risk of serious injury. To avoid serious burns, wear personal protective equipment consisting of a heat-resistant coat, heat-resistant gloves, and a full face shield over safety glasses. Use adequate ventilation for fumes.

1. Separate the cavity plate from the hot runner. Refer to [Section 6.6](#) for more information.
-

NOTE:

Some nozzle tip insulators may remain in the gate detail in the cavity plate.

2. Lock out and tag the machine. For machine lockout and tag procedures refer to the machine documentation.
-



IMPORTANT!

Due to geometric variations between the gate details and the witness marks left in the nozzle tip insulators by the nozzle tips, Husky does not recommend reusing nozzle tip insulators. Previously used nozzle tip insulators should always be replaced with new nozzle tip insulators. If reuse is absolutely necessary (i.e. unscheduled maintenance with no spares on hand), order new nozzle tip insulators and replace as soon as possible. Contact your nearest Husky Regional Service and Sales Office or www.husky.co.



IMPORTANT!

Nozzle tip insulators form to the dimensions of the nozzle tip and gate detail when compressed. Before removing a nozzle tip, make sure to record the nozzle tip location and the orientation of the nozzle tip insulator. This will help avoid resin leakage if the nozzle tip insulators are reused.

3. If nozzle tips must be reused, record the position and orientation of each nozzle tip insulator.
-

CAUTION!

Mechanical hazard – risk of equipment damage. Do not allow molten resin to drop on nozzle tip insulators while the insulators are being removed. The additional material will increase the calculated preload for the nozzle tip insulator and damage the hot runner during assembly with the cavity plate.

Make sure all nozzle tip insulators are clean during removal and installation.

4. Remove the nozzle tip insulators from the nozzle tips using needle nose pliers. Be careful not to damage the nozzle tips, stem or sealing surfaces.
5. If a nozzle tip insulator is found in the gate detail in the cavity plate, remove the nozzle tip insulator using a 10 mm or 3/8"-18 NPT tap or pipe and then clean the gate.

Clean the gate detail using a pointed hardwood stick and soft cloth, or a Scotch-Brite No. 7447 (Maroon). Care must be taken not to scratch the cylindrical sealing surfaces between the gate insert and nozzle housing. Even a slight scratch may cause leaks at high injection pressures.

6. Inspect the nozzle tip insulators for resin. If resin is found, the nozzle tip insulator is leaking and will not function as required.

Determine the following:

- The cause of the leak by inspecting the gate insert dimensions.
- The nozzle tip position to make sure it is correct before a new insulator is installed.

7. Remove all locks and tags.

6.18.2 Installing the Nozzle Tip Insulators

To install the nozzle tip insulators, do the following:

**IMPORTANT!**

Due to geometric variations between the gate details and the witness marks left in the nozzle tip insulators by the nozzle tips, Husky does not recommend reusing nozzle tip insulators. Previously used nozzle tip insulators should always be replaced with new nozzle tip insulators. If reuse is absolutely necessary (i.e. unscheduled maintenance with no spares on hand), order new nozzle tip insulators and replace as soon as possible. Contact your nearest Husky Regional Service and Sales Office or www.husky.co.

CAUTION!

Mechanical hazard – risk of damage to the hot runner. Make sure all nozzle tip insulators are clean before they are installed. Any additional material on the nozzle tip insulator will increase the calculated preload and damage the hot runner during assembly with the cavity plate.

1. Make sure the hot runner is either installed in the machine or laying on a work bench with the nozzle tips facing up.
2. Make sure all nozzle tip insulators are clean and in good condition.

CAUTION!

Mechanical hazard – risk of damage to the hot runner. Nozzle tip insulators form to the dimensions of the nozzle tip and gate detail when compressed. Make sure previously used nozzle tips are installed on the same nozzle tip in the same orientation. Resin leakage will occur otherwise.

3. Place a nozzle tip insulator on each nozzle tip. If used nozzle tip insulators are being installed, make sure they are installed on the same nozzle tip as previously removed and in the same orientation.



4. Make sure there are no nozzle tip insulators in the gate inserts.
5. Install the cavity plate. Refer to [Section 6.6](#) for more information.

6.19 Removing Insulating Gate Bubbles (If Equipped)

In place of nozzle tip insulators, some hot runners form a bubble of resin at the nozzle tip referred to as an insulating gate bubble. The bubbles provide thermal insulation between the nozzle tip and the cold cavity plate steel. They also increase the speed of color changes and prevent the degradation of some heat sensitive resins. The gate bubble needs to be removed if the gate hole is blocked by contamination.

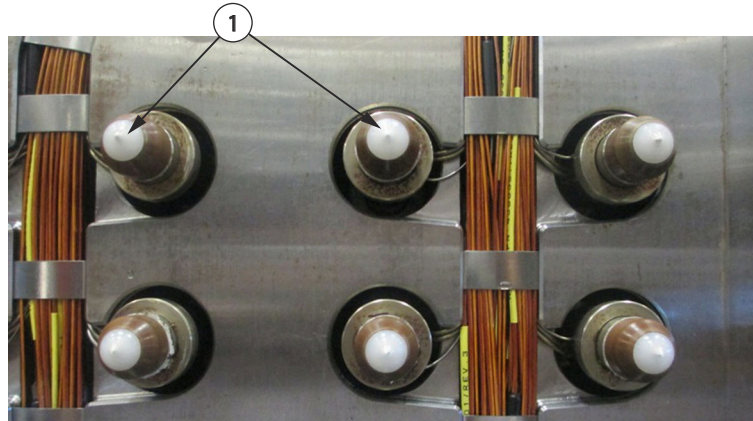

Figure 6-100: Gate Bubbles

1. Gate Bubbles

To remove the insulating gate bubbles, do the following:

1. Remove the cavity plate. Refer to [Section 6.6](#) for more information.
2. Connect the hot runner to a controller.
3. Turn on the controller.



DANGER!

Electrocution hazard – risk of serious injury and/or damage to the hot runner. Do not turn on the heaters if water has leaked into the hot runner. If water has leaked into the hot runner, the hot runner must be completely disassembled, dried and assembled before the heaters are turned on.



WARNING!

Hot resin spray hazard – risk of serious injury. Hot resin may unexpectedly spray from the nozzle tips while the hot runner is reaching operating temperature. To avoid serious burns, wear personal protective equipment consisting of a heat-resistant coat, heat-resistant gloves and a full face shield over safety glasses. Use adequate ventilation for fumes.



WARNING!

Burn hazard – risk of serious injury. Hot runner components stay hot for long periods of time after heaters have been turned off. Wear personal protective equipment when working near the hot runner and place a warning sign in the area before leaving the hot runner unattended.

4. Increase the temperature of a row of nozzle tips to a temperature high enough to soften the insulating gate bubble.

NOTE:

The Vicat Softening Temperature for the resin type is recommended. Refer to the resin supplier’s documentation for more information.

5. Once the nozzle tips have reached their setpoint approximately 120 °C (248 °F), wait until the gate bubble on the first nozzle tip is soft enough to remove and then turn off all the nozzle tip heaters.



WARNING!

Electrocution hazard - risk of death or serious injury. Complete the lockout/tagout procedure of the electrical power source before disconnecting the electrical connectors.

6. Lock out and tag the electrical power source.



IMPORTANT!

Do not allow the nozzle tips to overheat or degraded material will have to be cleaned out of the nozzle housing before a new nozzle tip can be installed.

7. Disconnect the controller.
8. Remove all gate bubbles from the row with brass pliers, a clean cloth or a soft wire brush.
9. Repeat [step 4](#) to [step 8](#) for all subsequent rows.



WARNING!

Burn, fire and gas hazard – risk of death or serious injury, and property damage. Use of an open flame to remove resin could produce harmful gases (depending on the resin type), damage components and increase the risk of fire. Only use open flames sparingly and in a controlled environment.



WARNING!

Burn hazard – risk of serious injury. To avoid serious burns, wear personal protective equipment consisting of a heat-resistant coat, heat-resistant gloves, and a full face shield over safety glasses. Use adequate ventilation for fumes.

CAUTION!

Mechanical hazard – risk of damage to the equipment. Abrasives should never be used to clean the nozzle tips, as this could damage the critical sealing surfaces.

Do not remove the gate bubble with a hammer or tools made of hard material. Use tools made of soft materials such as brass, copper or wood. Hammering or using hard material tools could result in damage to the nozzle tips.

10. Remove any insulating gate bubbles in the cavity plate. If required, carefully heat the gate bubbles with a propane torch and then wipe the deposits away with a clean, soft cloth or soft wire brush. This may have to be repeated several times.

CAUTION!

Mechanical hazard – risk of damage to the hot runner. Do not allow molten resin to drop on or build up under the nozzle tip insulators while the gate bubbles are being removed. The additional material will increase the calculated preload for the nozzle tip insulator and damage the hot runner during assembly with the cavity plate.

Make sure all nozzle tip insulators are clean and seated correctly before installing the cavity plate.

-
11. Make sure all nozzle tip insulators (if equipped) are seated correctly with a minimal and even gap between the nozzle tip insulator and the nozzle housing. For reused nozzle tips, the gap may not be noticeable. When plastic is under the nozzle tip insulator, it will have a larger than usual and/or uneven gap in relation to the nozzle housing. If plastic is under the nozzle tip insulator it must be cleaned or replaced. For more information on removing and installing the nozzle tip insulator refer to [Section 6.18](#).



Figure 6-101: Seating the Nozzle Tip Insulator (Example)

To remove, clean and install the nozzle tip insulator, do the following:

- a. Mark the orientation of the nozzle tip insulator.
- b. Remove the nozzle tip insulator.

**IMPORTANT!**

If the nozzle tip insulator is damaged or cannot be cleaned then it must be replaced.

-
- c. Clean the nozzle tip insulator by heating to melt the residual plastic and wiping it clean.
 - d. Install the nozzle tip insulator. Nozzle tip insulators must be installed on the same nozzle tip in the original orientation.
12. Make sure the hot runner is at room temperature <math><25\text{ }^\circ\text{C}</math> (<math><77\text{ }^\circ\text{F}</math>).

NOTE:

If the hot runner is still in the machine the cooling water can be turned on to cool the hot runner down.

13. Install the cavity plate. Refer to [Section 6.6](#) for more information.

6.20 Removing and Installing Manifold Bushings

The following procedures describe how to remove, maintain and install manifold bushings.

Manifold bushings need to be replaced if the following occurs:

- The valve stem is stuck and cannot be removed
 - The valve stem bore is worn and leaking heavily back into the actuation area
 - The manifold bushing is collapsed from overheating
 - The air seal face is damaged
 - The manifold bushing is damaged in a way that renders it unusable
-

NOTE:

Husky provides two styles of manifold bushings: press fit or slip fit. Press fit manifold bushings are typically used in systems designed to process heat-sensitive resins. Slip fit manifold bushings are used in systems designed to process resins that are not heat-sensitive. Refer to the assembly drawings to determine if the manifold bushings are press fit or slip fit.

6.20.1 Removing and Installing Press Fit Manifold Bushings

It is recommended that press fit bushings be removed and replaced by Husky. Contact your Husky Regional Service and Sales office for more information about removing press fit manifold bushings.

6.20.2 Removing Slip Fit Manifold Bushings

To remove slip fit manifold bushings, do the following:

1. Disconnect the manifold and thermocouple wires from the manifolds.
2. Remove the nozzle heaters and thermocouples. Refer to [Section 6.17](#) for more information.
3. Remove the nozzle tips. Refer to [Section 6.14](#) for more information.
4. Remove the nozzle housings. Refer to [Section 6.16](#) for more information.
5. Remove the manifold from the manifold plate pocket. Refer to [Section 6.9.2](#) for more information.
6. Press the manifold bushings out of the manifold using a heavy brass punch. Take care not to damage the bushings or manifold.

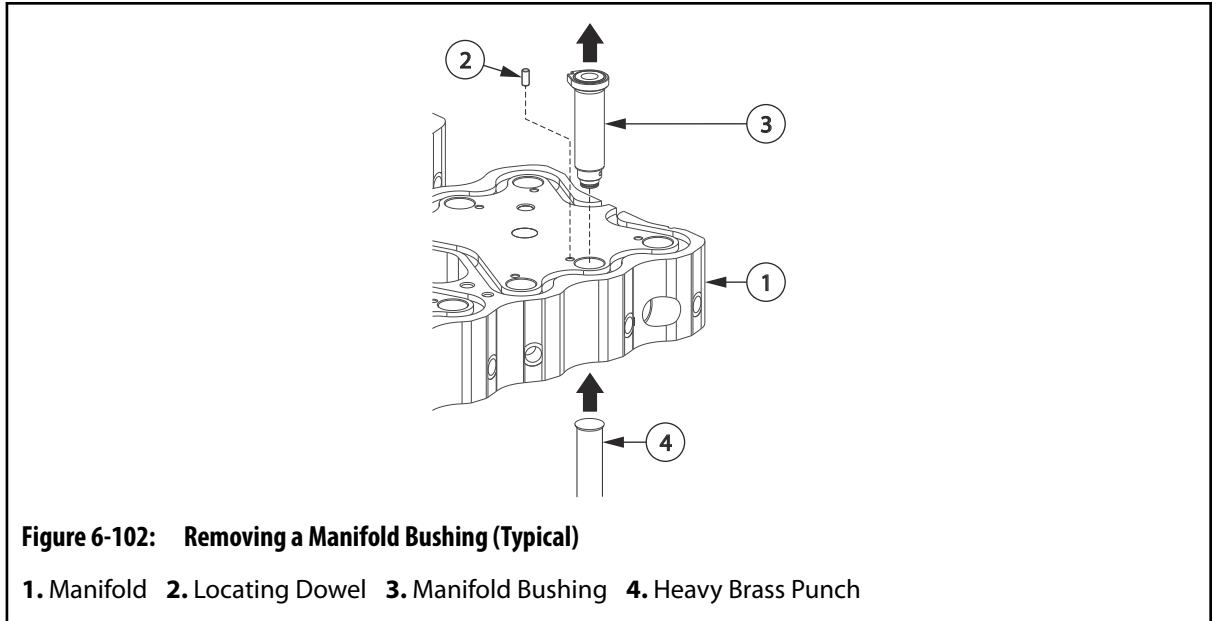

6.20.3 Installing Slip Fit Manifold Bushings

To install slip fit manifold bushings, do the following:

1. Remove any resin from the manifold bushing pockets and seating area in the manifold plate using brass scrapers. Do not damage the sharp corners or sealing surfaces.
2. Remove any resin from the exterior of the manifold bushings with brass scrapers. Do not damage the sharp corners or sealing surfaces.
3. Make sure the interior of the manifold bushing is free of resin.
4. Clean the stem bore in the manifold bushing with alcohol and cotton swabs. The interior is clean when a cotton swab can be removed from the bushing without any dirt on it.
5. Use a medium India stone (240 grit oil stone) to clean all mating surfaces on the manifold. Do not scratch the manifold.
6. Check that all contact surfaces on the manifold plate, center plate or air plate and manifold bushings are clean and free of residue, scratches, nicks, or burrs.
7. Make sure the manifold bushing locating dowel is installed in the manifold.

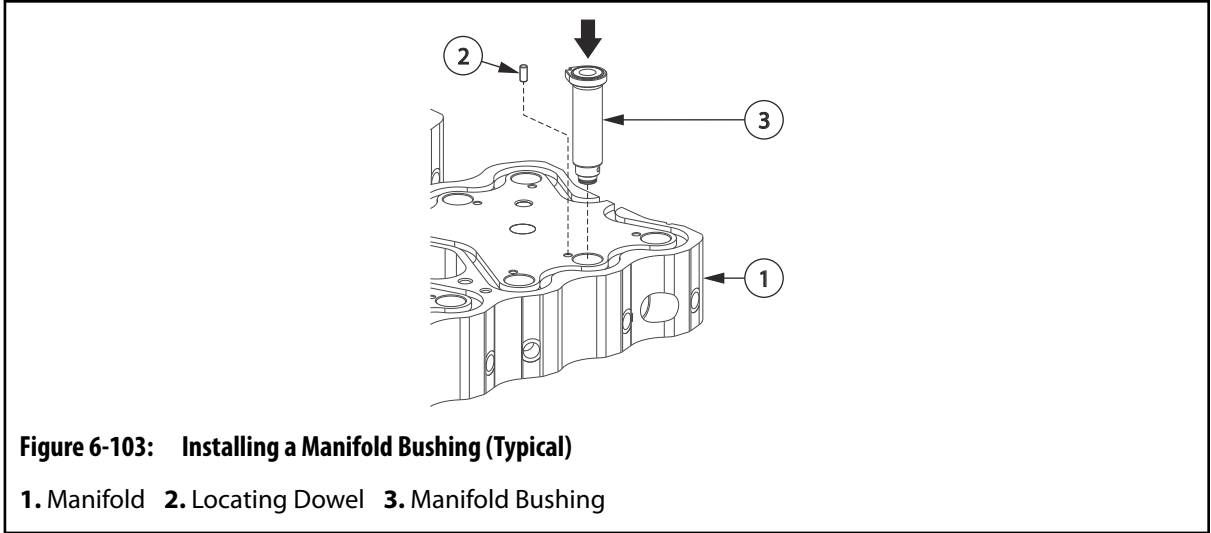

8. Align the manifold bushing with the locating dowel and press the bushing into the manifold until the bushing bottoms out on the manifold. Repeat this step for all manifold bushings.

6.21 Removing and Installing the Sprue Heater (If Equipped)

The following procedures describe how to remove and install a sprue heater with a built-in thermocouple or a separate thermocouple.

6.21.1 Removing a Sprue Heater with a Built-In Thermocouple

To remove a sprue heater that has a built-in thermocouple, do the following:

1. If necessary, remove the hot runner from the machine. Refer to [Section 4.3](#) for more information.
2. If a center plate is not equipped, remove the backing plate. Refer to [Section 6.7](#) for more information.
3. Disconnect the sprue heater and thermocouple wires from the multi-pin connectors.

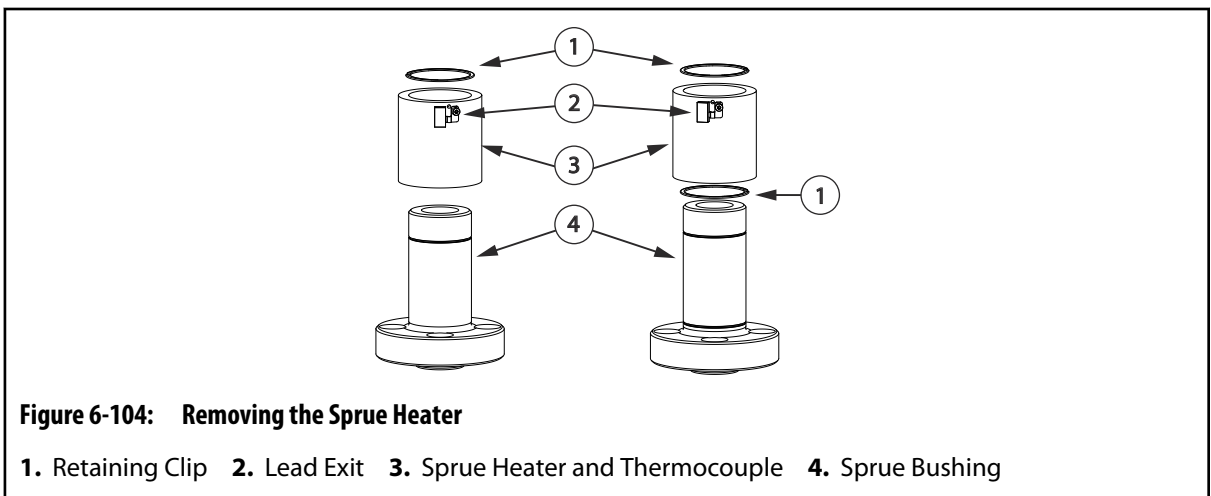

4. Remove the sprue heater and thermocouple wires from the wire channels in the manifold plate.
5. Remove the retaining clip from the sprue bushing.
6. Remove the sprue heater and thermocouple from the sprue bushing.

6.21.2 Removing a Sprue Heater with a Separate Thermocouple

To remove a sprue heater that has a separate thermocouple, do the following:

1. If necessary, remove the hot runner from the machine. Refer to [Section 4.3](#) for more information.
2. If a center plate is not equipped, remove the backing plate. Refer to [Section 6.7](#) for more information.
3. Disconnect the sprue heater and thermocouple wires from the multi-pin connectors.

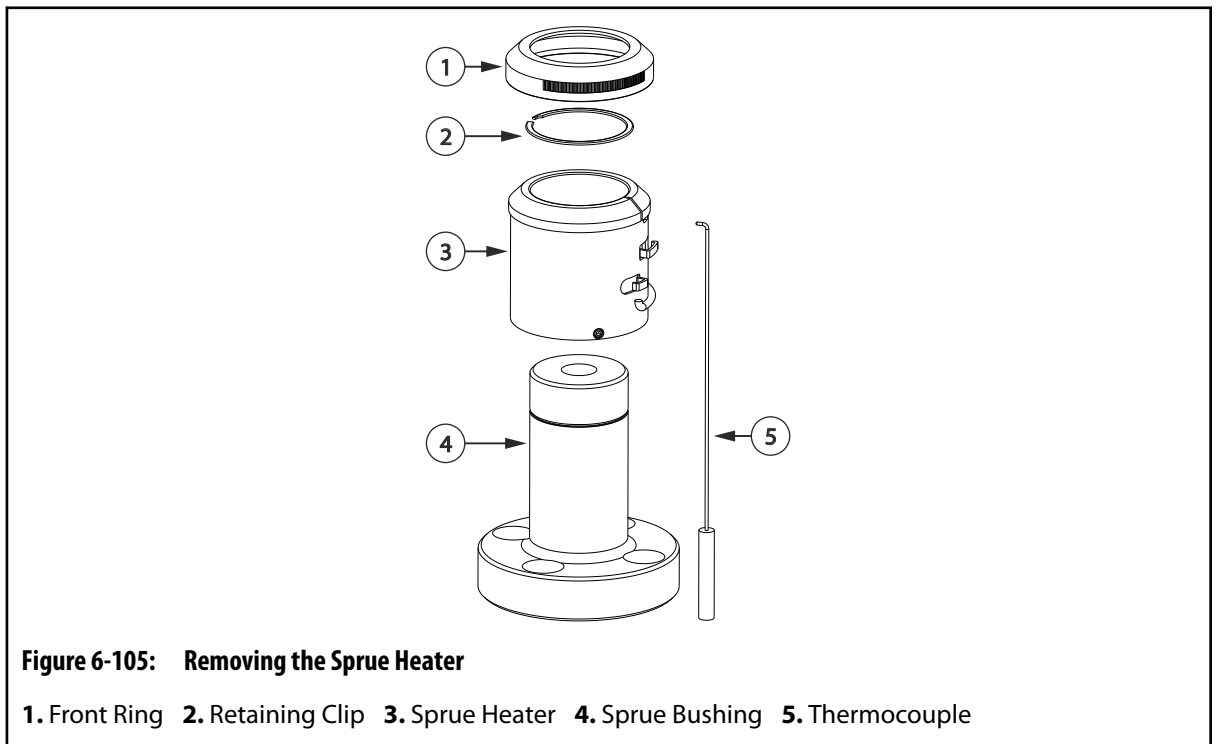

4. Remove the sprue heater and thermocouple wires from the wire channels in the manifold plate.
5. Remove the front ring, retaining clip and thermocouple.
6. Using a heater removal tool, remove the sprue heater from the sprue bushing. Refer to [Section 1.8](#) for a list of special Husky tools and order numbers.

6.21.3 Installing a Sprue Heater with a Built-In Thermocouple

To install a sprue heater with a built-in thermocouple, do the following:

1. If there are two retaining clip grooves, install a retaining clip in the groove closest to the manifold.

2. With the lead exit facing away from the manifold, slide the sprue heater onto the sprue bushing. Make sure the sprue heater is below the retaining clip groove in the sprue bushing.

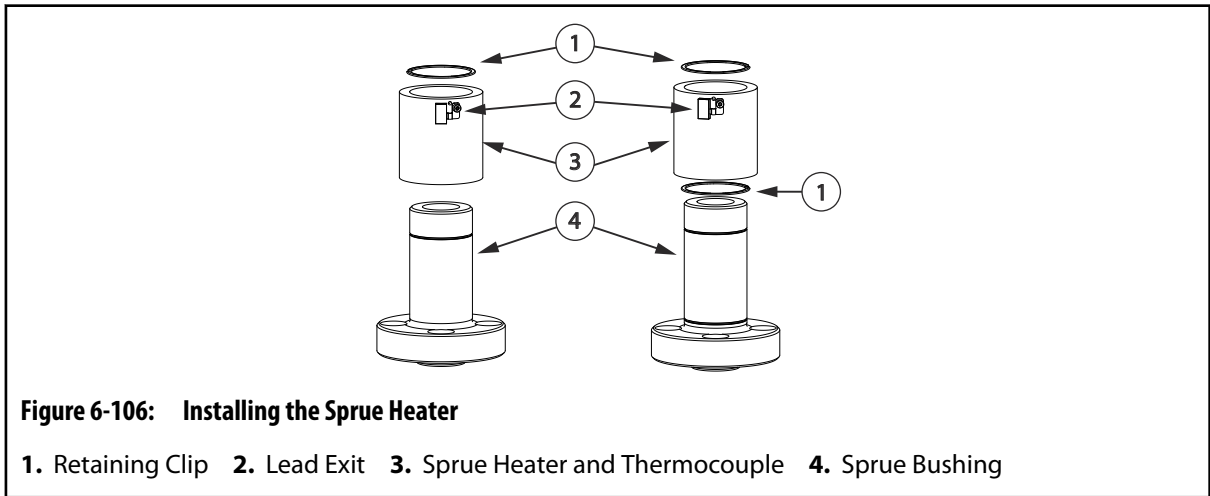

3. Align the heater and thermocouple wires with the wire channels in the backing plate.
4. Install the retaining clip into the groove on the sprue bushing.
5. Pull the sprue heater up until it makes contact with the retaining clip.

NOTE:

All wiring near the sprue heater must be either a high temperature braid or sleeved using a high temperature sleeving.

6. Route the sprue heater and thermocouple wires through the wire channels in the manifold plate. Make sure all wiring is properly retained in the wire channels using wire clips.
If the wire length is too long or too short, refer to [Section 6.24](#) for information about adjusting the wire length.
7. Label each wire with the heater zone number. Refer to the electrical schematic for the zone number.
8. Crimp the wire ends and connect them to the appropriate multi-pin connectors. Refer to the electrical schematic for more information.
9. Test the sprue heater. Refer to [Section 6.5](#) for more information.
10. If a center plate is not equipped, install the backing plate. Refer to [Section 6.7.2](#) for more information.

6.21.4 Installing a Sprue Heater with a Separate Thermocouple

To install a sprue heater with a separate thermocouple, do the following:

1. Slide the sprue heater onto the sprue bushing. Make sure the sprue heater is below the retaining clip groove in the sprue bushing.

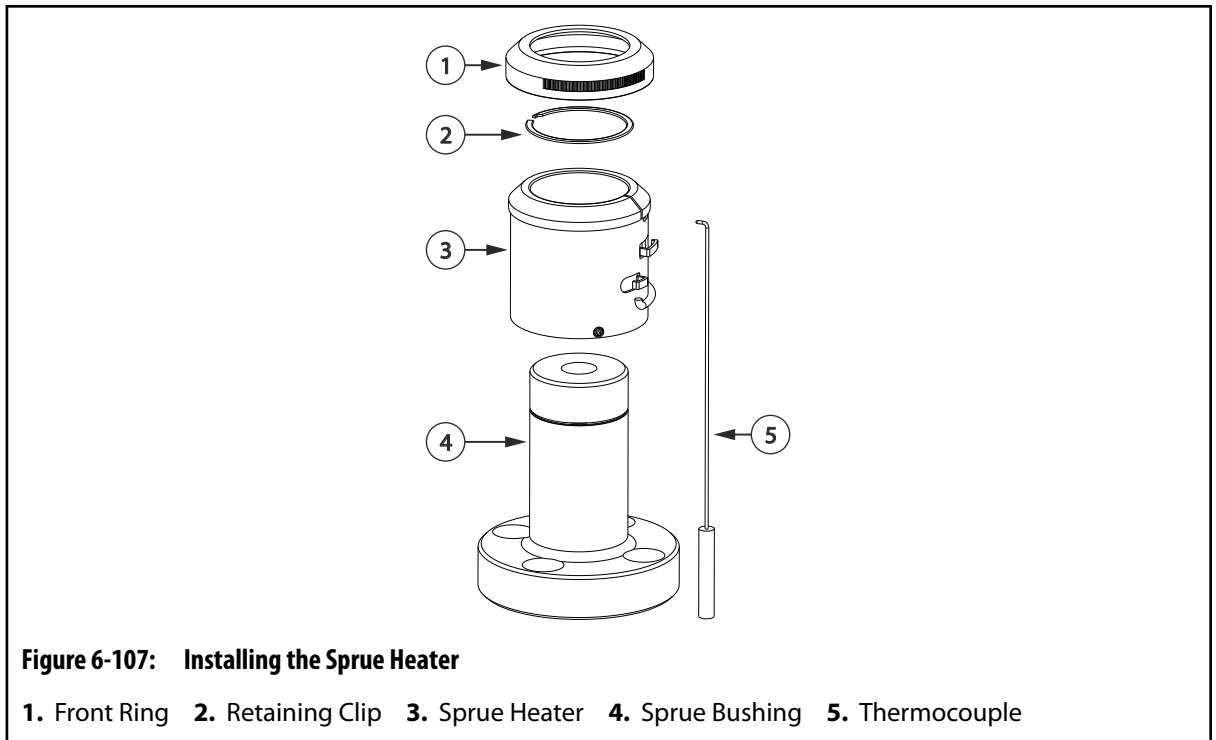

2. Install the retaining clip into the groove on the sprue bushing.
3. Using a heater removal tool, pull the sprue heater up until it makes contact with the retaining clip. Refer to [Section 1.8](#) for a list of special Husky tools and order numbers.

NOTE:

All wiring near the sprue heater must be either a high temperature braid or sleeved using a high temperature sleeving.

4. Connect the thermocouple to the sprue heater.
5. Route the sprue heater and thermocouple wires through the wire channels in the manifold plate. Make sure all wiring is properly retained in the wire channels using wire clips.
If the wire length is too long or too short, refer to [Section 6.24](#) for information about adjusting the wire length.
6. Thread the front ring onto the sprue heater and tighten by hand.
7. Label each wire with the heater zone number. Refer to the electrical schematic for the zone number.
8. Crimp the wire ends and connect them to the appropriate multi-pin connectors. Refer to the electrical schematic for more information.
9. Test the sprue heater. Refer to [Section 6.5](#) for more information.
10. If a center plate is not equipped, install the backing plate. Refer to [Section 6.7.2](#) for more information.

6.22 Removing and Installing the Sprue Bushing

The following procedures describe how to remove, maintain and install the sprue bushing.

6.22.1 Removing the Sprue Bushing

To remove the sprue bushing, do the following:

1. Remove the hot runner from the machine. Refer to [Section 4.3](#) for more information.
2. Remove the backing plate. Refer to [Section 6.7](#) for more information.
3. If equipped, remove the center plate. Refer to [Section 6.8.1](#) for more information.
4. Remove the sprue heater. Refer to [Section 6.21](#) for more information.
5. Remove the screws that secure the sprue bushing to the manifold.

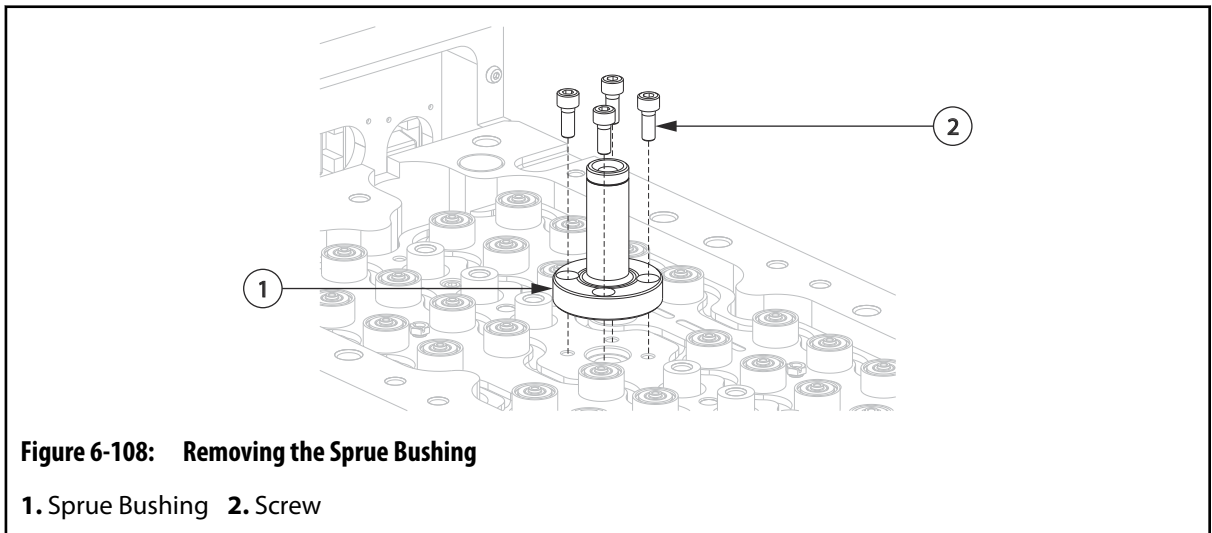

6. Remove the sprue bushing.
7. Using a brass rod, remove the resin slug from the sprue bushing melt channel.
8. Clean the sprue bushing. Do not damage any sealing surfaces.
9. Check and repair the nozzle radius, if required.

6.22.2 Installing the Sprue Bushing

To install the sprue bushing, do the following:



WARNING!

Hot resin spray hazard – risk of serious injury. Any contamination or damage at the sprue bushing and manifold interface could cause hot resin to spray out of the mold, possibly resulting in serious burns. Both the mounting faces of the sprue bushing and manifold must be spotlessly clean and undamaged. The mounting screws must also be torqued to the specified value.

NOTE:

The supplied screws used to install the sprue bushing are of a special quality and must not be substituted.

1. Clean the surfaces on the sprue bushing and manifold where the two components will interface.

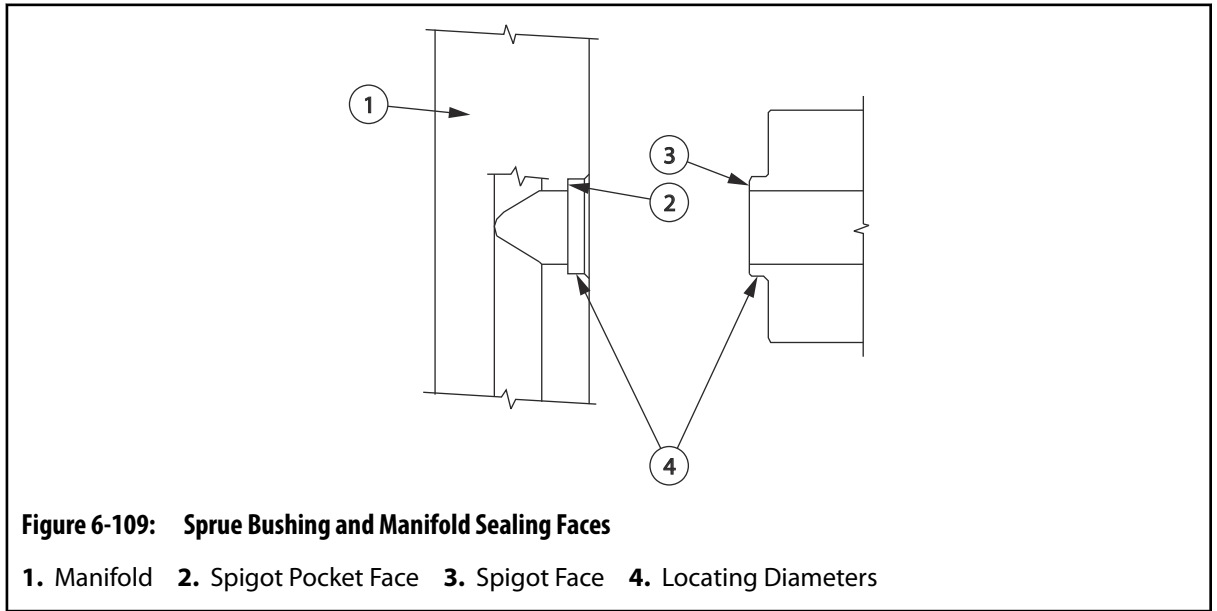
**CAUTION!**

Crushing hazard – risk of damage to equipment. Screws used to install sprue bushings must meet specific requirements. Only use the screws specified in the assembly drawings. Failure to use these screws may result in equipment damage.

2. Apply a high temperature anti-seize lubricant to the screws used to install the sprue bushing. Refer to [Section 3.5](#) for information about recommended lubricants.

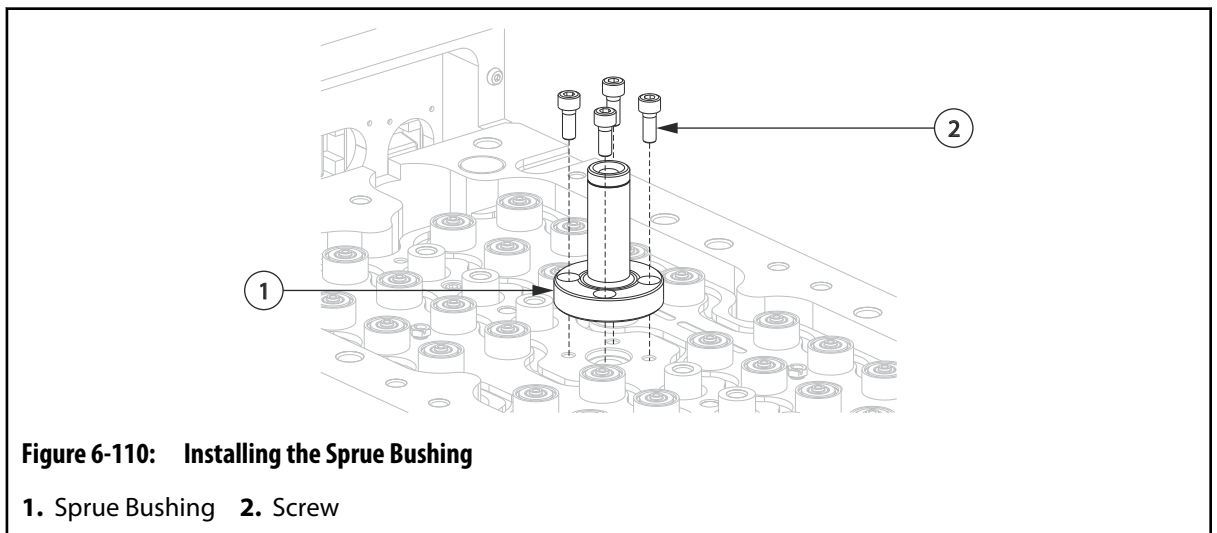

3. Install the sprue bushing and torque all screws to half the specified value in a cross pattern. Refer to the assembly drawings for torque requirements.
4. Torque the screws fully to the specified value to make sure an even seal is made between the sprue bushing and manifold. Refer to the assembly drawings for torque requirements.
5. Install the sprue heater. Refer to [Section 6.21](#) for more information.
6. If equipped, install the center plate. Refer to [Section 6.8.2](#) for more information.
7. Install the backing plate. Refer to [Section 6.7.2](#) for more information.
8. Install the hot runner into the machine. Refer to [Section 4.3.1](#) for more information.

6.23 Removing and Installing Transfer Bushings (If Equipped)

The following procedures describe how to remove and install transfer bushings.

6.23.1 Removing Transfer Bushings (If Equipped)

To remove a transfer bushing, do the following:

1. Remove the transfer bushing cover plates.

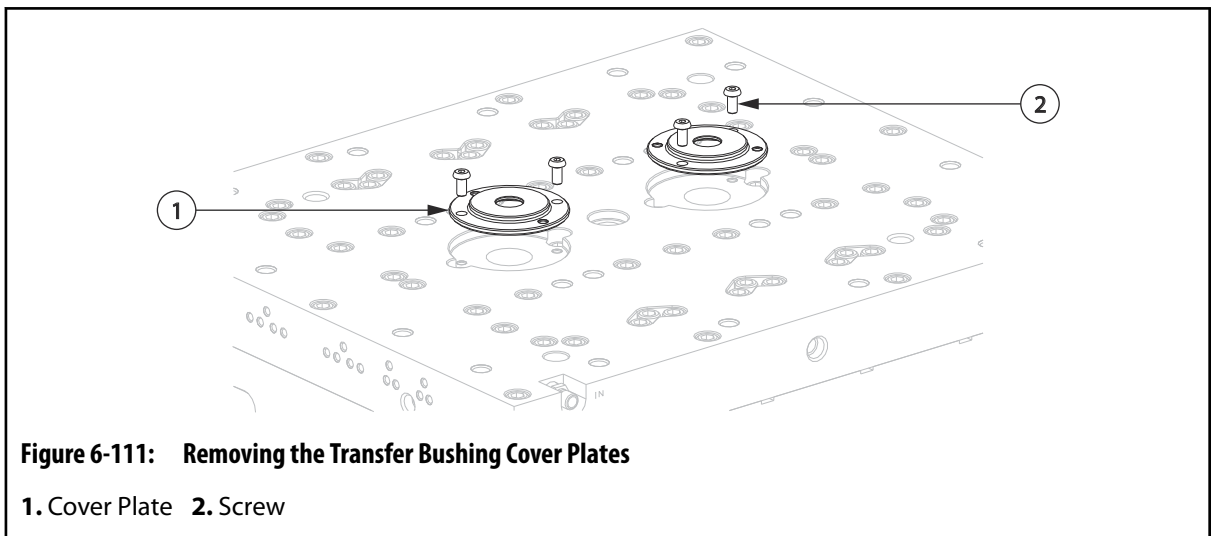

2. Remove the center plate. Refer to [Section 6.8.1](#) for more information.
3. Disconnect the transfer bushing heater and thermocouple wires from the multi-pin connectors.

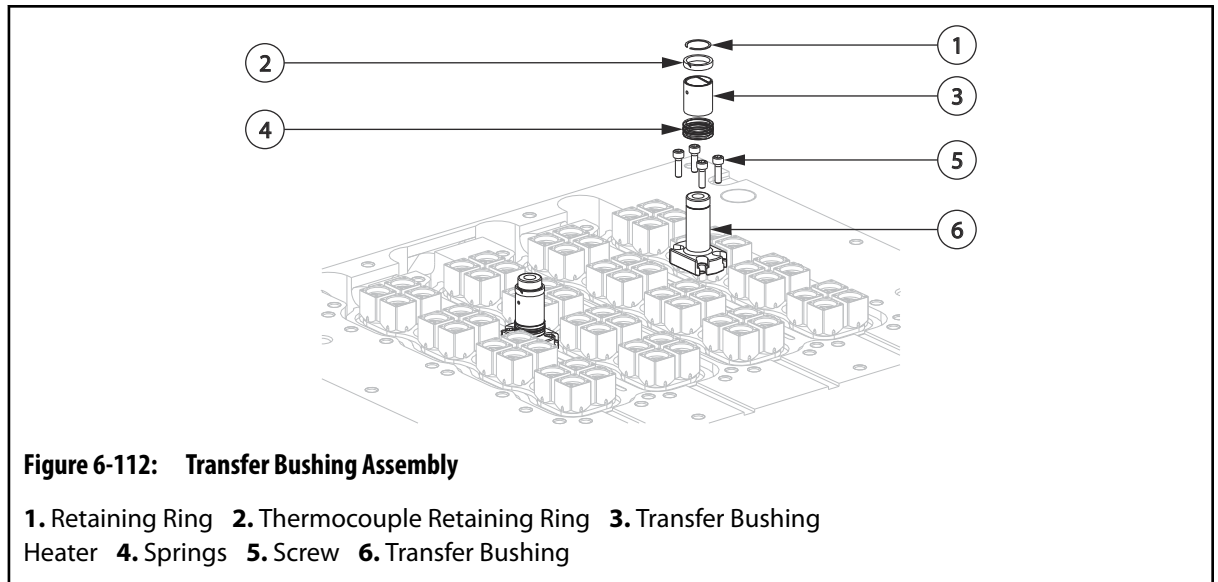

4. Remove the transfer bushing heater and thermocouple wires from the wire channels in the manifold plate.
5. Remove the retaining clip from the transfer bushing.
6. Remove the thermocouple retaining ring from the heater.
7. Remove the heater and springs.
8. Inspect the springs for wear, corrosion, cracks or other damage. Replace the springs if necessary.
9. Remove the screws that secure the transfer bushing to the manifold.
10. Remove the transfer bushing.
11. Using a brass rod, remove the resin slug from the transfer bushing melt channel.
12. Clean the transfer bushing. Do not damage any sealing surfaces.

6.23.2 Installing Transfer Bushings (If Equipped)

To install a transfer bushing, do the following:

NOTE:

The supplied screws used to install the transfer bushing are of a special quality and must not be substituted.

1. Clean the surfaces on the transfer bushing and manifold where the two components will interface.

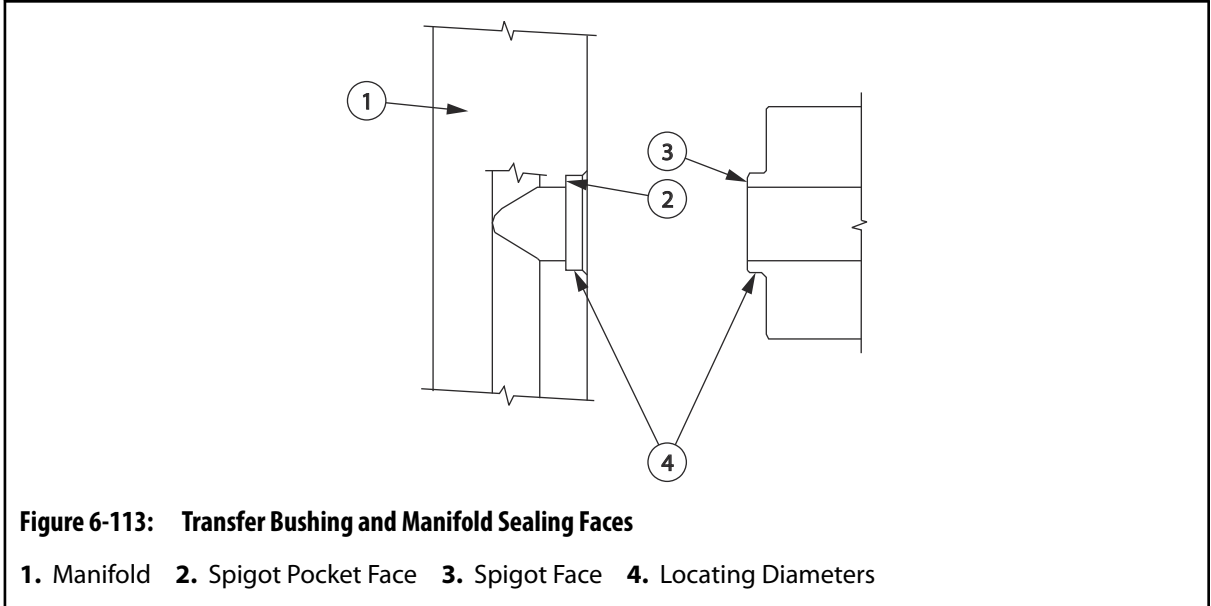

CAUTION!

Crushing hazard – risk of damage to equipment. Screws used to install transfer bushings must meet specific requirements. Only use the screws specified in the assembly drawings. Failure to use these screws may result in equipment damage.

2. Apply a high temperature anti-seize lubricant to the screws used to install the transfer bushing. Refer to [Section 3.5](#) for information about recommended lubricants.

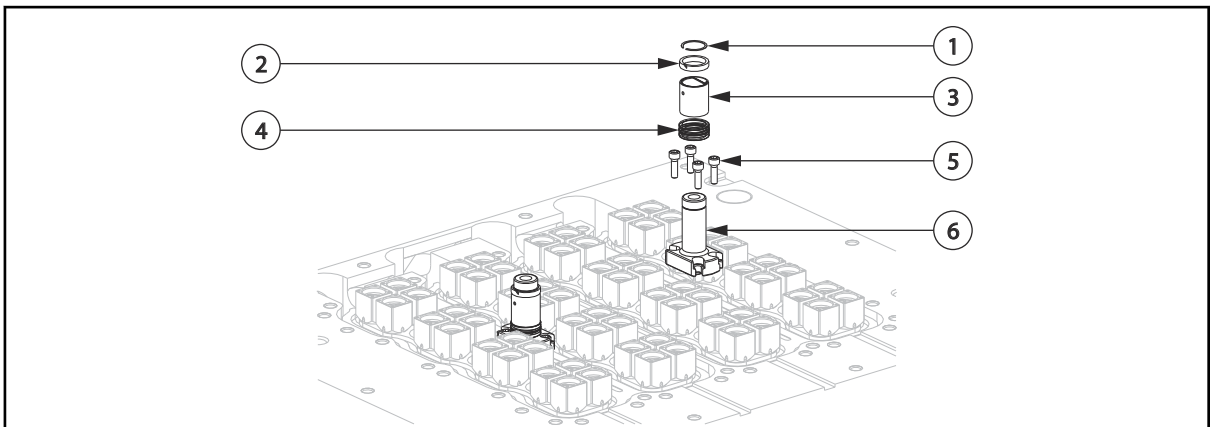

Figure 6-114: Transfer Bushing Assembly

1. Retaining Ring 2. Thermocouple Retaining Ring 3. Transfer Bushing Heater 4. Springs 5. Screw 6. Transfer Bushing

3. Install the transfer bushing and torque all screws to half the specified value in a cross pattern. Refer to the assembly drawings for torque requirements.
4. Torque the screws fully to the specified value to make sure an even seal is made between the transfer bushing and manifold. Refer to the assembly drawings for torque requirements.
5. Slide springs onto the transfer bushing.

6. Slide the transfer bushing heater onto the transfer bushing. Make sure the transfer bushing heater is below the retaining clip groove in the transfer bushing.
7. Snap the thermocouple ring onto the transfer bushing heater.
8. Install the retaining clip into the groove on the transfer bushing.

NOTE:

All wiring near the transfer bushing heater must be either a high temperature braid or sleeved using a high temperature sleeving.

9. Route the transfer bushing heater and thermocouple wires through the wire channels in the manifold plate. Make sure all wiring is properly retained in the wire channels using wire clips.
If the wire length is too long or too short, refer to [Section 6.24](#) for information about adjusting the wire length.
10. Label each wire with the heater zone number. Refer to the electrical schematic for the zone number.
11. Crimp the wire ends and connect them to the appropriate multi-pin connectors. Refer to the electrical schematic for more information.
12. Test the transfer bushing heater. Refer to [Section 6.5](#) for more information.
13. Install the center plate. Refer to [Section 6.8.2](#) for more information.
14. Install the transfer bushing cover plates.

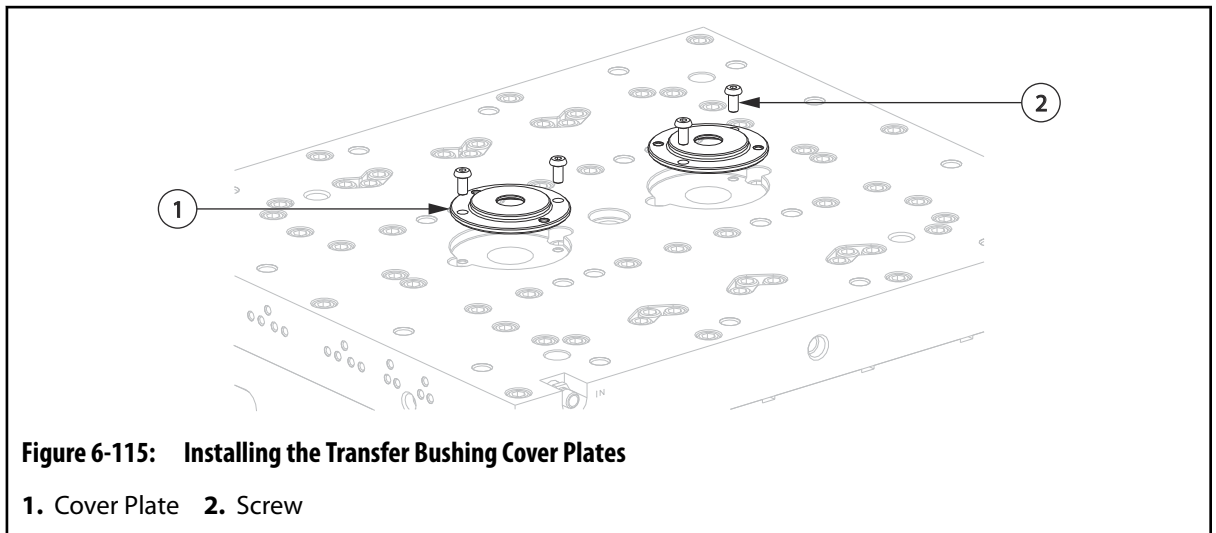

15. Install the backing plate. Refer to [Section 6.7.2](#) for more information.

6.24 Adjusting the Thermocouple Wire Length

In some cases, the length of a thermocouple wire may be too long or too short depending on the size of the hot runner. The following are recommendations for adjusting the wire length:

1. **Long Thermocouple Wires**

For small hot runners where the lead length is greater than required, wrap the wires around the heater body to reduce slack and make sure the wires fit properly in the wire channel.

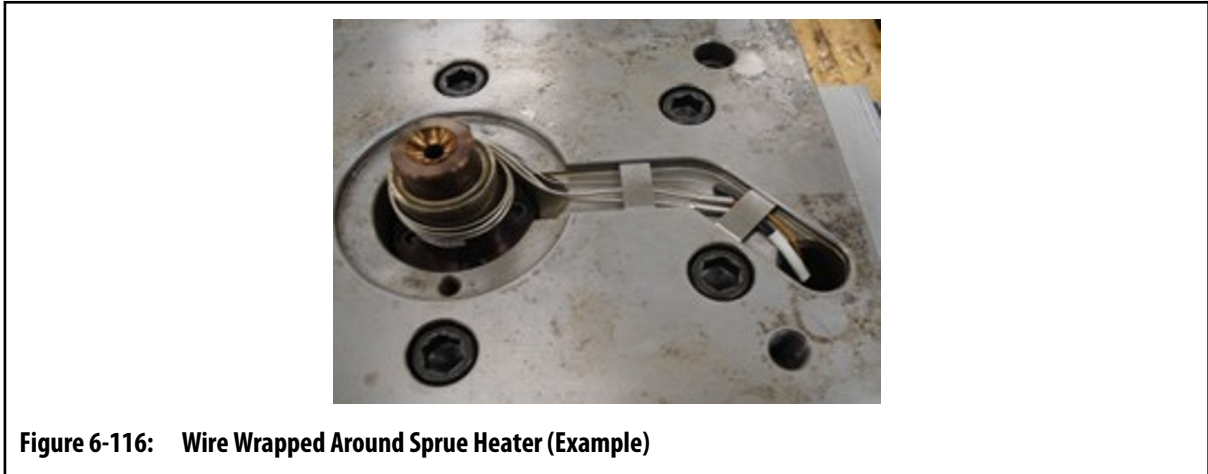

2. Short Thermocouple Wires

For large hot runners where the lead length is insufficient to reach a wire channel, cut and install a length of fiberglass sleeving to protect the wire.

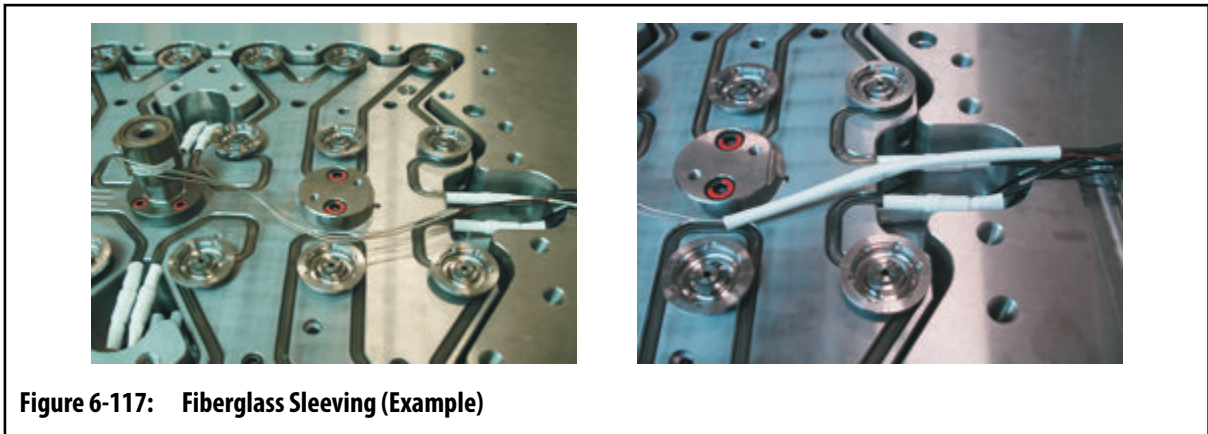

6.25 Removing Air and Water Plugs



IMPORTANT!

Husky does not recommend the removal of seized air and water plugs in the field. Contact Husky to arrange returning the hot runner for repair and/or rework. This procedure was prepared by Husky at the request of the customer, and does not in any way absolve the customer from fulfilling their usual obligations, including those mentioned above. Husky disclaims liability for damage to property or injury to personnel caused by the customer attempting the procedure. It is the obligation of the customer to confirm that personnel are trained and have appropriate qualifications including: understanding the safe methods and using the correct personal protective equipment prior to performing this procedure.

**WARNING!**

Burn and mechanical hazard - risk of serious injury and/or damage to the equipment. Only qualified personnel should perform this procedure using the appropriate personal protective equipment.

**WARNING!**

Burn hazard – risk of serious injury. To avoid serious burns, do not touch the plate or plug after heating and wear personal protective equipment consisting of a heat-resistant coat, heat-resistant gloves, and a full face shield over safety glasses.

1. Heat the plate area surrounding the stainless steel plug with a hand held torch for 1-2 minutes. Do not heat the plug directly.

**IMPORTANT!**

Do not use an impact gun or impact driver as the plug will seize.

2. Once the plate is heated, use a safety-rated breaker bar and the appropriate Hex socket adapter to apply pressure and back the plug out.
If the plug does not move, repeat [step 1](#) and [step 2](#).
3. If the plug cannot be removed manually using [step 1](#) and [step 2](#), the use of a magnetic drill or milling out the plug will be required.
If you are unable to safely remove the plug as described in this procedure, return the part to Husky for rework and/or repair. Contact Husky for more information.

**IMPORTANT!**

Do not use an impact gun or impact driver as the plug will seize.

4. Clean the threads on the plug and then, if required, apply the appropriate plug sealant to the threads.
5. Install the new plug. Refer to [Table 6-1](#) for the recommended torque. Contact Husky for appropriate part number

Table 6-1: Pipe Threads, Taps and Torques

Pipe Thread †STAINLESS STEEL	Tap Drill	Torque
1 - 11 1/2	29.36 mm (1.156 in)	108 N·m (80 lbf·ft)
1 1/4 - 11 1/2	38.10 mm (1.50 in)	136 N·m (100 lbf·ft)
1 1/2 - 11 1/2	44.05 mm (1.734 in)	163 N·m (120 lbf·ft)

Table 6-1: Pipe Threads, Taps and Torques (Continued)

Pipe Thread †STAINLESS STEEL	Tap Drill	Torque
2 - 11 ½	56.36 mm (6.35 in)	203 N·m (150 lbf·ft)
1/16 - 27	6.35 mm (0.250 in)	11 N·m (8 lbf·ft)
1/8 - 27	8.73 mm (0.344 in)	14 N·m (10 lbf·ft)
3/8 - 18	14.29 mm (0.563 in)	27 N·m (20 lbf·ft)
1/2 - 14	18.25 mm (0.718 in)	34 N·m (25 lbf·ft)
3/4 - 14	23.42 mm (0.922 in)	47 N·m (35 lbf·ft)

6. If you are unable to safely complete the steps in this procedure, return the part to Husky for rework and/or repair. Contact Husky for more information.

6.26 Removing Resin from the Hot Runner

Occasionally, resin may be left in the hot runner or a leakage of resin may occur due to a component failure. The resin will have to be removed at this point. However, removing the resin without damaging components requires careful attention.

The following procedures describe how to carefully remove resin from the hot runner and hot runner components.

6.26.1 Plate Cleaning and Inspection

The following procedure describes a general cleaning and inspection process for plates. After this procedure has been completed, the application of a fluidized bed process heat is recommended.

NOTE:

The recommended procedure for removing resin from hot runner components is a controlled fluidized bed process heat. Refer to [Section 6.26.2](#) for more information.

To inspect and clean plates, do the following:



IMPORTANT!

The use of an open flame to remove resin is not recommended due to the possible gases given off by some resins and the risk of burns while working around hot resin. In addition, there exists a potential for fire when using a torch to heat and melt resin. The heat from the torch may also overheat and damage small components.

1. Using brass or hardwood scrapers, remove all resin deposits from the plates
2. Remove all cooling fittings and plugs.
3. Clean the deposits from the cooling hoses.

CAUTION!

Mechanical hazard – risk of equipment damage. Cleaning products such as scour pads and brushes can be abrasive. When using pads or brushes, do not damage surfaces. To avoid damaging surfaces, use non-abrasive products.

4. Clean the entire plate using a medium India stone (240 grit oilstone) on flat surfaces and Scotch-Brite™ No. 7447 (Maroon) on difficult to reach areas
5. Remove any deposits from the alignment bushings and alignment dowels.
6. Check the plate for the following:
 - Wear at the alignment bushings and alignment dowels
 - Corrosion in the cooling channels
 - Cracks (especially around the mold mounting bolt holes or clamp mounting slots)
 - Damage to the dowel holes
 - Sharp edges around the wire grooves

**WARNING!**

Respiratory hazard – risk of serious injury. Use an appropriate breathing apparatus as protection while using a brass wire bush or wheel. See the material safety data sheet (MSDS) from the resin supplier. As a minimum, a particle mask is recommended.

7. Rework or replace the plates as required.

NOTE:

Before re-installing components, the plate pocket(s) must be thoroughly cleaned. An electric hand drill with a brass wire wheel or a brass chisel may be used. This will prevent unnecessary scratching.

8. Install the fittings with new pipe plugs.
9. Pressure test the cooling circuits to verify there are no coolant leaks.

**WARNING!**

Wear appropriate eye and face protection following the recommendations of the ABMA (American Brush Manufacturers Association) and ANSI (American National Standards Institute) following ANSI Z87.1 “Occupational Eye and Face Protection” ANSI B165.1 and ANSI B165.2 “Safety Requirements - Power Brushes”.

**WARNING!**

Respiratory hazard – risk of serious injury. Use an appropriate breathing apparatus as protection while using a brass wire bush or wheel. See the material safety data sheet (MSDS) from the resin supplier. As a minimum, a particle mask is recommended.

10. Brush the plate surfaces with a brass wire brush and collect any dust with a vacuum.

CAUTION!

Mechanical hazard – risk of equipment damage. Cleaning products such as scour pads and brushes can be abrasive. When using pads or brushes, do not damage, scratch, or score any sealing surfaces. To avoid damaging sealing surfaces, use non-abrasive products.

11. Clean the plate with Scotch-Brite No. 7447 (Maroon).

NOTE:

Resin on plates may also be removed using the fluidized bed cleaning process, provided that all brass and copper components are removed from the plate and the plate assembly is disassembled completely. Refer to [Section 6.26.2](#) for more information.

6.26.2 Cleaning Using a Fluidized Bed Process

The following sections describe fluidized bed cleaning and how to prepare the hot runner.

Cleaning the manifold passages is rarely required. However, if necessary, manifold passages must be cleaned using the fluidized bed process. Only the fluidized bed cleaning process will successfully remove the resin completely from the melt channels of the hot runner components.

Fluidized bed cleaning is a process with aluminum oxide particles in a high temperature retort. The heated air at 343 to 454 °C (650 to 850 °F) levitates the aluminum oxide particles creating a liquid-like behavior. The temperature and flow of the fluidized bed pyrolyzes (thermally decomposes) the polymer.

NOTE:

Husky does not recommend using a fluidized bed to clean mold plates and components.

6.26.2.1 Assistance

Husky provides a full system repair and cleaning service, in addition to helping customers find a local fluidized bed cleaning process.

Contact your nearest Husky Regional Service and Sales office for more information.

6.26.2.2 Disassembling the Hot Runner for Fluidized Bed Cleaning

When disassembling a hot runner for fluidized bed cleaning, do the following:

**IMPORTANT!**

Before disassembling a hot runner for fluidized bed cleaning, please note the following:

- When removing resin from the mold, make sure the faces of the manifold are kept scratch free. Scratches around the nozzle housing, valve bushing, manifold bushing and piston cylinder, or sprue bushing/sprue bar surfaces may cause severe resin leakage.
- The thickness of the manifold(s) is extremely important for the performance of the hot runner. There is a risk that cleaning the surface through grinding or sanding would change the total height of the stack and thereby increase the cold clearance. This would result in a resin leak.

**IMPORTANT!**

The fluidized bed cleaning process will anneal Beryllium Copper (BeCu), causing rapid failure of the components when returned to service.

Mechanical cleaning of BeCu components must not damage any of the sealing surfaces. Use only soft brass, hardwood sticks, Scotch-Brite, or soft brass brushes. Do not use abrasive methods to clean BeCu components.

**WARNING!**

Poison hazard - risk of death or serious injury. Do not use abrasives in an open air environment to clean BeCu components. Airborne beryllium particles are known carcinogens. Only rework BeCu components using abrasives under flood coolants to prevent airborne particles.

**IMPORTANT!**

The Husky Warranty does not cover BeCu components used outside the operating temperature range, or cleaned using the fluidized bed process.

CAUTION!

Do not remove any surface or melt channel plugs. This will void the leak proof guarantee for the hot runner. Plugs can only be removed by Husky.

1. Any system that is to be sent for fluidized bed cleaning is to be completely disassembled. However do not send the following items for cleaning:
 - Set screws
 - Polyetheretherketone (PEEK) bushings (refer to) or ceramic bushings
 - Surface hex head plugs
 - Nozzle tip insulators

- Nozzle heaters
- Sprue bushing heaters
- Beryllium Copper (BeCu) components, such as manifold bushings, manifold inserts, some nozzle tips and tip retainers, etc.

NOTE:

Contact Husky for verification of the component’s material before cleaning it with a fluidized bed process.

2. Make sure all electrical wiring and thermocouples are removed.
3. When packing for shipment, make sure the manifold heater ends do not get damaged during shipping.

The best method is to pack the manifold in a crate where it cannot move, or place the manifold between two pieces of plywood cut approximately 50 mm (2 in) larger all around. Hold the manifold and plywood pieces together with bolts using existing hold down holes or clearance holes in the manifold. Only use plywood thick enough to protect the manifold and absorb impacts if the manifold is dropped.

4. Send a complete packing list of all the components shipped to make sure nothing is overlooked when the components are returned.

6.26.2.3 Removing the PEEK Bushings

Due to the extreme temperatures in a fluidized bed (454 °C or 850 °F), Polyetheretherketone (PEEK) bushings must be removed from the manifold heater ends. The PEEK bushings will melt if subjected to the cleaning process.

To remove the PEEK bushings, twist the bushings 1/4 turn to break the adhesive used to attach it.



Figure 6-118: PEEK Bushing Removal and Installation

The bushings must be installed after the fluidized bed cleaning process. New adhesive is not necessary.

6.27 Removing Resin from the Manifold Plate

Excess resin can weep out of the valve stem area into the manifold plate during production. This can inhibit valve stem performance, create manifold thermal control issues, and damage electrical wiring.

CAUTION!

Mechanical hazard – risk of damage to the hot runner. Weepage must be cleaned before it completely fills the back side of the manifold pocket or covers any electrical wiring.



IMPORTANT!

Do not extend the cleaning interval beyond the interval recommended in the maintenance schedule. If the rate of weepage increases significantly, valve stem and manifold bushings should be inspected for wear and replaced, if needed.

The manifold plate should be cleaned at the interval specified in the maintenance schedule. However, based on observations made during an inspection, an earlier interval may be required.

To remove resin from the manifold plate, do the following:

1. Remove the hot runner from the machine. Refer to [Section 4.3.2](#) for more information.
2. Remove the backing plate. Refer to [Section 6.7](#) for more information.
3. If equipped, remove the center plate. Refer to [Section 6.8.1](#) for more information.
4. Remove the valve stem assemblies. Refer to [Section 6.12](#) for more information.
5. Remove the backup pads or cylinders from the manifold. Refer to [Section 6.10](#) for information about removing backup pads or [Section 6.11](#) for information about removing cylinders.



WARNING!

Burn, fire and gas hazard – risk of death or serious injury, and property damage. Use of an open flame to remove resin can produce harmful gases (depending on the resin type), damage components and increase the risk of fire. Only use open flames sparingly and in a controlled environment.



WARNING!

Burn hazard – risk of serious injury. To avoid serious burns, wear personal protective equipment consisting of a heat-resistant coat, heat-resistant gloves, and a full face shield over safety glasses. Use adequate ventilation for fumes.

CAUTION!

Mechanical hazard – risk of damage to the hot runner. Only use a soft brass or hardwood chisel to remove resin from the hot runner.

6. Remove the resin deposits or dust from the outside of the backup pads and manifold pocket area. If required, carefully heat the resin deposits with a propane torch and then wipe the deposits away with a clean, soft cloth. This may have to be repeated several times.
7. If required, use a brass rod to clean the inside of the backup pads. Do not scratch or score the backup pad surface.
8. Remove the resin deposits or dust from the sealing insert on the backup pad.
9. Check all manifold and nozzle heater wiring using an ohmmeter. Refer to the electrical schematic for specific wire and heater resistances.
10. Install the backup pads or cylinders on the manifold.
 - For information about installing backup pads, refer to [Section 6.10](#)
 - For information about installing cylinders, refer to [Section 6.11](#)
11. If equipped, install the center plate. Refer to [Section 6.8.2](#) for more information.
12. Install the backing plate. Refer to [Section 6.7](#) for more information.
13. Install the hot runner into the machine. Refer to [Section 4.3](#) for more information.

Chapter 7 Storage and Shipping

Hot runner surfaces are sensitive to many environmental conditions and require special methods for storage and shipping to avoid damage.

NOTE:

The storage instructions in [Section 7.2](#) are recommended when shipping the hot runner by air.

NOTE:

The storage instructions in [Section 7.3](#) are recommended when shipping the hot runner overseas.

CAUTION!

Mechanical hazard – risk of damage to the hot runner. Store all hot runners in an air conditioned environment.

7.1 Corrosion Protection

Humidity, salt in the air, rapid weather changes, and even condensation that forms during operation can quickly damage an unprotected hot runner.

Use a protective spray that does not contain chlorofluorocarbons (CFCs), has good moisture and oxidation resistance, and is resistant to mild acids and alkaline.

For additional corrosion protection during storage, add a moisture-absorbing silicate bag before sealing the hot runner in a vacuum polyethylene bag.

**WARNING!**

Poison hazard – risk of death or serious injury. Before using any corrosion protection product, always follow the supplier's recommendations for use and thoroughly review the Material Safety Data Sheet (MSDS).

7.2 Short Term Storage

Short term storage is intended for periods less than three months and can be done either in the machine or separately.

7.2.1 Storing in the Machine

1. Open the clamp to full shutheight.
2. Lock out and tag the machine and controller (if equipped). Refer to [Section 2.5](#) for more information.
3. Clean the mold, hot runner and molding surfaces of dirt, debris and condensation.
4. Perform all required preventive maintenance procedures. Refer to [Section 6.1](#) for more information.
5. Inspect all moving components for damage. Replace or repair as needed.



WARNING!

Poison hazard – risk of death or serious injury. Protective sprays can cause headaches, dizziness, nausea and anesthetic effects. Wear a face shield and solvent resistant gloves. If used in an enclosed area, use an organic vapor respirator or self-contained breathing apparatus.

-
6. Spray all accessible faces and molding surfaces with a protective spray. Allow surfaces to dry for approximately two hours. Refer to [Section 3.5](#) for information about recommended lubricants.

If additional coats are required, make sure the hot runner has thoroughly dried before the next application.

7. Leave the mold open.

7.2.2 Storing Outside the Machine

To store the hot runner separately from the machine for a period of less than three months, do the following:

1. Open the clamp to full shutheight.
2. Lock out and tag the machine and controller (if equipped). Refer to [Section 2.5](#) for more information.
3. Purge all cooling water from the hot runner. Refer to the machine manufacturer's documentation for more information.
4. Clean the mold, hot runner and molding surfaces of dirt, debris and condensation.
5. Perform all required preventive maintenance procedures as required. Refer to [Section 6.1](#) for more information.
6. Inspect all moving components for damage. Replace or repair as needed.



WARNING!

Poison hazard – risk of death or serious injury. Protective sprays can cause headaches, dizziness, nausea and anesthetic effects. Wear a face shield and solvent resistant gloves. If used in an enclosed area, use an organic vapor respirator or self-contained breathing apparatus.

7. Spray all accessible faces and molding surfaces with LPS 2 protective spray. Allow surfaces to dry for approximately two hours. Refer to [Section 3.6](#) for specifications on protective spray.
If additional coats are required, make sure the hot runner has thoroughly dried before the next application.
8. Remove the hot runner from the machine. Refer to [Section 4.3.2](#) for more information
9. Place a cover over the hot runner to protect it during storage.
10. Store the hot runner in an air conditioned environment.

7.3 Long Term Storage

To store the mold and/or hot runner for a period of more than three months, do the following:

NOTE:

The following procedure can also be used to store spare parts.

1. Prepare the mold and/or hot runner for storage and remove it from the machine. Refer to [Section 7.2.2](#) for more information.
2. Place the mold and/or hot runner on a wooden platform.
3. Place the mold and/or hot runner in a 0.1 mm (0.004 in) or heavier (thicker) polyethylene bag along with a suitably sized moisture absorbing silicate bag.
The silicate bag offers additional corrosion protection.
4. Remove the lift bar and hoist ring.
5. Vacuum heat seal the polyethylene bag to retain the protective spray and prevent invasion of dirt or moisture.

7.4 Shipping the Hot Runner

The following guidelines should be followed when shipping a hot runner:

CAUTION!

Mechanical hazard – risk of damage to equipment. Residual coolant could freeze when transporting the hot runner in cold climates. Make sure all coolant is drained fully from the system before transporting it. Failure to do so could cause severe damage to the hot runner.

1. Before shipping the hot runner, check that all coolant has been drained fully.
2. Pack the hot runner, regardless of where it is being shipped, in a shipping crate. This will provide the best possible protection from any damage. For Cross Manifold design, and prior to manifold removal, make sure that the alignment pull dowels that keep the cross and main manifolds aligned during assembly are re-installed.

3. When returning a mold and/or hot runner to Husky for refurbishing, include the following items for testing purposes:
 - All electrical cables and switch boxes
 - All lift bars and latch bars installed in their shipping position on the hot runner
 - All mechanisms that had to be removed from the hot runner for any reason