

INSTALLATION DRAWING

REV 1
8093478

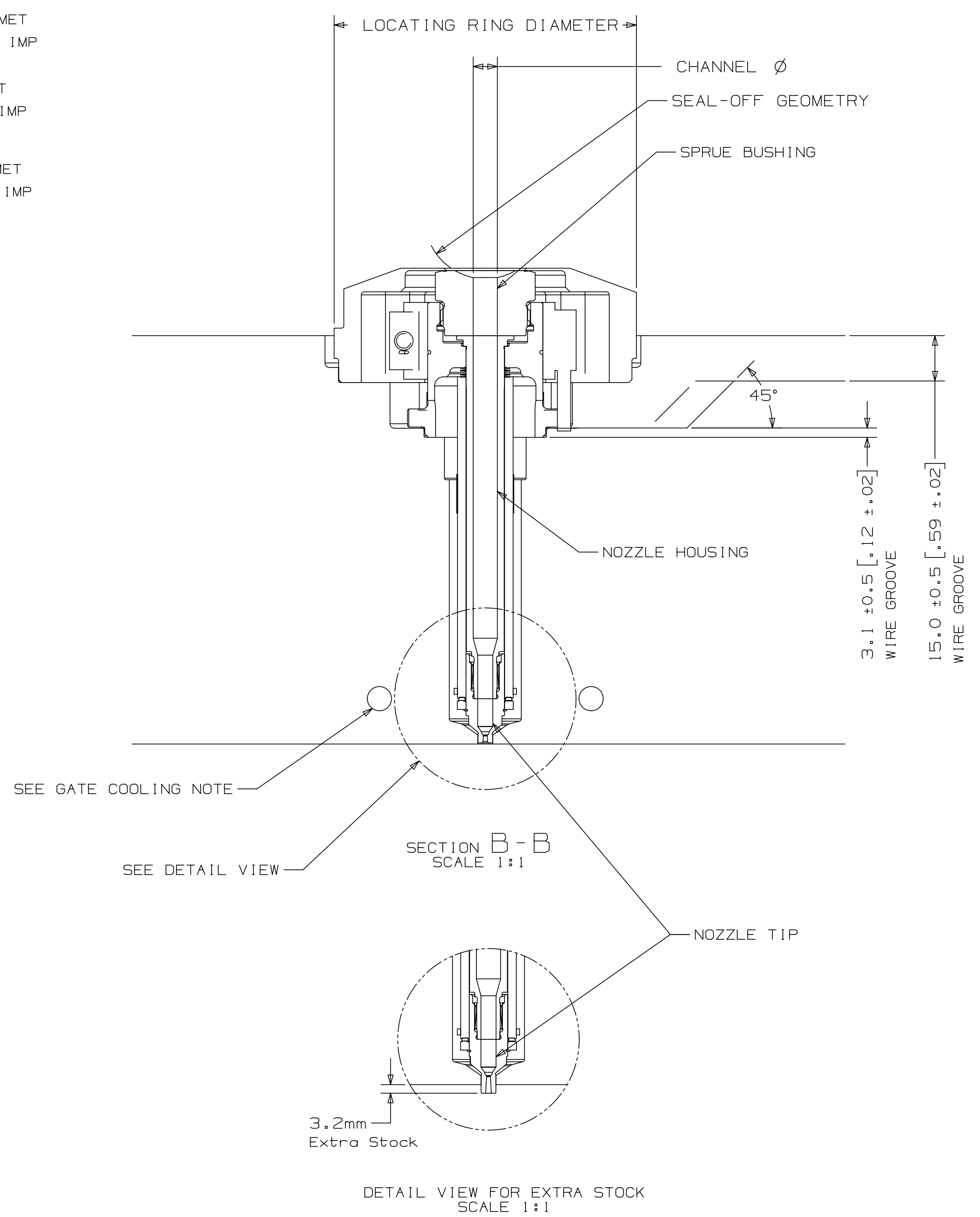
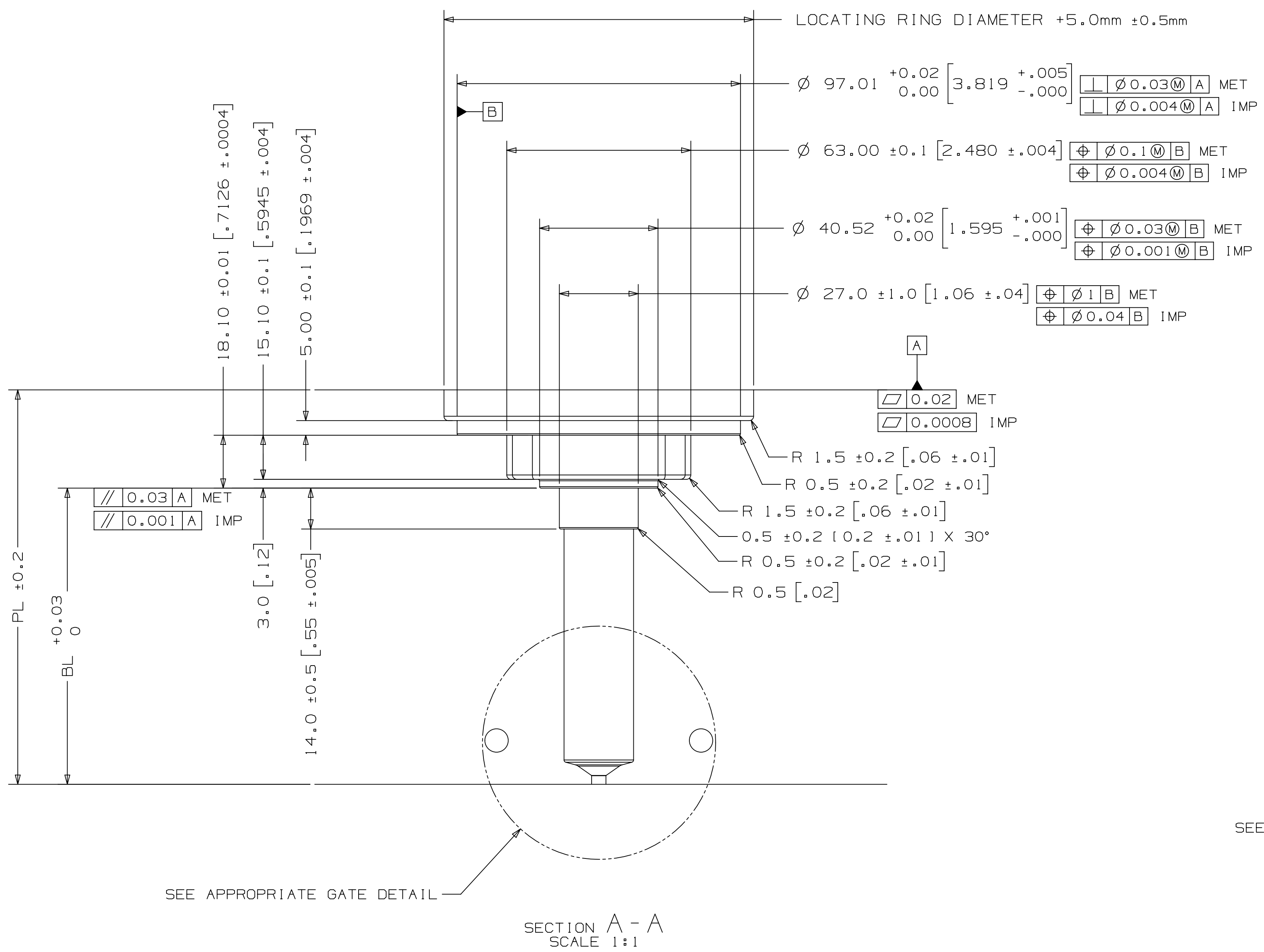
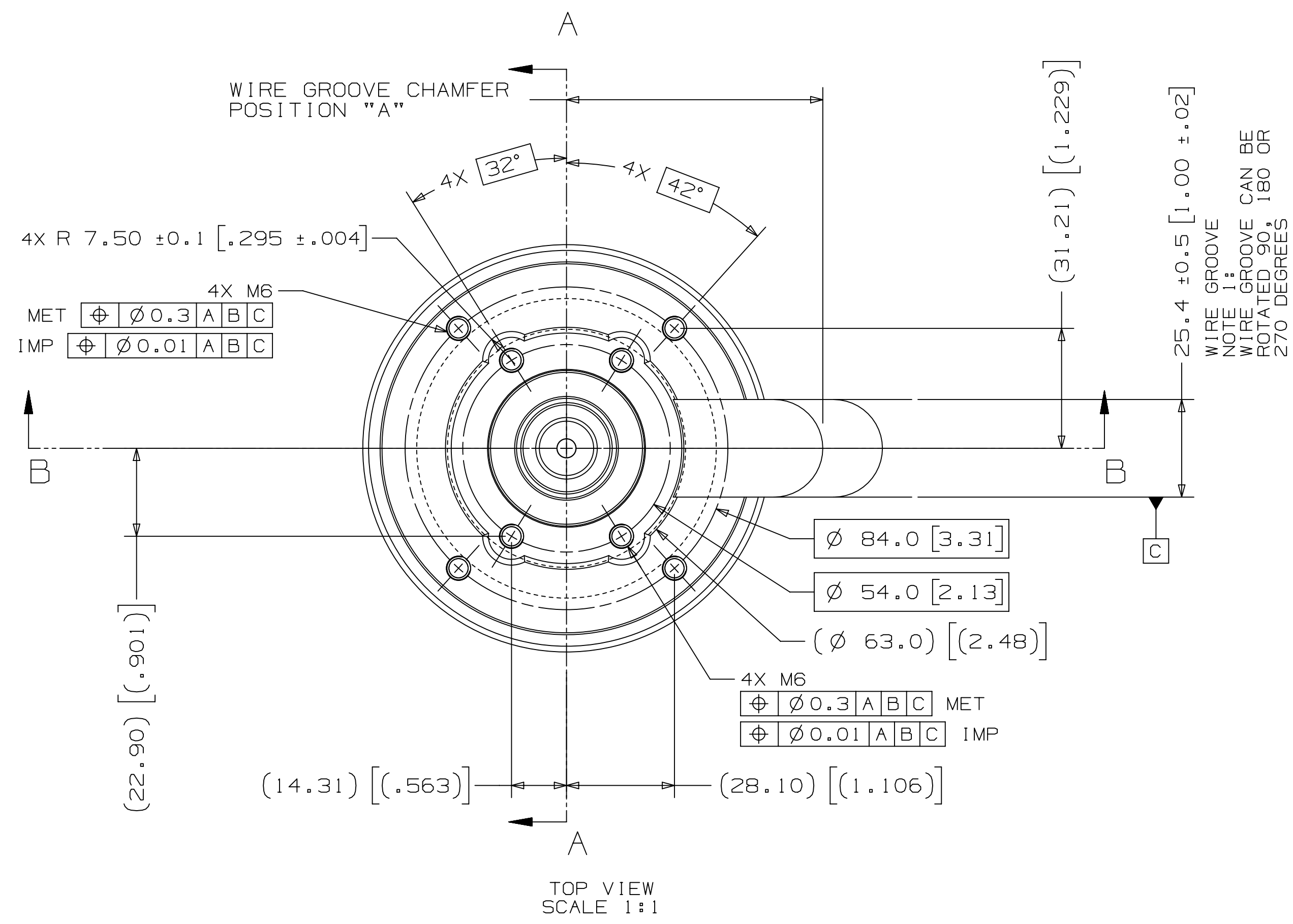

NOZZLE SERIES	NOZZLE TIP	PL RANGE	Approx. BL *
U500	HT-TS	54.28 [2.137] - 221.44 [8.718]	32 [1.26] - 181 [7.13]

* Approx. BL VALUES IN THE TABLE ARE REFERENCES WHICH CAN DEVIATE BY +/-1mm.
FINAL BL VALUE CAN BE FOUND ON GATE DETAIL DRAWING AND 3D AFTER FINISHED DESIGN.
BL AVAILABLE IN THE INCREMENT OF 10mm WITHIN RANGE.

U500	SPRUE BUSHING	
	SEAL-OFF GEOMETRY SPHERICAL RADIUS	CHANNEL Ø IN - OUT
	FLAT	4 - 8
	FLAT	
	SEAL-OFF 12.7 [1/2]	
	SEAL-OFF 15.5	6.35 - 8
	SEAL-OFF 19.05 [3/4]	8 - THRU
	SEAL-OFF 20	
	SEAL-OFF 40	

U500	LOCATING RING DIAMETER	WIRE GROOVE CHAMFER POSITION "A" (±2.0)
	100	66.7
	101.3 [3.99]	66.7
	125	78.7

DIMENSIONS SHOWN AS: millimeters [inches]

RECOMMENDED GATE COOLING GUIDELINES
ADEQUATE COOLING IS ESSENTIAL FOR THE PROPER FUNCTION OF THIS SYSTEM. REFER TO THE HOT RINGER PRODUCT GUIDE www.husky.ca FOR MORE DETAILED GUIDELINES.

RECOMMENDED GATE MATERIAL
NOTE: THESE MATERIALS MAY NOT OFFER THE DESIRED RESISTANCE TO ABRASIVE AND/OR CORROSIVE RESINS, FILLERS AND/OR ADDITIVES
AISI H13 (48-51 Rc)
AISI 420 (48-51 Rc)

RECOMMENDED GATE MANUFACTURING GUIDELINES

- HARDENED GATE INSERTS 148-511 ARE RECOMMENDED WHEN USING SOFTER CAVITY STEELS. SOFTER CAVITIES MAY BE ACCEPTABLE FOR CERTAIN APPLICATIONS. CONTACT YOUR HUSKY REPRESENTATIVE WITH QUESTIONS.
- EDM'ING THE GATE AREA CAUSES MICRO CRACKS WHICH LEAD TO BRITTLE GATE FAILURES. ALSO - DO NOT EDM THE MOLDING SURFACE WITHIN 2mm OF THE GATE HOLE.
- MACHINE THE GATE HOLE AFTER HARDENING TO AVOID EXCESSIVE QUENCH IN THE THIN SECTION DURING HEAT TREAT & RESULTING OVERHARDENING IN THE GATE AREA.
- RECESSED GATES ON THE PRODUCT REDUCE THE GATE AREA STRENGTH LEADING TO GATE FAILURES.
- WELDING THE GATE AREA INCREASES STRESSES AT THE GATE. SOFTENING THE AREA AROUND THE WELD AND CAN CAUSE GATE FAILURES.

<p>COAT PER ASME Y14.3M-1994 AND ASME Y14.3M-1994</p> <p>UNLESS OTHERWISE SPECIFIED</p> <p>CD MODEL TO BE USED</p> <p>NEW TOLERANCES OR DIMENSIONS ARE BASIC</p> <p>GENERAL TOLERANCES: METRIC M2.0 IMPERIAL 0.005</p> <p>BROKEN EDGES/CHAMFERS: 1: 1.0 x 45° 0.04 ±0.01 x 45°</p> <p>FILLET/RADIUS: R0.8 ±0.2 R0.03 ±0.01</p> <p>SURFACE FINISH: $\sqrt{3.2}$</p>	<p>FOR TORQUE SPECIFICATIONS, REFER TO HS 252</p> <p>WEIGHT: - kg</p>	<p>HUSKY</p> <p>TITLE: HOT SPRUE</p> <p>SCALE: NONE</p> <p>SHEET: 1 OF 2</p> <p>DATE: AOR</p> <p>REV: 1</p>
---	---	--

ASSEMBLY DRAWING

REV 1
DRAWING 8093478

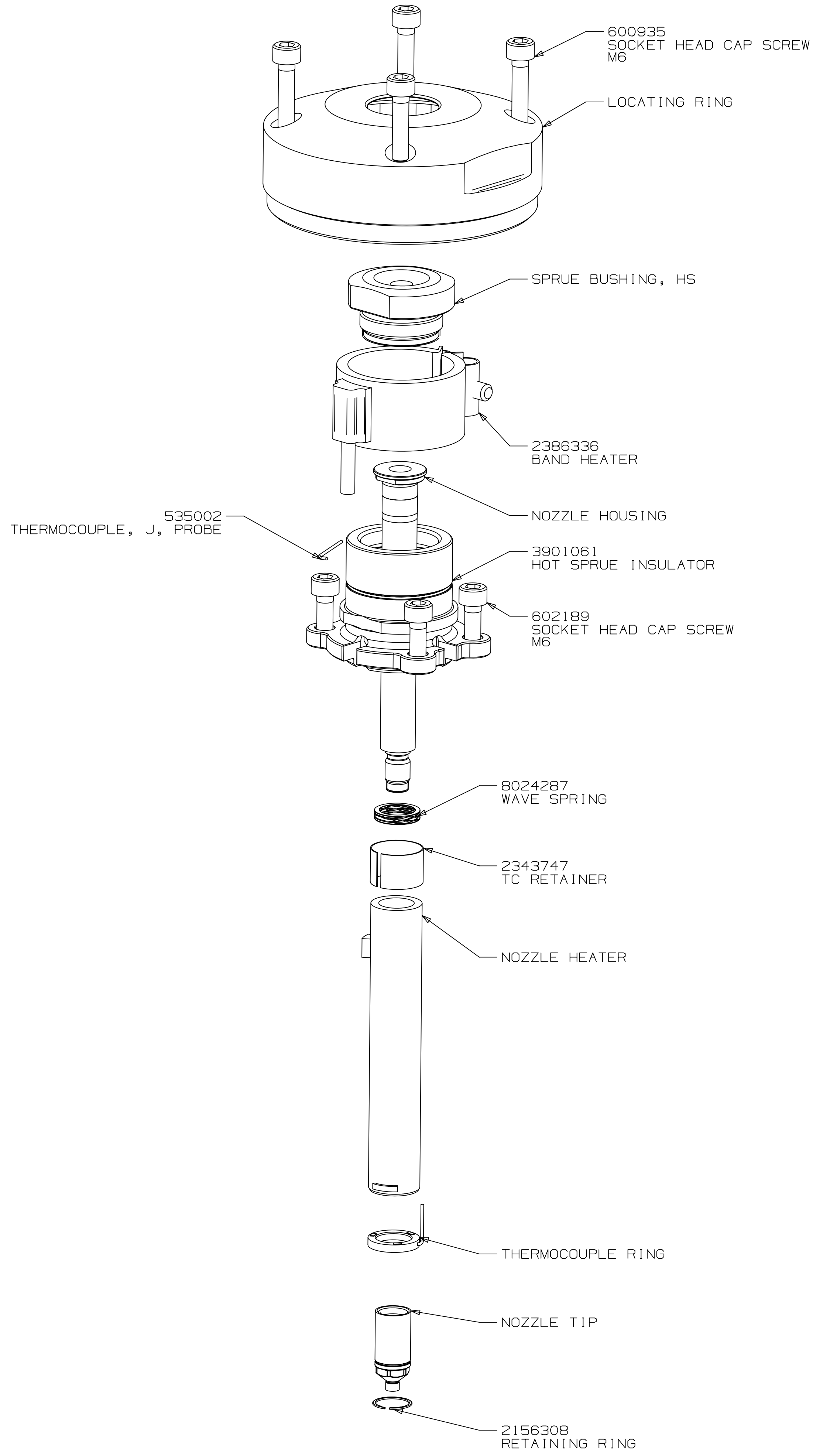

EXPLODED VIEW
SCALE 1:1

UNLESS OTHERWISE SPECIFIED
TORQUE TO HUSKY SPECIFICATION
HS 252

PRELOAD CLASS HGT-80

SIZE	Nm	lb-ft
#8	5	4
#10	7	5
1/4	16	12
5/16	35	25
3/8	60	45
7/16	95	70
1/2	150	110
5/8	290	210
3/4	500	360
7/8	790	580
1	1180	865
M4	4.8	3.4
M5	9.5	7.1
M6	16	12
M8	39	29
M10	77	57
M12	135	100
M14	215	160
M16	330	245
M20	650	480
M24	1100	810

ELECTRICAL INFO (240 VAC)

ZONE	ZONE DESCRIPTION
1	SPRUE BODY
2	NOZZLE TIP

T/C LEADS:
WHITE = (+)
RED = (-)

RECOMMENDED GATE COOLING GUIDELINES
ADEQUATE COOLING IS ESSENTIAL FOR THE PROPER FUNCTION OF THIS SYSTEM. REFER TO THE HOT RUNNER PRODUCT GUIDE FOR MORE DETAILED GUIDELINES.
www.husky.ca

RECOMMENDED GATE MATERIAL
NOTE: THESE MATERIALS MAY NOT OFFER THE DESIRED RESISTANCE TO ABRASIVE AND/OR CORROSIVE RESINS, FILLERS AND/OR ADDITIVES
AISI H13 (49-51 Rc)
AISI 420 (49-51 Rc)

RECOMMENDED GATE MANUFACTURING GUIDELINES

- HARDENED GATE INSERTS (49-51) ARE RECOMMENDED WHEN USING SOFTER CAVITY STEELS. SOFTER CAVITIES MAY BE ACCEPTABLE FOR CERTAIN APPLICATIONS. CONTACT YOUR HUSKY REPRESENTATIVE WITH QUESTIONS.
- EDM'ING THE GATE AREA CAUSES MICRO CRACKS WHICH LEAD TO BRITTLE GATE FAILURES. ALSO - DO NOT EDM THE MOLDING SURFACE WITHIN 2mm OF THE GATE HOLE.
- MACHINE THE GATE HOLE AFTER HARDENING TO AVOID EXCESSIVE QUENCH IN THE THIN SECTION DURING HEAT TREAT & RESULTING OVERHARDENING IN THE GATE AREA.
- RECESSED GATES ON THE PRODUCT REDUCE THE GATE AREA STRENGTH LEADING TO GATE FAILURES.
- WELDING THE GATE AREA INCREASES STRESSES AT THE GATE, SOFTENS THE AREA AROUND THE WELD AND CAN CAUSE GATE FAILURES.

FOR TORQUE SPECIFICATIONS, REFER TO HS 252		TITLE		REV					
		HOT SPRUE U500-HT-TS							
WEIGHT	- kg	SCALE	NONE	SIZE	AIR	DRAWING	8093478	REV	1
		SHEET 2 OF 2							