

INSTALLATION DRAWING

REV 3
8150644

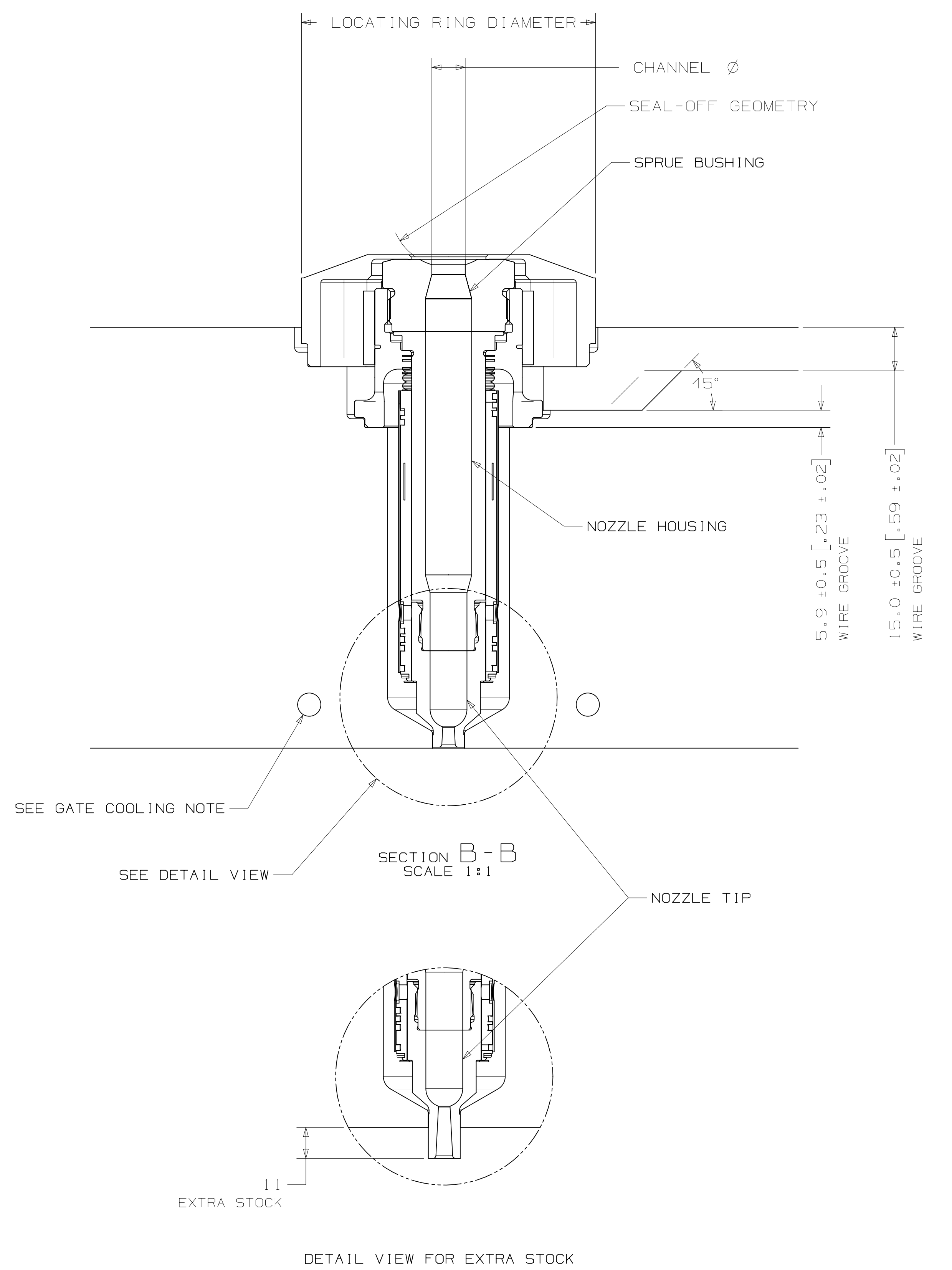
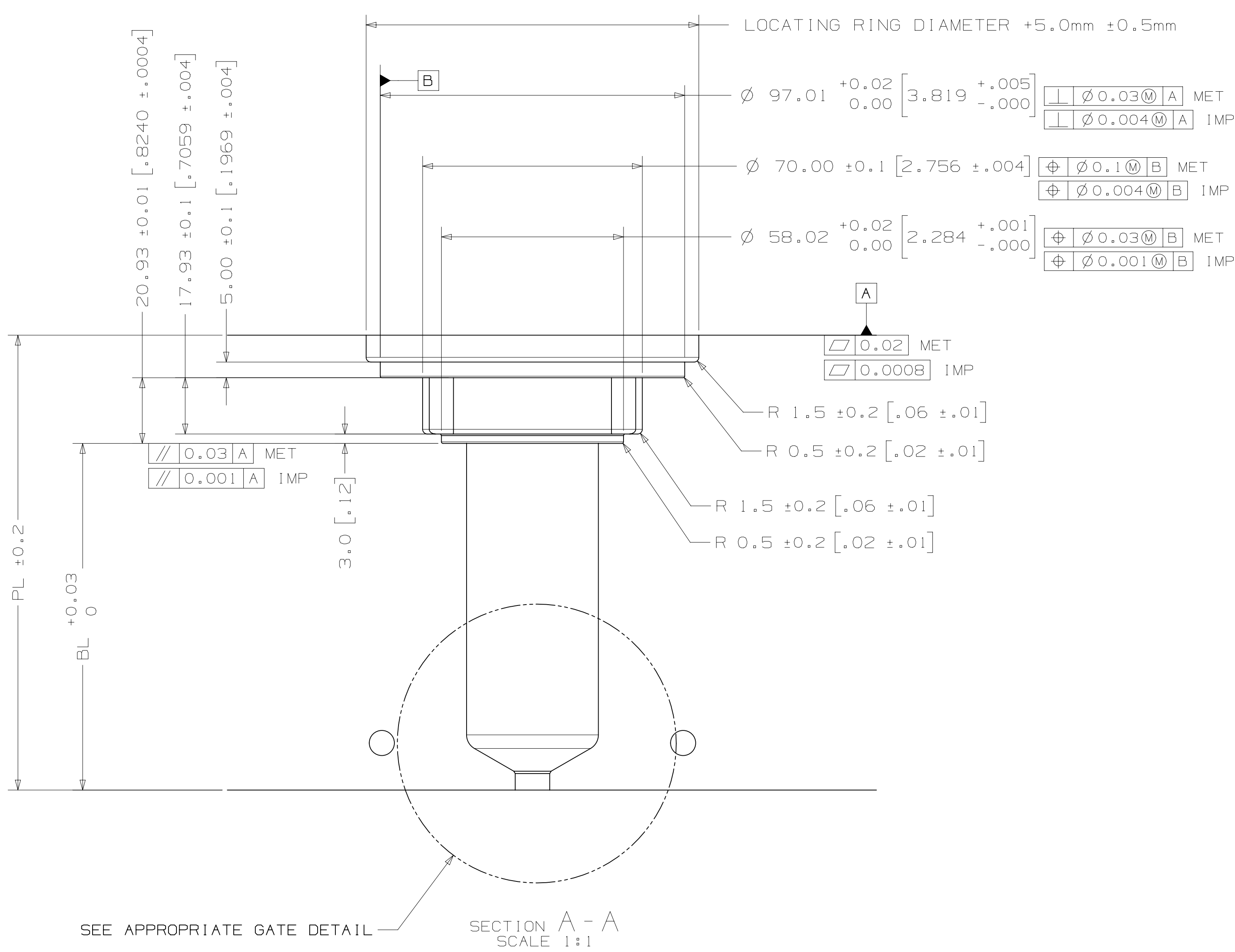
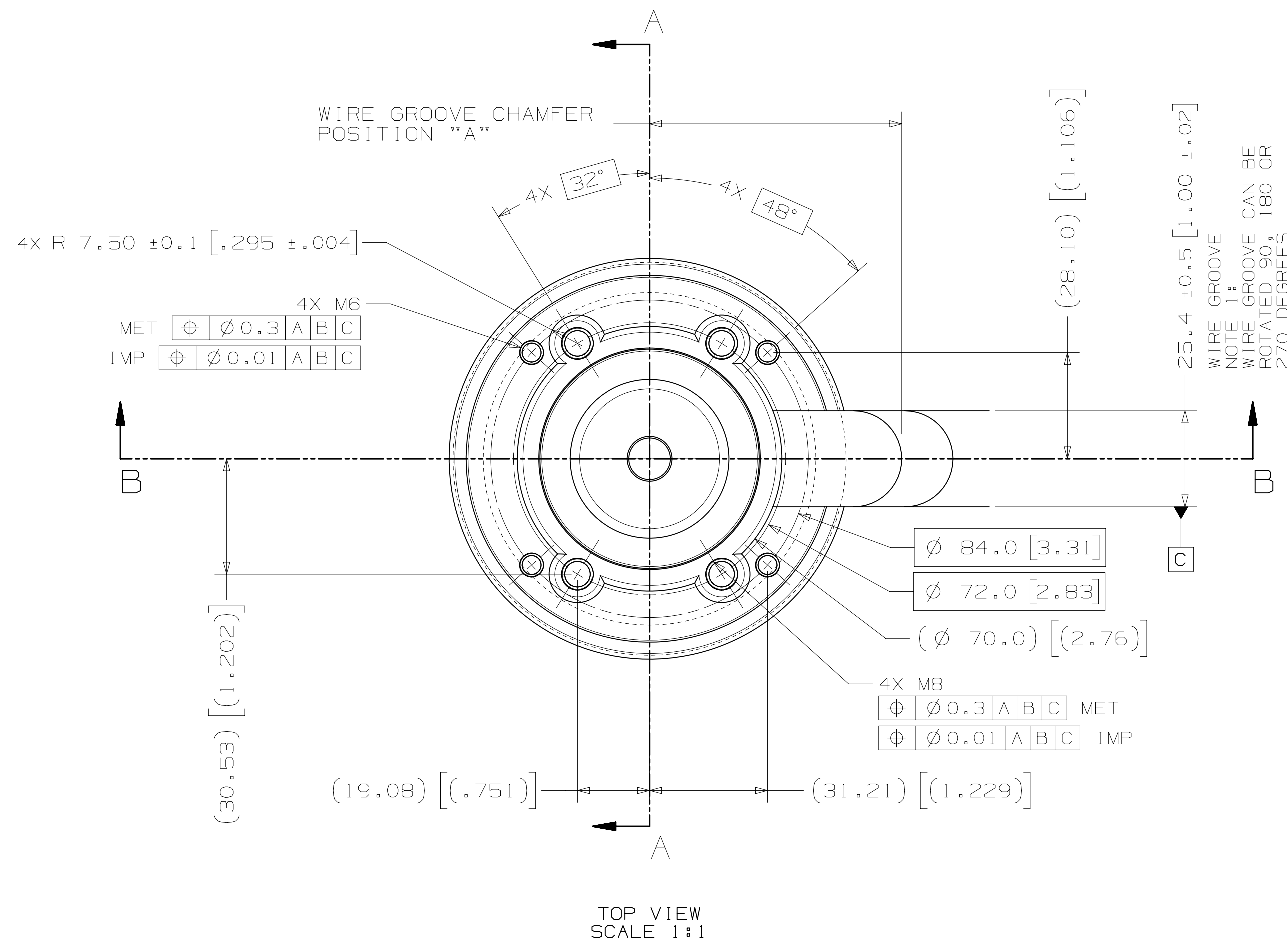

NOZZLE SERIES	NOZZLE TIP	PL RANGE	Approx. BL*
U1000	HT-TS	96.3 [3.791] - 233.4 [9.189]	71 [2.80] - 190 [7.48]

*Approx. BL VALUES IN THE TABLE ARE REFERENCES WHICH CAN DEVIATE BY +/-1mm. FINAL BL VALUE CAN BE FOUND ON GATE DETAIL DRAWING AND 3D AFTER FINISHED DESIGN. BL AVAILABLE IN THE INCREMENT OF 10mm WITHIN RANGE.

U1000	SPRUE BUSHING	
	SEAL-OFF GEOMETRY	CHANNEL IN - OUT
	FLAT	6.35 - 16
	FLAT	
	SEAL-OFF 12.7 [1/2]	11.5 - 16.00
	SEAL-OFF 15.5	
SEAL-OFF 19.05 [3/4]		
SEAL-OFF 20		
	SEAL-OFF 40	

U1000	LOCATING RING DIAMETER	WIRE GROOVE CHAMFER POSITION "A" (±2.0)
	100	66.7
	101.3 [3.99]	66.7
	125	78.7

DIMENSIONS SHOWN AS: millimeters [inches]

RECOMMENDED GATE COOLING GUIDELINES
ADEQUATE COOLING IS ESSENTIAL FOR THE PROPER FUNCTION OF THIS SYSTEM. REFER TO THE HOT RUNNER PRODUCT GUIDE FOR MORE DETAILED GUIDELINES.
www.husky.ca

RECOMMENDED GATE MATERIAL
NOTE: THESE MATERIALS MAY NOT OFFER THE DESIRED RESISTANCE TO ABRASIVE AND/OR CORROSIVE RESINS, FILLERS AND/OR ADDITIVES
AISI H13 (48-51 Rc)
AISI 420 (48-51 Rc)

RECOMMENDED GATE MANUFACTURING GUIDELINES

- HARDENED GATE INSERTS 148-511 ARE RECOMMENDED WHEN USING SOFTER CAVITY STEELS. SOFTER CAVITIES MAY BE ACCEPTABLE FOR CERTAIN APPLICATIONS. CONTACT YOUR HUSKY REPRESENTATIVE WITH QUESTIONS.
- EDM'ING THE GATE AREA CAUSES MICRO CRACKS WHICH LEAD TO BRITTLE GATE FAILURES. ALSO - DO NOT EDM THE MOLDING SURFACE WITHIN 2mm OF THE GATE HOLE.
- MACHINE THE GATE HOLE AFTER HARDENING TO AVOID EXCESSIVE QUENCH IN THE THIN SECTION DURING HEAT TREAT & RESULTING OVERHARDENING IN THE GATE AREA.
- RECESSED GATES ON THE PRODUCT REDUCE THE GATE AREA STRENGTH LEADING TO GATE FAILURES.
- WELDING THE GATE AREA INCREASES STRESSES AT THE GATE, SOFTENS THE AREA AROUND THE WELD AND CAN CAUSE GATE FAILURES.

FOR TORQUE SPECIFICATIONS, REFER TO HS 252

WEIGHT - kg

HUSKY
TITLE: HOT SPRUE
U1000-HT-TS
SCALE: NONE
SIZE: AOR
DRAWING: 8150644
REV: 3

ASSEMBLY DRAWING

REV 3
DRAWING 8150644

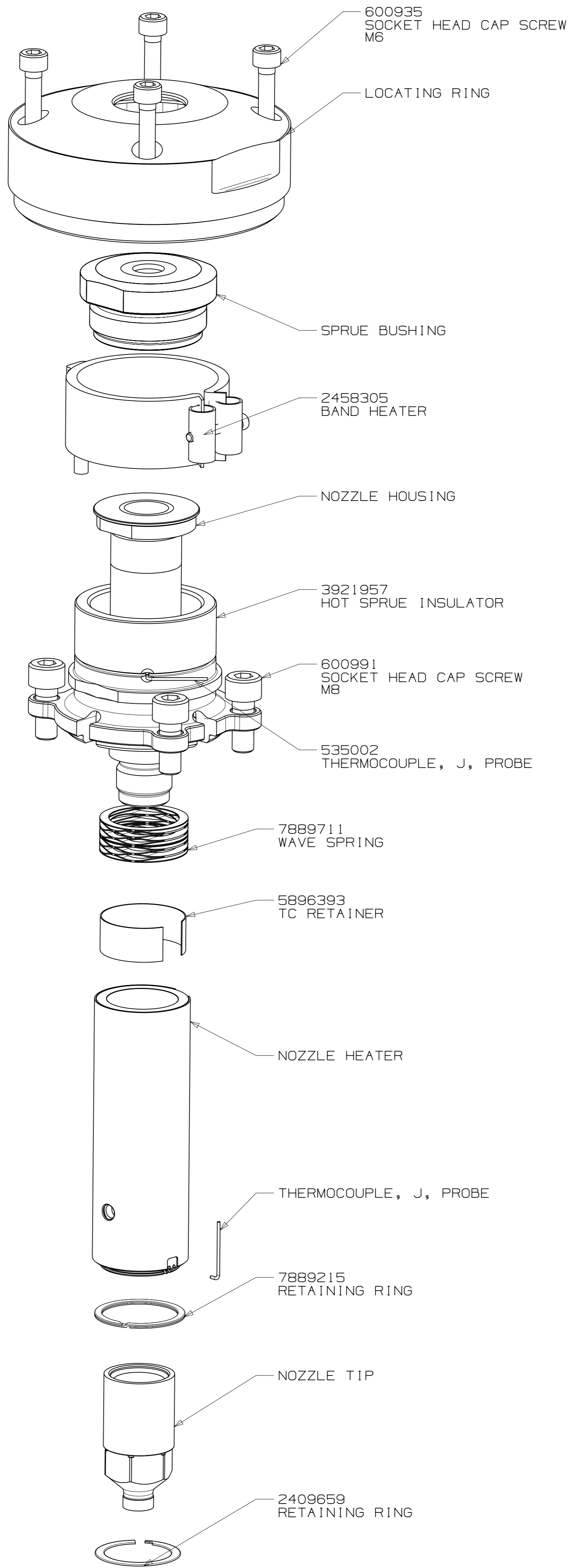

EXPLODED VIEW
SCALE 1:1

UNLESS OTHERWISE SPECIFIED
TORQUE TO HUSKY SPECIFICATION
HS 252

PRELOAD CLASS HGT-80

SIZE	Nm	lb-ft
#8	5	4
#10	7	5
1/4	16	12
5/16	35	25
3/8	60	45
7/16	95	70
1/2	150	110
5/8	290	210
3/4	500	360
7/8	790	580
1	1180	865
M4	4.6	3.4
M5	9.5	7.1
M6	16	12
M8	39	29
M10	77	57
M12	135	100
M14	215	160
M16	330	245
M20	650	480
M24	1100	810

ELECTRICAL INFO (240 VAC)	
ZONE	ZONE DESCRIPTION
1	SPRUE BODY
2	NOZZLE TIP
T/C LEADS: WHITE = (+) RED = (-)	
RECOMMENDED GATE COOLING GUIDELINES ADEQUATE COOLING IS ESSENTIAL FOR THE PROPER FUNCTION OF THIS SYSTEM. REFER TO THE HOT RUNNER PRODUCT GUIDE FOR MORE DETAILED GUIDELINES. www.husky.ca	
RECOMMENDED GATE MATERIAL NOTE: THESE MATERIALS MAY NOT OFFER THE DESIRED RESISTANCE TO ABRASIVE AND/OR CORROSIVE RESINS, FILLERS AND/OR ADDITIVES AISI H13 (49-51 Rc) AISI 420 (49-51 Rc)	
RECOMMENDED GATE MANUFACTURING GUIDELINES - HARDENED GATE INSERTS (49-51) ARE RECOMMENDED WHEN USING SOFTER CAVITY STEELS. SOFTER CAVITIES MAY BE ACCEPTABLE FOR CERTAIN APPLICATIONS. CONTACT YOUR HUSKY REPRESENTATIVE WITH QUESTIONS. - EDM'ING THE GATE AREA CAUSES MICRO CRACKS WHICH LEAD TO BRITTLE GATE FAILURES. ALSO - DO NOT EDM THE MOLDING SURFACE WITHIN 2mm OF THE GATE HOLE. - MACHINE THE GATE HOLE AFTER HARDENING TO AVOID EXCESSIVE QUENCH IN THE THIN SECTION DURING HEAT TREAT & RESULTING OVERHARDENING IN THE GATE AREA. - RECESSED GATES ON THE PRODUCT REDUCE THE GATE AREA STRENGTH LEADING TO GATE FAILURES. - WELDING THE GATE AREA INCREASES STRESSES AT THE GATE, SOFTENS THE AREA AROUND THE WELD AND CAN CAUSE GATE FAILURES.	

FOR TORQUE SPECIFICATIONS, REFER TO HS 252	METRIC	HUSKY							
		TITLE HOT SPRUE U1000-HT-TS							
WEIGHT	- kg	SCALE	NONE	SIZE	AIR	DRAWING	8150644	REV	3
		SHEET 2 OF 2							