

CHANGES TO RESIN INFORMATION AND PART SIZE CAN RESULT IN GATE SIZE CHANGES

DRAWING 6548525 REV 0

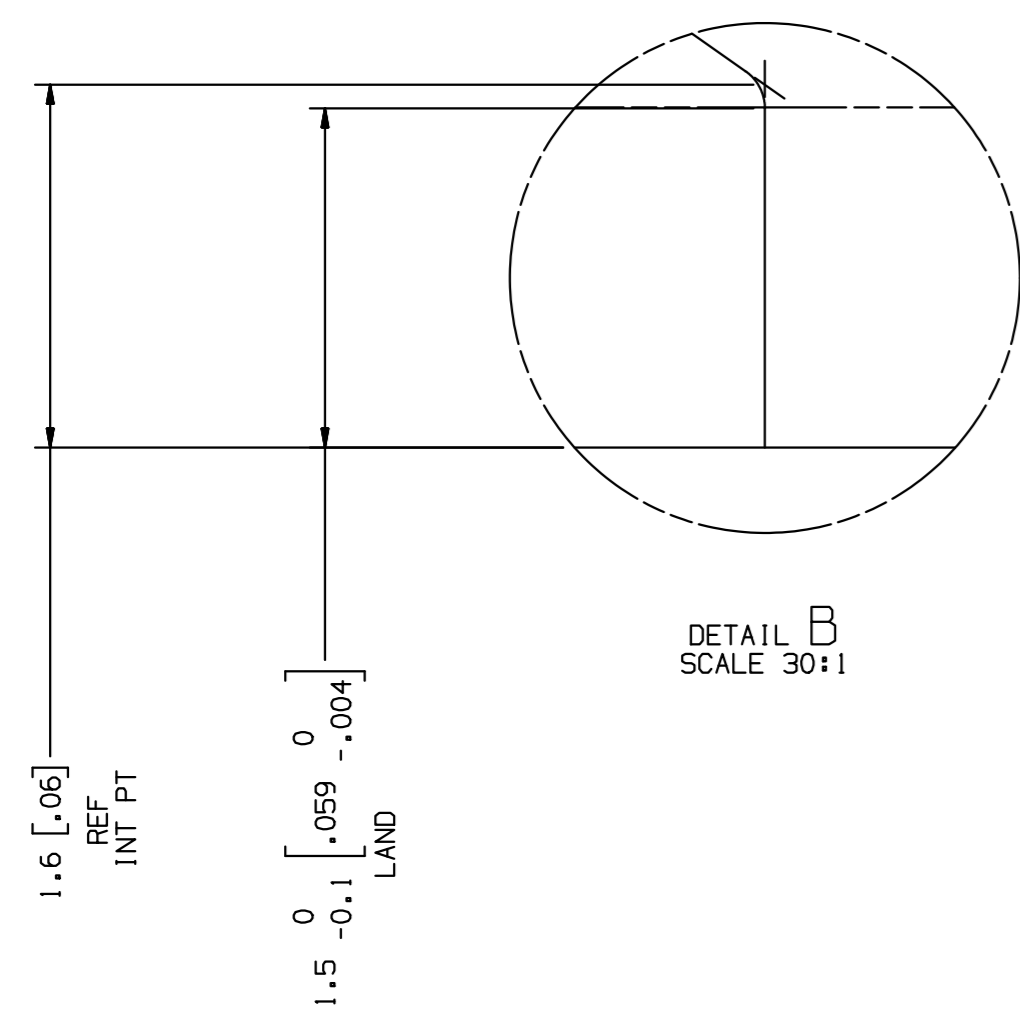
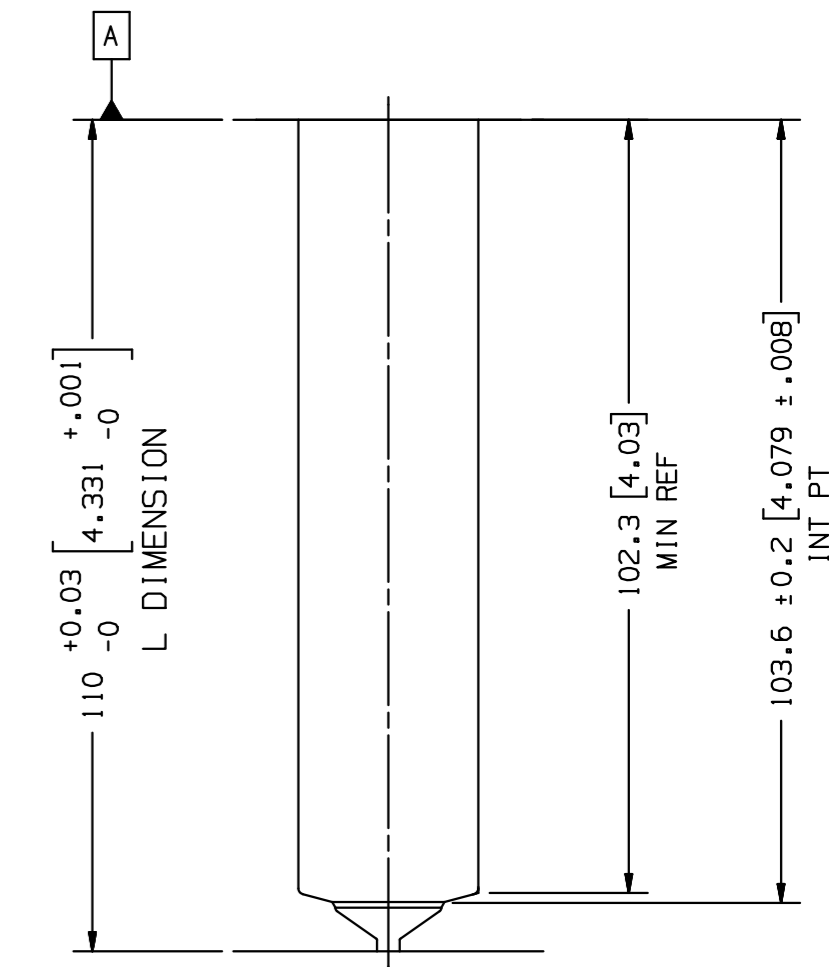
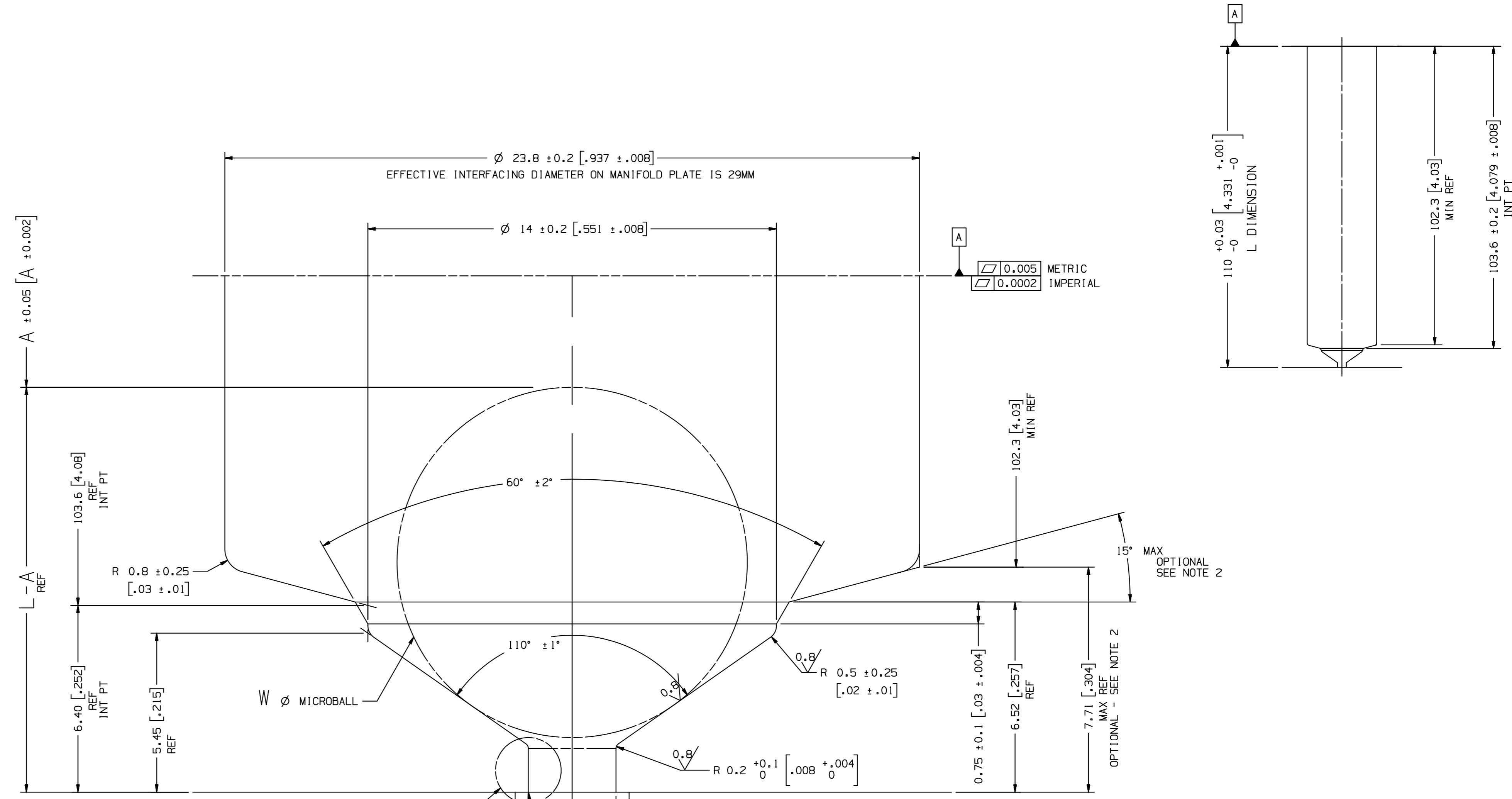
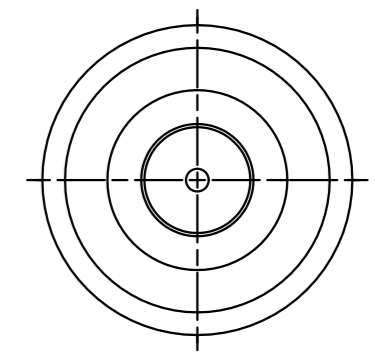

MICROBALL INSPECTION DIMENSIONS
MICROBALL DIMENSIONS ARE PROVIDED FOR REFERENCE ONLY AND ARE NOT INTENDED TO DEFINE OR LIMIT INSPECTION METHODOLOGY

NOTES:
1. METRIC/INCH CONVERSIONS ARE NOT DIRECT TRANSLATIONS. DIFFERENT MICROBALLS ARE USED.
2. 15° TAPER FEATURE IS OPTIONAL AND INTENDED TO EASE MANUFACTURING. IT IS NOT REQUIRED FOR GATE DETAIL FUNCTIONALITY.

RECOMMENDED GATE COOLING GUIDELINES

ADEQUATE GATE COOLING IS ESSENTIAL FOR ACHIEVING GOOD GATE QUALITY. REFER TO THE HUSKY GATE COOLING GUIDELINES WITHIN THE HOT RUNNER PRODUCT GUIDE ON www.husky.ca/hotrunnertools

RECOMMENDED GATE MATERIAL

NOTE: THESE MATERIALS MAY NOT OFFER THE DESIRED RESISTANCE TO ABRASIVE AND/OR CORROSIVE RESINS, FILLERS AND/OR ADDITIVES:
AISI H13 (49-51 Rc)
AISI 420 (49-51 Rc)
* P20 (PRE-HARDENED 29-36 Rc)
* BeCu B25 (PRE-HARDENED 36-41 Rc)
* = NOT RECOMMENDED FOR VALVE GATES.

RECOMMENDED GATE MANUFACTURING GUIDELINES

- HARDENED GATE INSERTS (49-51) ARE RECOMMENDED WHEN USING SOFTER CAVITY STEELS. SOFTER CAVITIES MAY BE ACCEPTABLE FOR CERTAIN APPLICATIONS. CONTACT YOUR HUSKY REPRESENTATIVE WITH QUESTIONS.
- ANY KIND OF MANUFACTURING OR REWORK METHOD SHOULD NOT LEAD TO EMBRITTLEMENT OF THE GATE AREA AND MOLDING SURFACE WITHIN 2mm OF THE GATE HOLE.
- MACHINE THE GATE HOLE AFTER HARDENING TO AVOID EXCESSIVE QUENCH IN THE THIN SECTION DURING HEAT TREAT & RESULTING OVERHARDENING IN THE GATE AREA.
- RECESSED GATES ON THE PRODUCT REDUCE THE GATE AREA STRENGTH LEADING TO GATE FAILURES.
- WELDING THE GATE AREA INCREASES STRESSES AT THE GATE, SOFTENS THE AREA AROUND THE WELD AND CAN CAUSE GATE FAILURES.

INCH DESIGN & INSPECTION CHART

MICROBALL SIZE	DIMENSION	ACTUAL
W = 1/2"	A = 3.754"	
	L-A = 0.577"	

METRIC DESIGN & INSPECTION CHART

MICROBALL SIZE	DIMENSION	ACTUAL
W = 12.00 mm	A = 96.13 mm	
	L-A = 13.87 mm	

DIMENSIONS IN BRACKETS () ARE INCH

HUSKY PROJECT	CUSTOMER: xx PART NAME: xx PART NUMBER: xx PRODUCT: xx DROPS: xx NOZZLE SIZE: xx TIP STYLE: xx
CUSTOMER MOLD	xx
MATERIAL	
FINISH/TREATMENT	
WEIGHT	- kg

HUSKY

TITLE: GATE DETAIL
ULTRA 500
NEW VG - V2
1.0mm GATE

SCALE 1:1 SIZE A1 DRAWING 6548525 REV 0 SHEET 1 OF 1

REV	DATE	DESCRIPTION	NAME

ORIGINAL ISSUE - DESIGNED BY: